

Model 876EC Intelligent Transmitter for Electrodeless Conductivity Measurements with HART® Communication Protocol



The Foxboro® Model 876EC is a 2-wire loop powered intelligent transmitter that, when used with appropriate electrochemical sensors, provides measurement, local display, and transmission of electrodeless conductivity. The transmitter outputs a HART digital signal and a 4 to 20 mA analog output.

FEATURES

- ▶ 4 to 20 mA output with a HART⁽¹⁾ digital signal.
- ▶ Temperature prediction⁽²⁾
- ▶ Remote configuration/calibration with the HART Communicator or PC-based Configurator.
- ▶ Local configuration with the keypad on the integral local human interface.
- ▶ LCD indicator can display either one, two, or three measurement variables.
- ▶ Fault isolation to transmitter or sensor.
- ▶ Continuous transmitter/sensor diagnostics.
- ▶ Temperature compensation and concentration curves.
- ▶ Agency approved/certified as intrinsically safe device for use in hazardous area locations.
- ▶ FDT certified DTM (Device Type Manager).
- ▶ Wide measurement range.
- ▶ Two levels of passcode protection provided.
- ▶ Compatible with Foxboro 871EC, 871FT, EP307B, EP307G, and FT10 Series electrodeless conductivity sensors.
- ▶ Complies with applicable NAMUR standards, and EMC directive 2014/30/EU.
- ▶ Enclosure meets IP66 and NEMA 4X ratings.
- ▶ Output Hold.

1. Usable with HART Versions 5, 6, and 7.

2. Patent pending

Equipment should be installed, operated, serviced, and maintained only by qualified personnel. No responsibility is assumed by Schneider Electric for any consequences arising from the use of this material.

CONDUCTIVITY AND CONCENTRATION MEASUREMENT

This transmitter can be configured to measure in conductivity units ($\mu\text{S}/\text{m}$, $\mu\text{S}/\text{cm}$, mS/m , mS/cm , or S/m), or one of a host of chemical concentration units such as percent (%) by weight, grams per liter (g/L), parts per million (ppm), and parts per thousand (ppt). A series of preprogrammed temperature and percent chemical concentration curves are available as a standard feature. User programmable curves may also be used for special applications such as uncommon chemicals, proprietary processes, or nonbinary solutions.

INTRINSICALLY SAFE DESIGN

The 876EC Transmitter is designed for compliance with FM, CSA, ATEX, and IECEx standards for intrinsically safe and nonincendive apparatus in hazardous area locations. Refer to "ELECTRICAL SAFETY SPECIFICATIONS" on page 21.

TEMPERATURE PREDICTION

For a Foxboro sensor, a proprietary mathematical algorithm is applied to accelerate the sensor's response to changes in the process temperature. This reduces inaccuracies that may appear in the compensated measurements when the process temperature changes rapidly.

MEASUREMENT INTEGRATION

This transmitter provides efficient integration of measurements into HART process control schemes. It operates by using a bidirectional digital signal superimposed on the 4 to 20mA analog output.

Remote communication of digital values plus status and configuration information can be achieved via HART communication protocol.

Configurations used with this HART version are:

- ▶ The HART Communicator (users having HART Communicator for other devices can have them upgraded with Device Descriptors (DDs) to accommodate this transmitter).
- ▶ The local human interface.
- ▶ A PC-based configurator (FDT).
- ▶ A Distributed Control System (DCS).

With HART, digital multidropping is permitted. This is the connection of several transmitters to a single communications line. Multiple transmitters can be connected on a single twisted pair of wires. See Figure 8.

CUSTOMIZE AND EMPLOY UP TO THREE APPLICATIONS

This unique feature allows you to preconfigure the transmitter for up to three different applications. Each application may have its own display format, temperature compensation curve, chemical concentration curve (if applicable), and output configuration. Each application is assigned a number, for example, "Application 1," "Application 2," or "Application 3." If you wish to move from one application to another, you can simply change one parameter in the configuration menu and the entire application set switches in automatically. This is a powerful feature for users who frequently change between a handful of common, or even custom, recipes.

AUTO-SWITCHING

A useful extension to the multi application feature is an auto-switching capability between either two or three applications. User-programmable switch limits determine when the transmitter auto-switches from Application 1 to Application 2, then again from Application 2 to Application 3. Similarly, the transmitter auto-switches in descending fashion depending on the program set by the user. Because each of the applications (up to three) is individually configured, calibration constants are stored in memory and invoked as the application is retrieved.

Thus the transmitter can change from a wide range conductivity application to a very sensitive one (e.g., Rinse, Product, and CIP) without the need to recalibrate the system for the new range. This results in tremendous time savings for operators, and helps eliminate common sources of inaccuracy in critical applications.

HIGH SENSITIVITY, WIDE RANGE

Highly accurate measurements are provided by the combination of the 876EC Transmitter and patented 871EC Sensors. Refer to Table 1, Table 2, and Table 3, for a listing of the wide variety of conductivity ranges available. The transmitter delivers a high sensitivity conductivity system for applications such as steam condensate or boiler blowdown. Measurement display formats as low as 9.999 $\mu\text{S}/\text{cm}$ can be accommodated. However, the analyzer is also capable of measuring as high as 2000 mS/cm with numerous intermediate measurement display choices, resulting in better compatibility with more applications.

SAVE AND RESTORE CONFIGURATIONS

Configuring an electrochemical transmitter involves the setting of many parameters specific for the application. For example, measurement, sensor configuration, temperature compensation, output, chemical composition, and damping are just a few of the parameters that can be configured. In some cases, you may wish to employ the transmitter for more than one application (at different times). Rather than having to change several parameters, the Model 876EC allows you to save up to two unique configuration profiles, even when they contain multiple applications. Each profile can have up to three applications. Either of these two profiles can be restored at any time to facilitate a quick and easy change of the transmitter to a pre-saved configuration. In addition to the two user profiles, the transmitter also includes a “factory default” configuration which allows you to return the transmitter to its original factory configuration at any time.

QUICK AND INFORMATIVE STATUS

Using the status key, you can access the information necessary to assess the performance of the measurement loop. Among the parameters this “read only” key accesses are:

- ▶ Solution Temperature
- ▶ Absolute Measurement
- ▶ Compensated Measurement
- ▶ Chemical Concentration
- ▶ Measurement Status
- ▶ Date of Last Calibration

SENSOR AND TRANSMITTER DIAGNOSTICS

These functions include View Faults, Suspend Faults, Resume Faults, and View History. Typical faults include:

- ▶ Measurement Overrange and Underrange
- ▶ Compensation Overrange and Underrange
- ▶ Analog Output Overrange and Underrange
- ▶ Calibration Required
- ▶ Liquid Leakage into Sensor Body
- ▶ ATC Short and ATC Open

The user can enable or disable any of the listed faults. Fault status is displayed in the main Diagnostic Menu. If there are no faults, then “No Active Faults” will be displayed. The user can suspend active faults from the measurement status for one hour, and can resume faults at any time.

HISTORY LOGS

The history log can be viewed and cleared by the user, and can be viewed using any of four filters: an error selection, an operational selection, a calibration selection, and an all history selection. The history log includes all faults, power restore, entries and exits from configuration, calibration, and Hold, and faults that have been temporarily suspended.

EASE OF SENSOR CONFIGURATION

The Foxboro brand is the world leader in electrodeless conductivity sensor technology and product breadth. It offers both insertion/submersion sensors, the 871EC Series; and revolutionary flow-through sensors, the 871FT and the FT10 Series. These sensors are offered in a multitude of sizes, materials, geometries, and mounting configurations to satisfy the majority of applications in process industries. Different sensor form factors and construction techniques result in different sensor cell factors, which affect the sensitivity and range of a particular conductivity loop.

To simplify the sensor compatibility process, the analyzer provides menu selections for each type of 871EC, 871FT, and FT10 sensor, as well as custom cell factors for optimization of special sensors. In addition, a selection of three different temperature compensator inputs (100 ohm platinum RTD, 1000 ohm platinum RTD, and 100 k ohm thermistor)

facilitates compatibility with standard temperature sensors, high temperature sensors, and sensors of a specialized nature. Refer to Figure 1 for FT10 non-invasive, nonmetallic flow-through sensors, and Figure 2 for 871FT flow-through sensors and 871EC Series sensors.

Figure 1. FT10 Non-Invasive, Nonmetallic Flow-Through Sensor

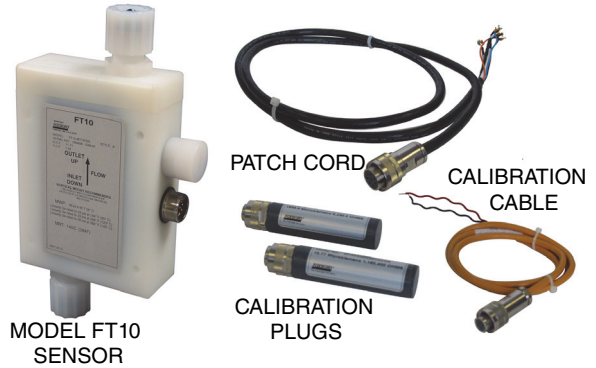

Figure 2. 871FT Industrial and Sanitary Flow-Through Sensors and 871EC Series Sensors



LOCAL HUMAN INTERFACE

A local human interface, as shown in Figure 3, provides local display, diagnostics, and setup. The interface consists of a 128 x 64 dot matrix LCD, a 12-key alpha-numeric keypad, 4 directional arrows, and an ENTER key. The user functions available via the local interface are also available through external interfaces.

The UP and DOWN arrows are used to scroll through menu selections, which wrap from the last to the first item. HELP messages appear at the bottom

of every display screen, except for measurement displays. If there is a fault, the fault symbol on the title bar will flash. And when the transmitter is in HOLD mode, this is indicated in the upper right of the display (see Figure 4 for location of displays).

A help display is accessed via the HELP function key. Help displays also appear before each calibration operation. A typical diagnostics display is shown in Figure 4, and a typical dual measurement display is shown in Figure 5.

DISPLAY SIZE AND FORMAT

The LCD viewing area is 2.80 in wide x 1.53 in high, and displays Measurements, Status, Configuration settings, and Calibration settings. You may configure the interface to display a single measurement, dual measurements, or triple measurements. Font sizes include extra large, large, medium, or small (depending on what is being displayed), and are sized to allow easy reading from a distance.

Figure 3. Local Human Interface

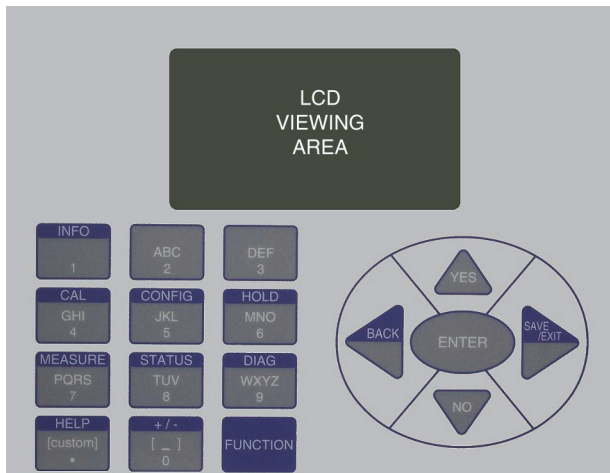

Figure 4. Typical Fault Display

View Faults	⚠
⚠	Electronics Service Now Watchdog: 0000
View all active faults	

Figure 5. Typical Dual Measurement Display

Hold Indicator	lfnl	⚠	HOLD
Measurements	345	mS/cm	
	31.8	degC	

DESIGNED WITH YOUR INDUSTRY IN MIND

The Foxboro brand has a long history in electrodeless conductivity measurement that has resulted in a comprehensive array of chemical concentration and temperature compensation transforms. These standard curves can be employed to optimize critical measurements in several common end user segments. Here are just a few examples of industry applications.

Pulp and Paper Industry Applications

- ▶ Dissolving Tank (Green Liquor) and Digester Alkali (Black Liquor) Temperature Compensation Curves
- ▶ White Liquor Concentration Control

Chemical Industry Applications

- ▶ Standard Concentration Curves for Common Electrolytes, as follows:
 - Acids: Sulfuric, Nitric, Hydrochloric, Phosphoric, Hydrofluoric, Acetic
 - Bases: Caustic, Potassium Hydroxide
 - Salts: Sodium Chloride, Potassium Chloride

Power Industry Applications

- ▶ Demineralization, Regeneration, and Concentration Control of Sodium Hydroxide and Sulfuric Acid
- ▶ Clean-In-Place (CIP) using Standard Caustic and Acid Curves
- ▶ Sodium Hydroxide Concentration Control for Pretzel Blanching
- ▶ Brine Density Control for Pea Grading

Metals and Mining Industry Applications

- ▶ Steel Pickling Bath Concentration Control

Semiconductor Industry Applications

- ▶ Acid Etching Solution Concentration Control

In all, Foxboro models offer 17 standard chemical concentration ranges and 22 temperature compensation types. And in the event your application is not covered, we readily share data from our application files to help you develop custom curves to optimize your conductivity measurement.

DATA AND CALIBRATION INTEGRITY

Two levels of defense help protect against unauthorized configuration/calibration changes, loss of data, and/or invalid measurement signals.

Two levels of passcode protection are provided. The first level permits access to routine maintenance functions, including calibration and output hold, as permitted by the second level of defense. The second level permits changes to configuration parameters by authorized personnel.

Data is stored in EEPROM, obviating the need for battery backup. Measurement loop integrity is enhanced by a user programmable “fail signal” parameter activated by any transmitter fault and certain serious sensor faults. This parameter forces the transmitter output to off-scale Fail High or Fail Low per NAMUR Standard NE 43.

DURABLE FIELD-MOUNTED ENCLOSURE

The 876EC is housed in an aluminum alloy enclosure, designed to withstand severe field conditions. The enclosure has dusttight and weatherproof rating of IP66 as defined by IEC 60529, and provides environmental and corrosion-resistant protection rating of NEMA 4X.

Its efficient DIN panel-size design allows easy mounting for panel, pipe, or surface applications. A hinged front door provides easy front access to field connections. Large spade lug terminals for sensor and communications connections facilitate quick maintenance and calibration procedures. The keypad overlay is constructed of polyester material.

The transmitter can also be provided with an optional clear plastic storm door to help prevent accidental activation of the front panel controls.

OPERATING, TRANSPORTATION, AND STORAGE CONDITIONS

Influence	Reference Operating Conditions	Normal Operating Conditions	Transportation and Storage Limits
Electronic Ambient Temperature	23 ± 2°C (73 ± 4°F)	-30 to +70°C (a) (-22 to +158°F)	-30 and +70°C (-22 and +158°F)
Display Ambient Temperature	23 ± 2°C (73 ± 4°F)	-30 to +70°C (b) (c) (-22 to +158°F)	-30 and +70°C (-22 and +158°F)
Relative Humidity	50 ± 10%	5 to 90% (c) Noncondensing	5 and 90% Noncondensing
Supply Voltage Over 4 to 20 mA 2-Wire Line	24 ± 2 V dc	12.8 to 42 V dc (see Figure 6)	Not Applicable
Output Load	250 Ω	0 to 1300 Ω (see Figure 6)	Not Applicable
Isolation	±1 V dc	For Intrinsically Safe Applications: ±24 V dc For General Purpose (Ordinary) Locations: ±42 V dc	Not Applicable
Vibration	Negligible	For Panel Mounting: 2.5 m/s ² (0.25 "g") from 5 to 200 Hz For Pipe or Surface Mounting: 10 m/s ² (1 "g") from 5 to 200 Hz	Inside Shipping Container

- a. Refer to the Electrical Safety Specifications section for a restriction in ambient temperature with certain electrical certifications.
- b. The LCD Indicator may have degraded performance between -20 and -30°C (-4 and -22°F).
- c. The transmitter will operate at a low limit of 0% RH but with a possible degradation of performance.

PERFORMANCE SPECIFICATIONS

Transmitter specifications are under reference operating conditions unless otherwise specified. Refer to sensor literature for sensor specifications.

Accuracy – Digital Measurement (Includes Non-Linearity, Hysteresis, and Repeatability)

±1% of absolute reading within specified range for sensor (see Table 1, Table 2, and Table 3).

Accuracy – Analog Output

Analog output accuracy is equal to the digital measurement accuracy plus an additional 0.04% of full scale (4 to 20 mA).

Accuracy – Solution Temperature

With 3-Wire 1000 Ω Platinum RTD

±0.03°C (±0.05°F)

With 3-Wire 100 Ω Platinum RTD

±0.1°C (±0.18°F)

With 2-Wire 100 Ω Platinum RTD

±0.5°C (±0.9°F)

MIL SPEC 100 Ohm RTD

±0.5°C (±0.9°F)

With 100 kΩ Thermistor

±0.1°C (±0.18°F) between 0 and 70°C
(32 and 158°F)

Ambient Temperature Effect on Digital Measurement Accuracy

The effect listed below is for a 28°C (50.4°F) change in transmitter temperature within Normal Operating Condition limits.

±1% of absolute reading within specified range for sensor (see Table 1, Table 2, and Table 3).

Ambient Temperature Effect on Analog Output Accuracy

Digital Measurement effect plus an additional ±0.01% of span per °C.

Ambient Temperature Effect on Solution Temperature Accuracy

The effect listed below is for a 28°C (50.4°F) change in transmitter temperature within Normal Operating Condition limits, unless otherwise indicated.

With 3-Wire 1000 Ω Platinum RTD

±0.03°C (±0.05°F)

With 3-Wire 100 Ω Platinum RTD

±0.1°C (±0.18°F)

With 2-Wire 100 Ω Platinum RTD

±0.5°C (±0.9°F)

With 100 kΩ Thermistor

±0.1°C (±0.18°F) between 0 and 70°C (32 and 158°F)

Relative Humidity Effect (5 to 95% RH)

No additional effect on performance specifications for noncondensing environments.

Supply Voltage and Load Effect

Digital

Less than 0.005% of the reading.

Analog

Less than 0.005% of analog scale per volt, in addition to digital effect.

Mounting Position Effect

Transmitter meets reference accuracy specifications for recommended mounting positions.

Output Signal Noise

Included in reference accuracy specifications.

Response Time

Response time is defined as a 90% response to a stepped input change.

Conductivity Measurement

Less than 5 s

Temperature (RTD) Measurement

Less than 5 s (without temperature prediction enabled)

Measurement Stability (Absolute Conductivity)

Stability listed is after six months (noncumulative): One additional accuracy interval allowed after six months without calibration, non cumulative.

Solution Temperature Measurement Stability

Stability listed is after six months (noncumulative): One additional accuracy interval allowed after six months without calibration, noncumulative.

Common Mode Rejection

120 dB, dc; or 50/60 Hz, ac; between loop and sensor (42 volts peak)

Minimum Output Span

Refer to Table 1, Table 2, and Table 3.

Maximum Output Span

100% of selected display format.

NAMUR Compliance

The transmitter complies with the following NAMUR Standards:

- ▶ NAMUR NE 21 for interference immunity requirements
- ▶ NAMUR 43 for analog overrange and underrange annunciations

Electromagnetic Compatibility (EMC)

The transmitter, when installed in accordance with MI 611-261, meets EMC directive 2014/30/EU.

EN 61326-1:2006, Electrical equipment for measurement, control and laboratory use - EMC requirements, Class A emission limits, and immunity requirements according to Table 2 for Industrial locations.

FUNCTIONAL SPECIFICATIONS

HART Communications

Configurable for either Analog (4 to 20 mA) or Multidrop Mode. Digital communications is provided in both modes based upon the FSK (Frequency Shift Keying) technique which alternately superimposes one of two different frequencies on the uninterrupted current carried by the two signal/power wires. The digital signal is fully scalable over the operating range of the sensor. Remote configuration is via a HART Communicator, a PC-based configurator (such as the Model PC50 or Model HHT50), or a DCS. Local configuration is via the integral local human interface keypad. The HART communication rate is 1200 baud and measurement updates are 1 time/s.

Direct Connectivity to Foxboro™ Distributed Control System

The transmitter can be connected directly to a Foxboro DCS using fieldbus modules (FBMs). A HART FBM applicable to your installation can be provided.

Solution Temperature Inputs

- ▶ Factory precalibrated from -30 to +200°C (-22 to +392°F)
- ▶ 100 Ω platinum RTD; 2 or 3 wires
- ▶ 1000 Ω platinum RTD; 2 or 3 wires
- ▶ 100 k Ω thermistor (thermistor is limited from -20 to 150°C)

Measurement Range (Selectable)

Solution Temperature

-30 to +200°C (-22 to +392°F)

Solution Conductivity, Temperature-Corrected

Refer to Table 1, Table 2, and, Table 3.

Table 1. 871EC and EP307 Ranges and Minimum Allowable Output Span for Selected Sensor, Units, and Display Format

871EC and EP307 Sensor Type	Units (a)	Selected Display Format (b) Low and High Limits of 1% Accuracy Range (c)										Min. Allow. Output Span
		0.9999		9.999		99.99		999.9		9999		
		Low	High	Low	High	Low	High	Low	High	Low	High	
AB, EV	µS/cm							79.4	5,880.0	196	1,470,000	235.2
	mS/m					7.94	588.00	19.6	147,000.0	20	147,000	23.52
	mS/cm	0.0794	5.8800	0.196	1,470.000	0.20	1,470.00	0.2	1,470.0	0	1,470	0.2352
	S/m	0.0196	147.0000	0.020	147.000	0.02	147.00	0.0	147.0			0.02352
BW, RE	µS/cm							59.4	4,400.0	147	1,100,000	176
	mS/m					5.94	440.00	14.7	110,000.0	15	110,000	17.6
	mS/cm	0.0594	4.4000	0.147	1,100.000	0.15	1,100.00	0.1	1,100.0	0	1,100	0.176
	S/m	0.0147	110.0000	0.015	110.000	0.01	110.00	0.0	110.0			0.0176
EP307, NL, PN, PX, TF	µS/cm							245.0	8,166.7	817	6,125,000	980
	mS/m					24.50	816.67	81.7	612,500.0	82	612,500	98
	mS/cm	0.2450	8.1667	0.817	6,125.000	0.82	6,125.00	0.8	6,125.0	1	6,125	0.98
	S/m	0.0447	9.8000	0.082	612.500	0.08	612.50	0.1	612.5	0	613	0.098
HP, PP, PT, SP	µS/cm							215.0	7,166.7	717	5,375,000	860
	mS/m					21.50	716.67	71.7	537,500.0	72	537,500	86
	mS/cm	0.2150	7.1667	0.717	5,375.000	0.72	5,375.00	0.7	5,375.0	1	5,375	0.86
	S/m	0.0392	8.6000	0.072	537.500	0.07	537.50	0.1	537.5	0	538	0.086
LB, UT	µS/m									1,700	56,667	6,800
	µS/cm					17.00	566.67	56.7	425,000.0	57	425,000	68
	mS/m			1.700	56.667	5.67	42,500.00	5.7	42,500.0	6	42,500	6.8
	mS/cm	0.0310	6.8000	0.057	425.000	0.06	425.00	0.1	425.0	0	425	0.068
	S/m	0.0057	42.5000	0.006	42.500	0.01	42.50	0.0	42.5			0.0068

- a. If Concentration or Custom units are selected, ranges correspond to selected Base Units.
- b. Maximum allowable output setting is equivalent to display format.
- c. Measurements are possible outside the low and high limits, but with reduced accuracy.

Table 2. 871FT Ranges and Minimum Allowable Output Span for Selected Sensors, Units, and Display Format

871FT Sensor Type	Units (a)	Selected Display Format (b) Low and High Limits of 1% Accuracy Range (c)										Min. Allow. Output Span
		0.9999		9.999		99.99		999.9		9,999		
		Low	High	Low	High	Low	High	Low	High	Low	High	
1C	µS/m											232000
	µS/cm									1,348	58,000	2320
	mS/m							134.8	5,800.0	580	1,450,000	232
	mS/cm			1.348	58.000	5.80	14,500.00	5.8	14,500.0	6	14,500	2.32
	S/m	0.1348	5.8000	0.580	1,450.000	0.58	1,450.00	0.6	1,450.0	1	1,450	0.232
1D	µS/m											82800
	µS/cm							295.7	6,900.0	2,070	5,175,000	828
	mS/m					29.57	690.00	207.0	517,500.0	207	517,500	82.8
	mS/cm	0.2957	6.9000	2.070	5,175.000	2.07	5,175.00	2.1	5,175.0	2	5,175	0.828
	S/m	0.0782	8.2800	0.207	517.500	0.21	517.50	0.2	517.5	0	518	0.0828
1E	µS/m											53600
	µS/cm							191.4	4,466.7	1,340	3,350,000	536
	mS/m					19.14	446.67	134.0	335,000.0	134	335,000	53.6
	mS/cm	0.1914	4.4667	1.340	3,350.000	1.34	3,350.00	1.3	3,350.0	1	3,350	0.536
	S/m	0.0506	5.3600	0.134	335.000	0.13	335.00	0.1	335.0			0.0536
1F	µS/m											22400
	µS/cm							130.1	5,600.0	560	1,400,000	224
	mS/m					13.01	560.00	56.0	140,000.0	56	140,000	22.4
	mS/cm	0.1301	5.6000	0.560	1,400.000	0.56	1,400.00	0.6	1,400.0	1	1,400	0.224
	S/m	0.0560	140.0000	0.056	140.000	0.06	140.00	0.1	140.0			0.0224
1G	µS/m									4,429	103,333	12400
	µS/cm					44.29	1,033.33	72.0	3,100.0	310	775,000	124
	mS/m			4.429	103.333	7.20	310.00	31.0	77,500.0	31	77,500	12.4
	mS/cm	0.0720	3.1000	0.310	775.000	0.31	775.00	0.3	775.0	0	775	0.124
	S/m	0.0310	77.5000	0.031	77.500	0.03	77.50	0.0	77.5			0.0124
1H	µS/m									2,714	63,333	7600
	µS/cm					27.14	633.33	190.0	475,000.0	190	475,000	76
	mS/m			2.714	63.333	19.00	47,500.00	19.0	47,500.0	19	47,500	7.6
	mS/cm	0.0718	7.6000	0.190	475.000	0.19	475.00	0.2	475.0	0	475	0.076
	S/m	0.0190	47.5000	0.019	47.500	0.02	47.50	0.0	47.5			0.0076
1J, 3J	µS/m									2,143	50,000	6000
	µS/cm					21.43	500.00	150.0	375,000.0	150	375,000	60
	mS/m			2.143	50.000	15.00	37,500.00	15.0	37,500.0	15	37,500	6
	mS/cm	0.0567	6.0000	0.150	375.000	0.15	375.00	0.2	375.0			0.06
	S/m	0.0150	37.5000	0.015	37.500	0.02	37.50					0.006

Table 2. 871FT Ranges and Minimum Allowable Output Span for Selected Sensors, Units, and Display Format (Continued)

871FT Sensor Type	Units (a)	Selected Display Format (b) Low and High Limits of 1% Accuracy Range (c)										Min. Allow. Output Span
		0.9999		9.999		99.99		999.9		9,999		
		Low	High	Low	High	Low	High	Low	High	Low	High	
2C	µS/m											90800
	µS/cm							324.3	7,566.7	2,270	5,675,000	908
	mS/m					32.43	756.67	227.0	567,500.0	227	567,500	90.8
	mS/cm	0.3243	7.5667	2.270	5,675.000	2.27	5,675.00	2.3	5,675.0	2	5,675	0.908
	S/m	0.0858	9.0800	0.227	567.500	0.23	567.50	0.2	567.5	0	568	0.0908
2D	µS/m											32400
	µS/cm							188.2	8,100.0	810	2,025,000	324
	mS/m					18.82	810.00	81.0	202,500.0	81	202,500	32.4
	mS/cm	0.1882	8.1000	0.810	2,025.000	0.81	2,025.00	0.8	2,025.0	1	2,025	0.324
	S/m	0.0306	3.2400	0.081	202.500	0.08	202.50	0.1	202.5			0.0324
2E	µS/m											20800
	µS/cm							120.8	5,200.0	520	1,300,000	208
	mS/m					12.08	520.00	52.0	130,000.0	52	130,000	20.8
	mS/cm	0.1208	5.2000	0.520	1,300.000	0.52	1,300.00	0.5	1,300.0	1	1,300	0.208
	S/m	0.0520	130.0000	0.052	130.000	0.05	130.00	0.1	130.0			0.0208
2F	µS/m									3,143	73,333	8800
	µS/cm					31.43	733.33	220.0	550,000.0	220	550,000	88
	mS/m			3.143	73.333	22.00	55,000.00	22.0	55,000.0	22	55,000	8.8
	mS/cm	0.0832	8.8000	0.220	550.000	0.22	550.00	0.2	550.0	0	550	0.088
	S/m	0.0220	55.0000	0.022	55.000	0.02	55.00	0.0	55.0			0.0088
2G	µS/m									1,714	40,000	4800
	µS/cm					17.14	400.00	120.0	300,000.0	120	300,000	48
	mS/m			1.714	40.000	12.00	30,000.00	12.0	30,000.0	12	30,000	4.8
	mS/cm	0.0454	4.8000	0.120	300.000	0.12	300.00	0.1	300.0			0.048
	S/m	0.0120	30.0000	0.012	30.000	0.01	30.00					0.0048
2H	µS/m									1,627	70,000	2800
	µS/cm					16.27	700.00	70.0	175,000.0	70	175,000	28
	mS/m			1.627	70.000	7.00	17,500.00	7.0	17,500.0	7	17,500	2.8
	mS/cm	0.0700	175.0000	0.070	175.000	0.07	175.00	0.1	175.0			0.028
	S/m	0.0070	17.5000	0.007	17.500	0.01	17.50					0.0028
2J	µS/m							571.4	13,333.3	929	40,000	1600
	µS/cm			5.714	133.333	9.29	400.00	40.0	100,000.0	40	100,000	16
	mS/m	0.5714	13.3333	0.929	40.000	4.00	10,000.00	4.0	10,000.0	4	10,000	1.6
	mS/cm	0.0400	100.0000	0.040	100.000	0.04	100.00	0.0	100.0			0.016
	S/m	0.0040	10.0000	0.004	10.000	0.00	10.00					0.0016

Table 2. 871FT Ranges and Minimum Allowable Output Span for Selected Sensors, Units, and Display Format (Continued)

871FT Sensor Type	Units (a)	Selected Display Format (b) Low and High Limits of 1% Accuracy Range (c)										Min. Allow. Output Span
		0.9999		9.999		99.99		999.9		9,999		
		Low	High	Low	High	Low	High	Low	High	Low	High	
3C	µS/m											120800
	µS/cm							431.4	10,066.7	702	30,200	1208
	mS/m					43.14	1,006.67	70.2	3,020.0	302	755,000	120.8
	mS/cm	0.4314	10.0667	0.702	30.200	3.02	7,550.00	3.0	7,550.0	3	7,550	1.208
	S/m	0.0702	3.0200	0.302	755.000	0.30	755.00	0.3	755.0	0	755	0.1208
3E	µS/m											42400
	µS/cm							151.4	3,533.3	1,060	2,650,000	424
	mS/m					15.14	353.33	106.0	265,000.0	106	265,000	42.4
	mS/cm	0.1514	3.5333	1.060	2,650.000	1.06	2,650.00	1.1	2,650.0	1	2,650	0.424
	S/m	0.0401	4.2400	0.106	265.000	0.11	265.00	0.1	265.0			0.0424
3F, 3G	µS/m											19600
	µS/cm							113.9	4,900.0	490	1,225,000	196
	mS/m					11.39	490.00	49.0	122,500.0	49	122,500	19.6
	mS/cm	0.1139	4.9000	0.490	1,225.000	0.49	1,225.00	0.5	1,225.0	0	1,225	0.196
	S/m	0.0490	122.5000	0.049	122.500	0.05	122.50	0.0	122.5			0.0196
3H	µS/m									3,571	83,333	10000
	µS/cm					35.71	833.33	250.0	625,000.0	250	625,000	100
	mS/m			3.571	83.333	25.00	62,500.00	25.0	62,500.0	25	62,500	10
	mS/cm	0.0945	10.0000	0.250	625.000	0.25	625.00	0.3	625.0	0	625	0.1
	S/m	0.0250	62.5000	0.025	62.500	0.03	62.50	0.0	62.5			0.01
4C	µS/m											23600
	µS/cm							137.1	5,900.0	590	1,475,000	236
	mS/m					13.71	590.00	59.0	147,500.0	59	147,500	23.6
	mS/cm	0.1371	5.9000	0.590	1,475.000	0.59	1,475.00	0.6	1,475.0	1	1,475	0.236
	S/m	0.0590	147.5000	0.059	147.500	0.06	147.50	0.1	147.5			0.0236
4E	µS/m									3,000	70,000	8400
	µS/cm					30.00	700.00	210.0	525,000.0	210	525,000	84
	mS/m			3.000	70.000	21.00	52,500.00	21.0	52,500.0	21	52,500	8.4
	mS/cm	0.0794	8.4000	0.210	525.000	0.21	525.00	0.2	525.0	0	525	0.084
	S/m	0.0210	52.5000	0.021	52.500	0.02	52.50	0.0	52.5			0.0084
4F, 4G	µS/m									1,286	30,000	3600
	µS/cm					12.86	300.00	90.0	225,000.0	90	225,000	36
	mS/m			1.286	30.000	9.00	22,500.00	9.0	22,500.0	9	22,500	3.6
	mS/cm	0.0340	3.6000	0.090	225.000	0.09	225.00	0.1	225.0			0.036
	S/m	0.0090	22.5000	0.009	22.500	0.01	22.50					0.0036

Table 2. 871FT Ranges and Minimum Allowable Output Span for Selected Sensors, Units, and Display Format (Continued)

871FT Sensor Type	Units (a)	Selected Display Format (b) Low and High Limits of 1% Accuracy Range (c)										Min. Allow. Output Span
		0.9999		9.999		99.99		999.9		9,999		
		Low	High	Low	High	Low	High	Low	High	Low	High	
4H	µS/m									1,162	50,000	2000
	µS/cm					11.62	500.00	50.0	125,000.0	50	125,000	20
	mS/m			1.162	50.000	5.00	12,500.00	5.0	12,500.0	5	12,500	2
	mS/cm	0.0500	125.0000	0.050	125.000	0.05	125.00	0.1	125.0			0.02
	S/m	0.0050	12.5000	0.005	12.500	0.01	12.50					0.002
4J	µS/m							428.6	10,000.0	697	30,000	1200
	µS/cm			4.286	100.000	6.97	300.00	30.0	75,000.0	30	75,000	12
	mS/m	0.4286	10.0000	0.697	30.000	3.00	7,500.00	3.0	7,500.0	3	7,500	1.2
	mS/cm	0.0300	75.0000	0.030	75.000	0.03	75.00	0.0	75.0			0.012
	S/m	0.0030	7.5000	0.003	7.500	0.00	7.50					0.0012

- a. If Concentration or Custom units are selected, ranges correspond to selected Base Units.
- b. Maximum allowable output setting is equivalent to display format.
- c. Measurements are possible outside the low and high limits, but with reduced accuracy.

Table 3. FT10 Ranges and Minimum Allowable Output Span for Selected Sensor, Units, and Display Format

FT10 Sensor Type	Units (a)	Selected Display Format (b) Low and High Limits of 1% Accuracy Range (c)										Min. Allow. Output Span
		0.9999		9.999		99.99		999.9		9,999		
		Low	High	Low	High	Low	High	Low	High	Low	High	
-08	µS/cm									742	54,900	2,196
	mS/m							74.2	5,490.0	183	1,372,500	219.6
	mS/cm			0.742	54.900	1.83	13,725.00	1.8	13,725.0	2	13,725	2.196
	S/m	0.0742	5.4900	0.183	1,372.500	0.18	1,372.50	0.2	1,372.5	0	1,373	0.2196
-12	µS/cm							154.0	5,133.3	513	3,850,000	616
	mS/m					15.40	513.33	51.3	385,000.0	51	385,000	61.6
	mS/cm	0.1540	5.1333	0.513	3,850.000	0.51	3,850.00	0.5	3,850.0	1	3,850	0.616
	S/m	0.0281	6.1600	0.051	385.000	0.05	385.00	0.1	385.0			0.0616
-16	µS/cm							121.0	4,033.3	403	3,025,000	484
	mS/m					12.10	403.33	40.3	302,500.0	40	302,500	48.4
	mS/cm	0.1210	4.0333	0.403	3,025.000	0.40	3,025.00	0.4	3,025.0	0	3,025	0.484
	S/m	0.0221	4.8400	0.040	302.500	0.04	302.50	0.0	302.5			0.0484

- a. If Concentration or Custom units are selected, ranges correspond to selected Base Units.
- b. Maximum allowable output setting is equivalent to display format.
- c. Measurements are possible outside the low and high limits, but with reduced accuracy.

Fail Safe Output

Fail Safe output is configurable to Off, Fail Low or Fail Hi. The factory default is Off.

- ▶ Off: The analog output continues to produce the available measurement without necessarily indicating a failure.
- ▶ Fail Low or Fail Hi: User-configurable to Fail Low (3.6 mA) or Fail Hi (22 mA) upon failure, consistent with NAMUR Standard NE 43.

Analog Outputs

- ▶ Configurable to Concentration, Conductivity or Temperature
- ▶ Linear Output within Measurement Range
- ▶ Analog Output Hold Function
- ▶ Analog Output Configurable to Fail Safe

Digital Outputs

1st Digital Measurement

Independently assignable to conductivity (absolute or temperature compensated), temperature sensor resistance, solution temperature, cell resistance, or chemical concentration (if selected). Also, the primary measurement (PV) is automatically assigned as the analog output.

2nd, 3rd, and 4th Digital Measurements

Independently assignable to conductivity, concentration, temperature sensor resistance, solution temperature, or cell resistance.

Factory Default Settings

- ▶ PV = Conductivity Measurement, temperature compensated
- ▶ SV = Solution Temperature
- ▶ TV = Conductivity Measurement, absolute
- ▶ QV = Temperature Sensor Resistance

Output Hold

Output Hold is a feature that allows sensor maintenance such as cleaning or calibration without control system upsets. Both digital and analog outputs are configured by output hold.

- ▶ Off: The dynamic output tracks the live sensor readings.
- ▶ On Present: The output remains frozen at the last value when output hold was invoked.
- ▶ On Manual: Output held at preconfigured values.

Output hold can also be configured for automatic engagement during calibration and configuration sessions.

Temperature Compensation

Temperature compensation converts the absolute conductivity measured at the actual solution temperature to the conductivity that the selected chemical would have at a fixed reference temperature. See Table 4 for supported compensations.

Measurement Damping

Measurement damping is continuously adjustable from 1 to 300 seconds.

Supply Voltage Requirements and External Loop Load Limitations

4 to 20 mA Output. See Figure 6.

Figure 6. 4 to 20 mA Output, Supply Voltage vs. Output Load

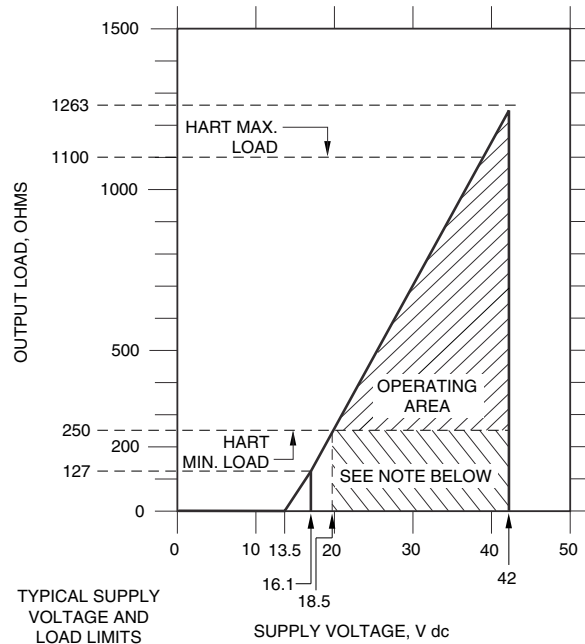

V dc	Load (Ohms)
24	445
30	717

NOTES

1. The minimum and maximum loads for the HART communicator are 250 Ω and 1100 Ω respectively.
2. The transmitter can function with an output load outside these limits provided that a remote configurator or HART communicator is not connected to it. Connecting a remote configurator or HART communicator while operating outside these limits could cause output and/or communication disturbances.

Table 4. Supported Compensations for Conductivity Measurements

Chemical	Reference Temperature	Temperature Range	Absolute Range	Temperature Compensated Range	Concentration Range
Absolute	N/A	Instrument Range	Instrument Range	Instrument Range	N/A
NaCl	25°C	0 to 200°C	0 to 1201 mS/cm	0 to 252 mS/cm	0 to 28%
Sea Water	25°C	0 to 120°C	Instrument Range	Not Specified	N/A
KCl	25°C (a)	0 to 50°C	0 to 356 mS/cm	0 to 237 mS/cm	0 to 16%
CH ₃ COOH	25°C	0 to 110°C	0 to 2.85 mS/cm	0 to 1.83 mS/cm	0 to 15%
H ₃ PO ₄	25°C	4.4 to 93.3°C	0 to 300 mS/cm	0 to 210 mS/cm	0 to 36%
HCl	25°C	-10 to +122°C	0 to 1860 mS/cm	0 to 825 mS/cm	0 to 15%
H ₂ SO ₄	25°C (a)	5 to 110°C	0 to 1440 mS/cm	0 to 800 mS/cm	0 to 25%
	30°C	20 to 90°C	34 to 435 mS/cm	43 to 150 mS/cm	99.5 to 93%
	50°C	-10 to +120°C	24 to 613 mS/cm	60 to 234 mS/cm	99.5 to 93%
Oleum	65°C	32 to 120°C	19 to 176 mS/cm	27 to 80 mS/cm	0 to 10%
			10 to 176 mS/cm	15 to 80 mS/cm	42 to 18%
HNO ₃	25°C	-10 to +120°C	0 to 893 mS/cm	0 to 525 mS/cm	0 to 10%
NaOH	25°C (a)	0 to 120°C	0 to 1176 mS/cm	0 to 420 mS/cm	0 to 15%
	50°C	0 to 100°C	0 to 987 mS/cm	0 to 616 mS/cm	0 to 15%
		50 to 100°C	0 to 1090 mS/cm	0 to 681 mS/cm	0 to 17%
100°C	75 to 122°C	0 to 1560 mS/cm	0 to 1300 mS/cm	0 to 22%	
KOH	25°C	10 to 55°C	0 to 750 mS/cm	0 to 500 mS/cm	0 to 15%
HF	0°C	-10 to +208°C	0 to 922 mS/cm	0 to 485 mS/cm	100 to 90%
	20°C (a)	0 to 50°C	0 to 1350 mS/cm	0 to 1110 mS/cm	0 to 70%
Kraft Green Liquor	85°C	35 to 95°C	Instrument Range	Not Specified	N/A
Kraft Black Liquor	160°C	100 to 175°C	Instrument Range	Not Specified	N/A
Linear	As Entered	Instrument Range	Instrument Range	Not Specified	N/A
Custom	As Entered	As Entered	Instrument Range	Not Specified	As Entered

a. Patented 3D Temperature Compensation

Continuous Diagnostics (Digital and Analog)

Check every eight seconds for diagnostics listed in the paragraphs that follow unless otherwise noted. When diagnostics fail, an indicator is displayed alternating with the main measurement. Additional information can then be obtained in the diagnostics menu. Diagnostic failures are reported via the HART digital protocol. Many will also cause an analog Fail Safe condition as noted below.

Background Sensor Diagnostics (All Fail Safe)

- ▶ Liquid Leakage into Sensor
- ▶ Measurement Range Checks
- ▶ Temperature Sensor Range Checks (short, open, off table)

NOTE

Fail Safe = this diagnostic will cause the output to go to Fail Safe if Fail Safe is configured ON.

Background Electronics Self-Diagnostics (All Fail Safe)

- ▶ Checksum, EEPROM, EPROM, and RAM Image of Database
- ▶ Code Space Checksum (every 5 minutes)
- ▶ Stack Checking
- ▶ Watch-Dog Timer
- ▶ Verify Readable Processor Registers
- ▶ Analog to Digital Converter

Application Diagnostics

- ▶ Compensation Range Checks (outside selected range for temperature compensation or concentration). Causes Fail Safe, if enabled.
- ▶ Analog Output Overrange and Underrange. Causes Fail Safe, if enabled.

Sensor Compatibility

- ▶ 871EC Electrodeless Conductivity Sensors
- ▶ 871FT Non-Invasive Sanitary and Industrial Electrodeless Flow-Through Conductivity Sensors
- ▶ EP307B Thermoplastic Electrodeless Conductivity Sensors
- ▶ EP307G Glass Electrodeless Conductivity Sensors
- ▶ FT10 Non-Invasive, Nonmetallic Electrodeless Flow-Through Conductivity Sensors

On-Demand Measurement Indicators

Indicators available to the user in Status mode by pressing the DOWN ARROW key.

- ▶ Solution Temperature Display
- ▶ Absolute Input Display
- ▶ Compensated Measurement Display
- ▶ HART PV
- ▶ HART SV
- ▶ HART TV
- ▶ HART QV
- ▶ Analog Output

Calibration

For each user calibration, you are provided with detailed, step by step instructions.

Valid Configuration Check

Once a user configuration session is complete, the configuration is validated as a whole. If valid, you can choose to accept the configuration or abort and return to the previous configuration.

If any part of the configuration is invalid, the problem is indicated to you, and you can choose to fix it or abort.

History Log

A history log of the 100 most recent events is stored in nonvolatile memory. Events include power up, diagnostic detection, pass code entry, configuration, calibration, output hold entry and exit, and application switches.

Passcode

Two user passcode levels are supported.

Externally Initiated Functions (Auto Service)

The transmitter offers the following functions which may be initiated by an external control system:

- ▶ Activate Output Hold
- ▶ Low and High Solution Calibrations
- ▶ Release Output Hold

Write Protect Jumper

A write protect jumper provides additional defense by allowing you to help prevent the local indicator (configurator) and remote configurator from writing to the electronics. Write protection fulfills the security requirements for safety systems.

Functional Block Diagrams

Refer to Figure 7 and Figure 8.

Figure 7. HART 4 to 20 mA Topology

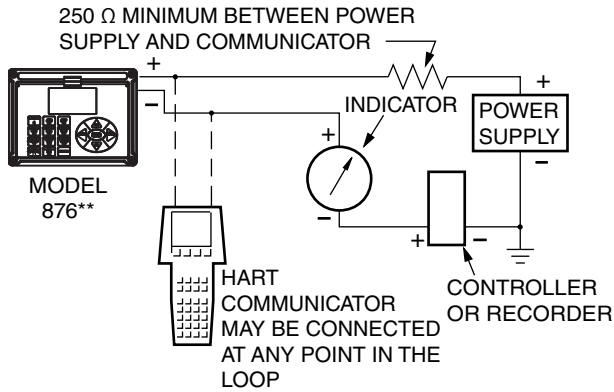
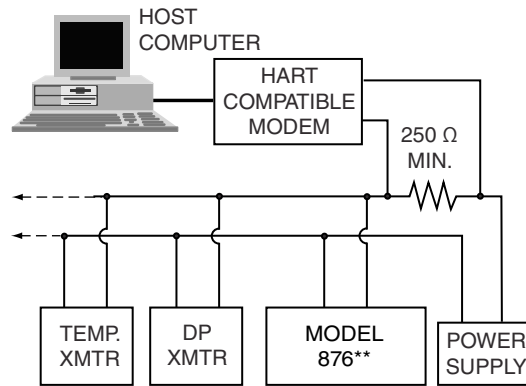

Figure 8. HART Multidrop Topology



PHYSICAL SPECIFICATIONS

Transmitter Enclosure

The transmitter enclosure comprises a housing and hinged bezel assembly. The bezel assembly is sealed to the housing with captive screws, with a gasket seal between them.

Housing and Bezel Material

- ▶ Aluminum alloy (with a maximum copper content of 1%).
- ▶ Clear lexan window on bezel assembly.

Gasket Material

- ▶ Silicone Rubber, Electrically Conductive.

Environmental and Corrosion Resistant Protection

The enclosure has the dust tight and weatherproof rating of IP66 as defined by IEC 60529, and provides the environmental and corrosion resistant protection rating of NEMA 4X.

Storm Door (Optional)

Made from a 0.090 inch thick, clear plastic.

Keypad

Durable polyester

Display

Liquid Crystal Display (LCD)

Transmitter Mounting

The transmitter can be panel-mounted, surface-mounted, or mounted to a DN 50 or 2-in pipe. A bracket is provided for surface or pipe mounting. Refer to "DIMENSIONS - NOMINAL" on page 23 for mounting details.

Sensor Cable Length

30 m (100 ft) maximum

Approximate Weight

Panel Mounted Transmitter

3.1 kg (6.8 lb)

Surface/Pipe Mounted Transmitter

3.7 kg (8.1 lb); includes mounting bracket.

Electrical Connections

Field wires enter through three cable entry holes at the lower surface of the housing, and terminate at screw terminals located on an electronics PWA located within the enclosure. These terminals are accessible by swinging down the hinged front cover.

The cable entry holes are sized to accommodate standard wiring conduit or cable glands. The electrical connections are shown in Figure 9.

Figure 9. Electrical Connections

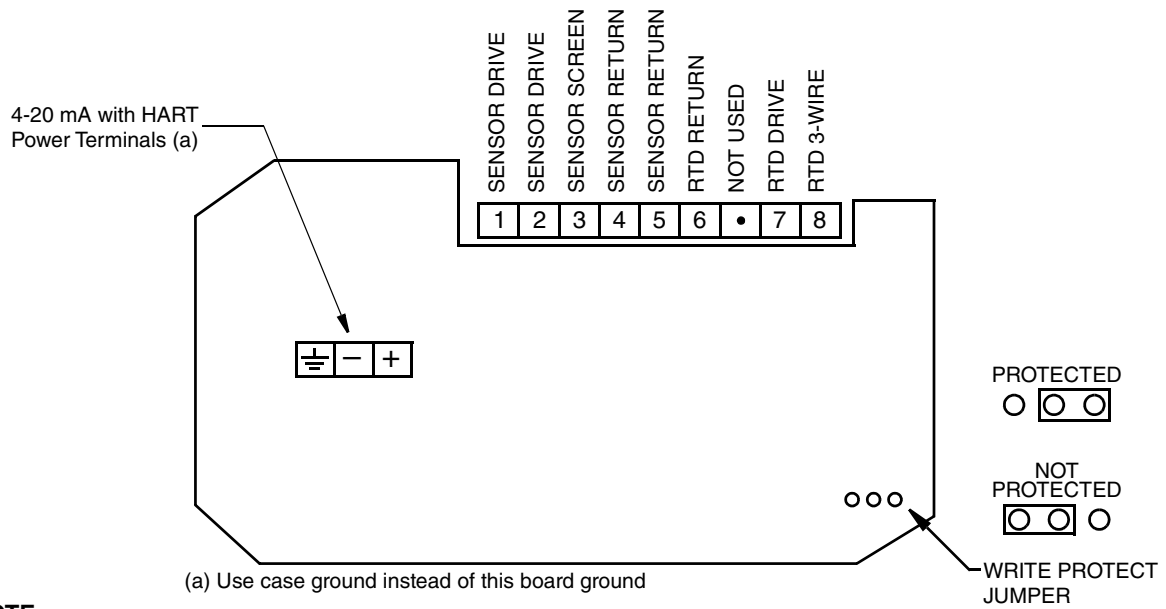

NOTE:

There must be at least 250 ohms total resistance between the PC-based configurator or HART communicator and the power supply.

ELECTRICAL SAFETY SPECIFICATIONS

Entity Parameters are as listed below:

- ▶ Intrinsically Safe Entity Parameters: $V_{\max} = 30 \text{ V}$, $I_{\max} = 110 \text{ mA}$, $P_{\max} = 0.8 \text{ W}$
- ▶ Nonincendive Entity Parameters: $V_{\max} = 42 \text{ V}$, $I_{\max} = 22 \text{ mA}$
- ▶ Sensor Output Entity Parameters: $V_o = 6.5 \text{ V}$, $I_o = 110 \text{ mA}$, $P_o = 100 \text{ mW}$

Testing Laboratory, Types of Protection and Area Classification	Application Conditions	Electrical Safety Design Code
ATEX II 1 G, Ex ia IIC, intrinsically safe for Zone 0.	Temperature Class T4. Ta = -20 to +60°C.	AA
ATEX II 3 G, Ex ic IIC, intrinsically safe for Zone 2.	Temperature Class T4. Ta = -20 to +60°C.	AN
CSA Ex ia IIC; intrinsically safe for Zone 0; and CSA intrinsically safe, Class I, II, III, Division 1, Gas Groups A, B, C, D, E, F, G.	Temperature Class T4. Ta = -20 to +60°C.	CA
CSA Ex nL IIC; energy limited for Zone 2; and CSA for Class I, II, III, Division 2, Gas Groups A, B, C, D, E, F, G.	Temperature Class T4. Ta = -20 to +60°C.	CN
FM and FMc AEx ia IIC; intrinsically safe for Zone 0; and FM and FMc intrinsically safe, Class I, II, III, Division 1, Gas Groups A, B, C, D, E, F, G.	Temperature Class T4. Ta = -20 to +60°C.	FA
FM and FMc AEx nC IIC; nonincendive for Zone 2; and FM and FMc nonincendive, Class I, II, III, Division 2, Gas Groups A, B, C, D, E, F, G.	Temperature Class T4. Ta = -20 to +60°C.	FN
IECEx Ex ia IIC; intrinsically safe for Zone 0.	Temperature Class T4. Ta = -20 to +60°C.	DA
IECEx Ex ic IIC; intrinsically safe for Zone 2.	Temperature Class T4. Ta = -20 to +60°C.	DN
NEPSI Ex ia IIC Ga; intrinsically safe for Zone 0.	Temperature Class T4. Ta = -20 to +60°C.	NA
NEPSI Ex ic IIC Gc; intrinsically safe for Zone 2.	Temperature Class T4. Ta = -20 to +60°C.	NN
EAC 0 Ex ia IIC X; intrinsically safe for Zone 0.	Temperature Class T4. Ta = -20 to +60°C.	RA
EAC 2 Ex ic IIC X; intrinsically safe for Zone 2. EAC 2 Ex nL IIC X; Limited Energy for Zone 2.	Temperature Class T4. Ta = -20 to +60°C.	RN
No Certifications	N/A	ZZ

MODEL CODE

Description	Model
Electrodeless Conductivity Intelligent Transmitter	876EC
Output Signal HART and 4 to 20 mA Output	-T
Enclosure Mounting Panel Mounting Surface Mounting Pipe Mounting (Horizontal or Vertical Pipe)	W X Y
Electrical Safety (Also see "ELECTRICAL SAFETY SPECIFICATIONS" on page 21)	
ATEX, II 1 G, Ex ia IIC, intrinsically safe, Zone 0	AA
ATEX, II 3 G, Ex ic IIC, intrinsically safe, Zone 2	AN
CSA, Ex ia IIC, intrinsically safe, Class I, II and III, Division 1, Zone 0	CA
CSA, Ex nL IIC, nonincendive, Class I, II and III, Division 2, Zone 2	CN
FM, AEx ia IIC, intrinsically safe, Class I, II, and III, Division 1, Zone 0	FA
FM, AEx nC IIC, nonincendive, Class I, II, and III, Division 2, Zone 2	FN
IECEX, Ex ia IIC, intrinsically safe, Zone 0	DA
IECEX, Ex ic IIC, intrinsically safe, Zone 2	DN
NEPSI, Ex ia IIC Ga; intrinsically safe for Zone 0	NA
NEPSI, Ex ic IIC Gc; intrinsically safe for Zone 2	NN
EAC, 0 Ex ia IIC X; intrinsically safe for Zone 0	RA
EAC, 2 Ex ic IIC X; intrinsically safe for Zone 2	RN
EAC, 2 Ex nL IIC X; Limited Energy for Zone 2	
No Certification	ZZ
Optional Selections	
Special per Engineering Order (a)	-1
Storm Door (b)	-7
Detailed Instruction Manual (c)	-M
Example: 876EC-TXFA-7	

- a. Provides ability to preconfigure the instrument with custom temperature compensation.
- b. Used to help protect front panel controls, particularly in field mounting applications.
- c. A DVD-ROM is shipped as standard with each transmitter.

DIMENSIONS - NOMINAL

mm
in

TRANSMITTER ASSEMBLY

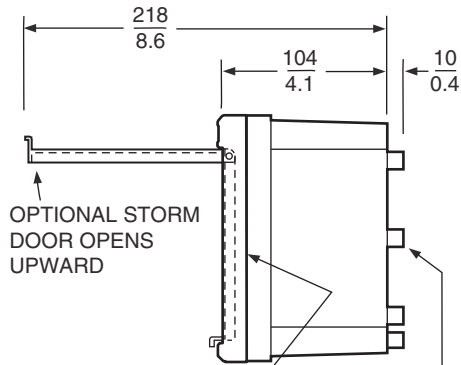
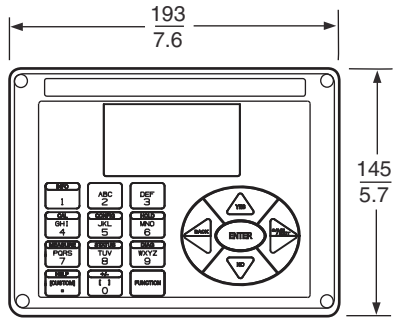

FRONT COVER
HINGES
DOWNWARD

FOUR BOSSES ON REAR SURFACE
TAPPED 0.250-20, 6.4 mm (0.25 in)
DEEP ARE USED FOR SURFACE OR
PIPE MOUNTING OF TRANSMITTER.
CENTERS OF BOSSES ARE ON A
89 mm (3.5 in) BOLT CIRCLE.

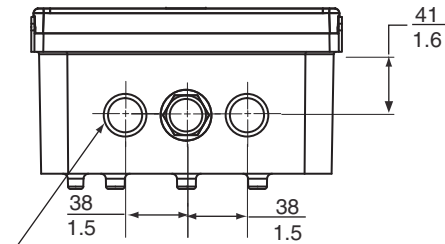

TWO 22 mm (0.87 in) DIAMETER
HOLES FOR FIELD WIRING ENTRY.
NEMA PLUG IN CENTER HOLE CAN
BE REMOVED FOR ADDITIONAL WIRING.

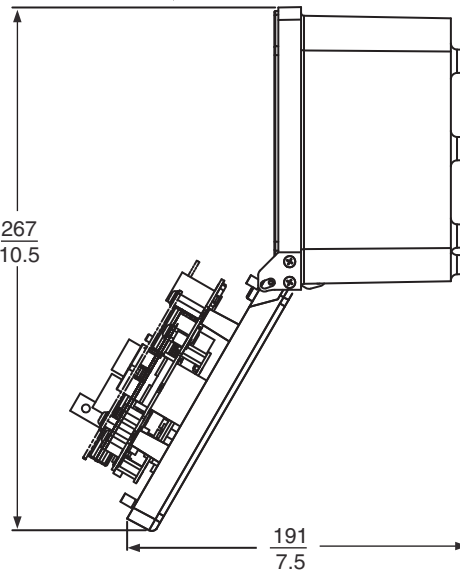

TRANSMITTER MOUNTING

$\frac{\text{mm}}{\text{in}}$

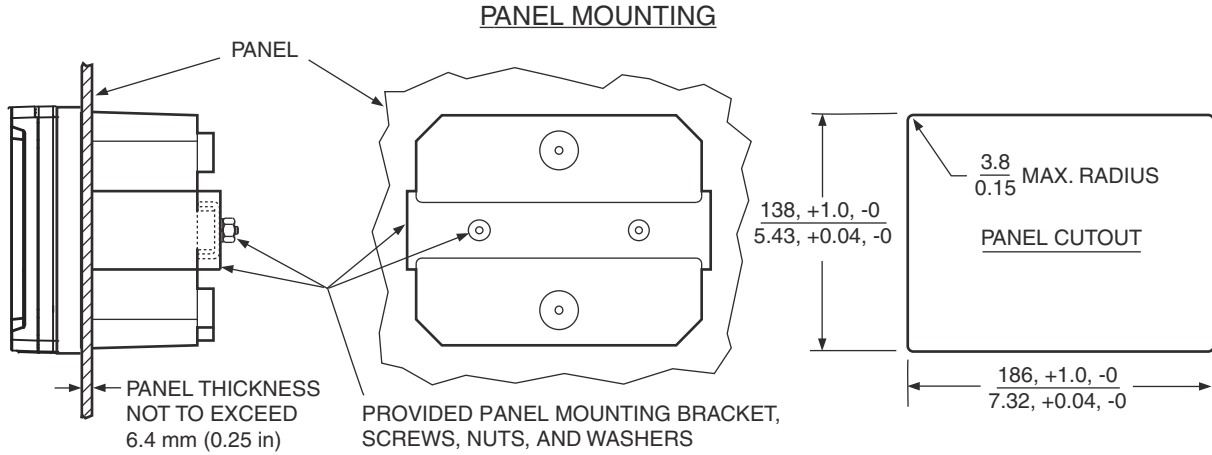

SURFACE MOUNTING

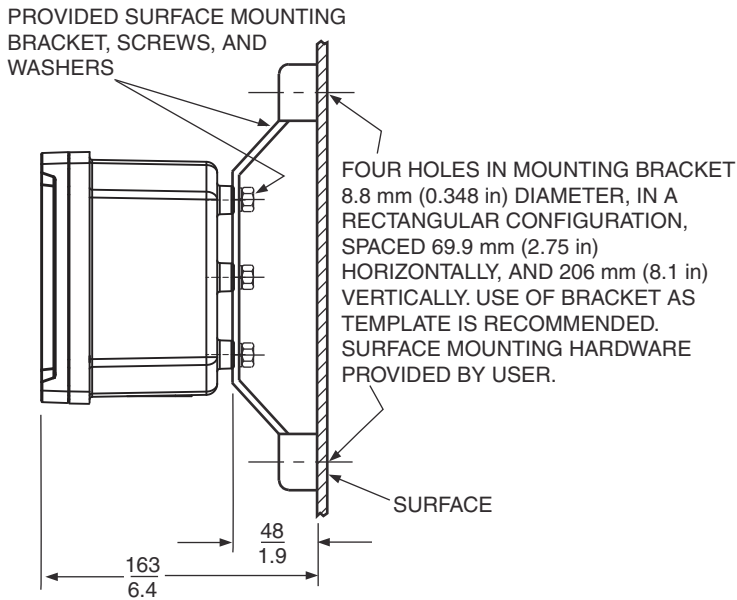

PIPE MOUNTING

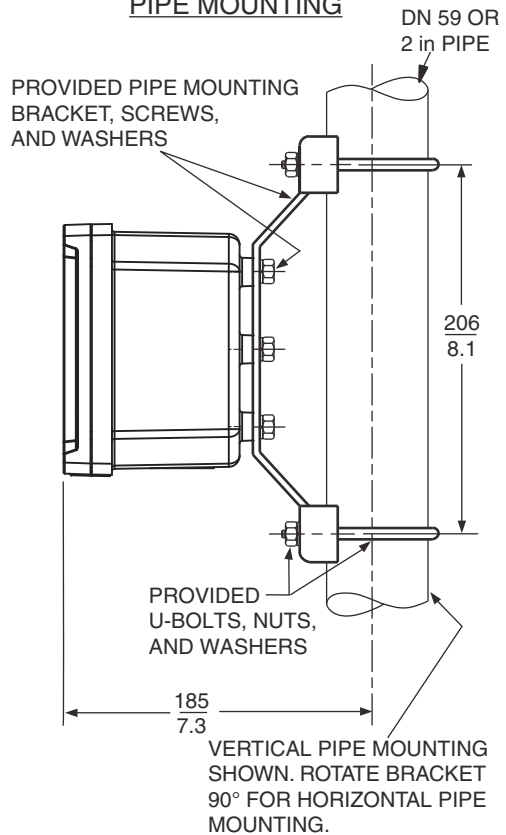

REFERENCE DOCUMENTS

Document Number	Document Description
PSS 2A-1Z3 G	Model PC50 Field Device Tool (FDT) for Use with Intelligent Field Devices
PSS 2A-1Z3 L	Model HHT Configurator for Use with Intelligent Field Devices
PSS 6-3C4 A	871EC Series Electrodeless Conductivity Sensors
PSS 6-3Q1 A	871FT Series Non-invasive Sanitary and Industrial Electrodeless Flow-Through Conductivity Sensors
PSS 6-3Q1 B	FT10 Series Non-Invasive Nonmetallic Electrodeless Flow-Through Conductivity Sensors
Bulletin K99-5B	EP307B Series Thermoplastic Electrodeless Conductivity Sensors
Bulletin K99-6	EP307G Series Glass Electrodeless Conductivity Sensors
MI 611-261	876EC Intelligent Transmitter for Electrodeless Conductivity Measurements
MI 611-206	Intrinsic Safety Connector Diagrams - FM, CSA, and IECEx
MI 611-208	Electrochemical Products Product Safety Information - ATEX
MI 611-220	Electrodeless Conductivity System Calibration Examples
Bulletin K99-8	EP485A - Calibration Plugs for Use with 871FT Sensors
Bulletin K99-9	EP485N - Calibration Plugs for Use with 871FT -8/-9 Sensors
Bulletin K99-10	EP485Q - Calibration Plugs for Use with 871EC and EP307 Sensors
Bulletin K107	Sensor Selector Wheel

NOTES



ORDERING INSTRUCTIONS

1. Model Number.
2. Measuring Sensor Type; 871EC-SP, -PP, -PT, -RE, -LB, -HP, -BW, -UT, -NL, -TF, or -EV; or full Model Code of 871FT Flow-Through Sensor; or full Model Code of FT10 Sensor.
3. Measurement Display Format (example 9.999 mS/cm).
4. Temperature Compensation Type.
5. Analog Output Range.
6. Temperature Compensation Input;
 - ▶ 871EC-SP, -PT, -RE, -LB, -TF, -EV use 100 K Ω thermistor
 - ▶ 871EC-HP, -BW, -UT, PP use 100 Ω RTD, 2-wire
 - ▶ 871EC-FT or FT10 RTD Code "R" use 1000 Ω RTD, 3-wire
 - ▶ 871EC-FT, RTD Code "T" use 100 Ω RTD, 2-wire
 - ▶ FT10 Code "T" use 100 Ω RTD, 3-wire
7. User Tag and Application.

ADDITIONAL PRODUCTS

These product lines offer a broad range of measurement and instrument products, including solutions for pressure, flow, analytical, temperature, positioning, controlling, and recording.

For a list of these offerings, visit our web site at:

www.schneider-electric.com

Schneider Electric Systems USA, Inc.
38 Neponset Avenue
Foxboro, MA 02035
United States of America
<http://www.schneider-electric.com>

Global Customer Support
Inside U.S.: 1-866-746-6477
Outside U.S.: 1-508-549-2424
<https://pasupport.schneider-electric.com>

Copyright 2011-2018 Schneider Electric
Systems USA, Inc. All rights reserved.

Schneider Electric and Foxboro are trademarks
of Schneider Electric Systems USA, Inc., its
subsidiaries, and affiliates. All other trademarks
are the property of their respective owners.

