

**871CR Series**  
**Contacting Conductivity/Resistivity**  
**Sensors and Accessories**

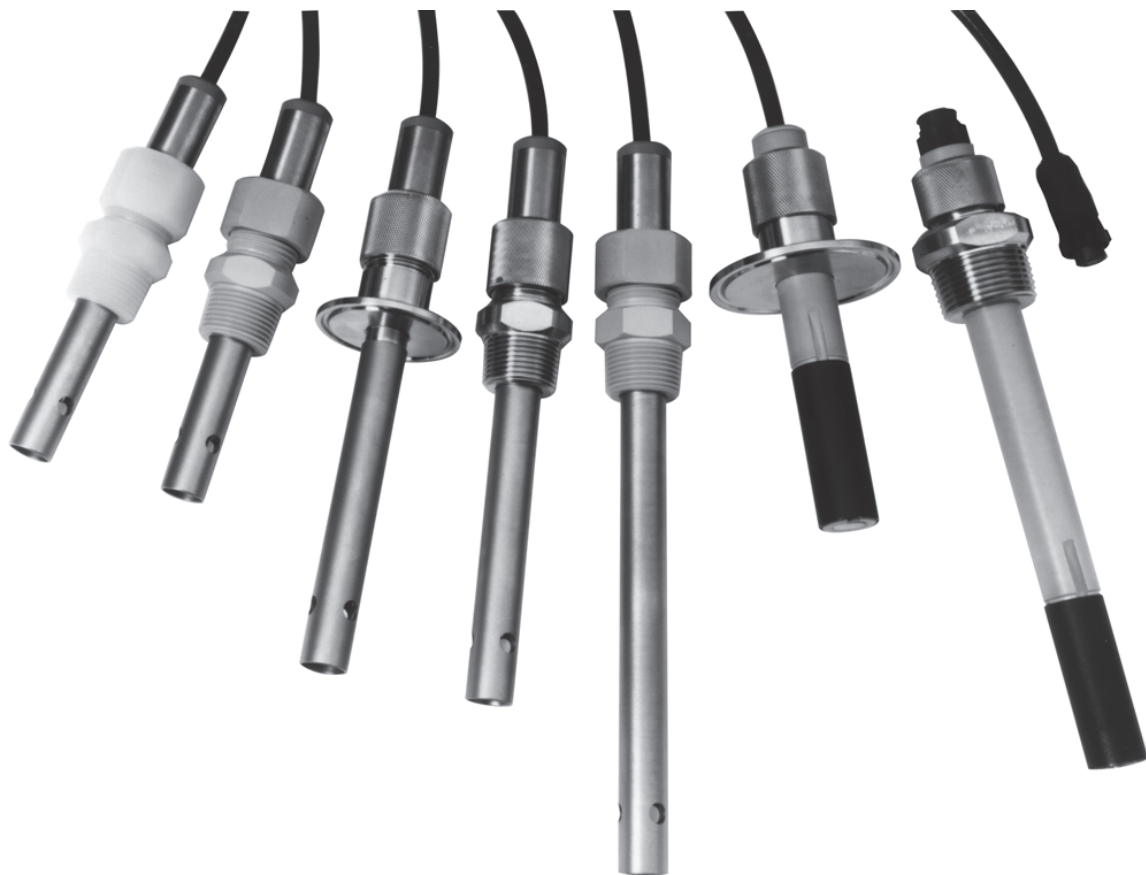



# Contents

Figures .....	v
Tables .....	vii
<b>1. Introduction .....</b>	<b>1</b>
General .....	1
Reference Documents .....	1
Model Code .....	2
Standard Specifications .....	4
Sensor Identification .....	5
Theory of Operation .....	6
<b>2. Installation .....</b>	<b>7</b>
General Installation Guidelines .....	7
Installation of the Sensor .....	8
Mounting Types A, B, C, D, E, K with Accessory Bushing .....	8
Mounting Type F or Type J with Tri-Clamp Fitting .....	12
Mounting Types J or K in Schneider Electric Flanges .....	13
Installation of Insertion Sensor (Mounting Type G) .....	14
Installation of Insertion Sensor (Mounting Type H) .....	17
Sensor Wiring .....	20
Connecting to an 870ITCR Transmitter .....	20
Connecting to an 875CR Analyzer .....	21
<b>3. Calibration .....</b>	<b>23</b>
Selection of Proper Sensor .....	23
Calibrations in Ultrapure and Pure Water Applications (0.1 cm <sup>-1</sup> Cell Factor) .....	23
Calibrations for Conductivity Ranges above 50 µS/cm (0.1 and 10 cm <sup>-1</sup> Cell Factor) .....	24
How to Prepare Conductivity Standards .....	24
<b>4. Maintenance .....</b>	<b>27</b>
Process Temperature versus Temperature Sensor Resistance .....	27
Electrode Inspection .....	27
Cleaning the Electrode .....	28
Replacing the Sensor in Sensor Mounting Type G .....	29



# Figures

1	871CR Sensors.....	6
2	In-line Installation of Sensor Mounting Types A Through E .....	8
3	Installation of Sensor Mounting Types A Through E in Flow Chamber.....	11
4	Installation of Sensor Type F .....	13
5	PVDF Ball Valve Assembly and Insertion Sensor Assembly .....	16
6	Insertion of Sensor Mounting H into the Stainless Steel Ball Valve.....	18
7	Sensor Identification .....	24
8	Immersion Portion of Sensors .....	28
9	Replacing the Sensor in the Sensor Mounting Type G .....	29



# Tables

1	Measurement Ranges with a Model 870ITCR Transmitter or a Model 875CR Analyzer .....	4
2	Product Safety Specifications .....	5
3	Torque Values for Mounting Bushings .....	9
4	Maximum Pressure/Temperature Ratings for Sensors in Bushing Mounts .....	10
5	Maximum Pressure/Temperature Ratings for Flow Chambers .....	12
6	Flow Rates.....	12
7	Maximum Pressure/Temperature Ratings for Sensors in Tri-Clamp Mountings .....	13
8	Pressure/Temperature Ratings for Sensors in Flange Mounts .....	14
9	PVDF Ball Valve Assembly Specifications.....	14
10	Pressure/Temperature Ratings for Ball Valve Insertion Sensor .....	15
11	Stainless Steel Ball Valve Assembly Specifications .....	17
12	Pressure/Temperature Ratings for Ball Valve Insertion Sensor .....	17
13	Wiring Connections at 870ITCR Transmitter.....	20
14	Wiring Connections at 875CR Analyzer .....	21
15	Preparation of Conductivity Standards .....	25
16	Process Temperature vs. Temperature Sensor Resistance.....	27





# 1. Introduction

## General

The 871CR Conductivity/Resistivity Sensors are used with Schneider Electric 870ITCR Transmitters and 875CR Analyzers to measure conductivity or resistivity of process fluids. Two cell factor selections cover a wide range of measurements from ultrapure water to low concentrations of soluble acids, bases, and ionized salts. Sensors with cell factors of  $0.1 \text{ cm}^{-1}$  are calibrated by either using NIST traceable procedures or in an ultrapure water loop for optimum resistivity measurements. All sensors use a  $1000 \Omega$  Platinum RTD to provide accurate temperature measurement and compensation and are designed with a “universal” bore piece for use with several flanges and bushings for piping and tank installations.

## Reference Documents

Document Number	Description
MI 611-216	Instruction – 870ITCR Intelligent Conductivity/Resistivity Transmitter
MI 611-222	Instruction – 875CR Intelligent Conductivity/Resistivity Analyzer
DP 611-165	Dimensional Print – 871CR Conductivity/Resistivity Sensors Universal Bore Piece
DP 611-166	Dimensional Print – 871CR Conductivity/Resistivity Sensors Bushing Mounted
DP 611-167	Dimensional Print – 871CR Sensor Universal Bore Piece with Cable Connector or Conduit Fitting
DP 611-168	Dimensional Print – 871CR Conductivity/Resistivity Sensors with Tri-Clamp Fittings
DP 611-169	Dimensional Print – 871CR Insertion Sensors for use with Ball Valve Accessories
DP 611-170	Dimensional Print – Accessories for use with 871CR Conductivity/Resistivity Sensors
PL 611-019	Parts List – 871CR Conductivity/Resistivity Sensor

# Model Code

<u>Description</u>	<u>Model</u>
Conductivity/Resistivity Sensor	871CR
<b><u>Cell Factor/Selection</u></b>	
0.1 cm <sup>-1</sup> Conductivity/Resistivity Sensor with Class B 1000 Ω RTD	–A
0.1 cm <sup>-1</sup> Resistivity Sensor with Class A 1000 Ω RTD(a)	–B
10 cm <sup>-1</sup> Conductivity Sensor with Class B 1000 Ω RTD	–C
<b><u>Insulator</u></b>	
CPVC (b)	1
Virgin PVDF(c)	2
Virgin PEEK (c)	3
Glass-Filled PEEK (d)	4
Glass-Filled Noryl (d)	5
<b><u>Electrode Material</u></b>	
Graphite (d)	G
Monel (c)	M
Titanium (c)	T
<b><u>Insertion Length</u></b>	
Standard	1
4-inch	4
6-inch	6
<b><u>Sensor Mounting</u></b>	
Universal Bore Piece with 3/4 NPT CPVC Bushing (b) (e)	A
Universal Bore Piece with 3/4 NPT Virgin PVDF Bushing (c) (f)	B
Universal Bore Piece with 3/4 NPT Virgin PEEK Bushing (c) (g)	C
Universal Bore Piece with 3/4 NPT Glass-Filled PEEK Bushing (d) (h)	D
Universal Bore Piece with 3/4 NPT Glass-Filled Noryl Bushing (d) (i)	E
Insertion Sensor for use with 1 1/2-inch Tri-Clamp Fitting (j) (k)	F
Insertion Sensor for use with 1 1/4-inch PVDF Ball Valve Assembly (f) (l) (m) (n)	G
Insertion Sensor for use with 1-inch Stainless Steel Ball Valve Assembly (l) (m) (n) (o)	H
Universal Bore Piece (p)	J
Universal Bore Piece with Integral Conduit Fitting (p) (q)	K
<b><u>Temperature Compensation</u></b>	
1000 Ohm RTD	1

<u>Description</u>	<u>Model</u>
<b><u>Cable Selection</u></b>	
Standard Length 20 ft (6 m), Standard Temperature Cable	A
Standard Length 20 ft (6 m), High Temperature Cable	B
30 ft (9 m) Standard Temperature Cable	C
30 ft (9 m) High Temperature Cable	D
40 ft (12 m) Standard Temperature Cable	E
40 ft (12 m) High Temperature Cable	F
60 ft (18 m) Standard Temperature Cable	G
60 ft (18 m) High Temperature Cable	H
80 ft (24 m) Standard Temperature Cable	J
80 ft (24 m) High Temperature Cable	K
No Cable (Integral Connector on Sensor) (r) (s) (t) (u)	L
Variable Length Standard Temperature Cable (v)	M
Variable Length High Temperature Cable (v)	N
<b><u>Cable Termination</u></b>	
Cable with #6 Spade Lugs	1
Cable with Cord Connector (u) (w)	2
Integral Connector on Sensor (r) (s) (u) (x)	3
<b><u>Options</u></b>	
Calibration Cert/Cell Factor determined in Schneider Electric Pure Water Loop (a) (c) (y)	-R
Calibration Cert/Cell Factor/Cert NIST Traceable (Use for USP23)	-S
Example: 871CR-A1T1A1A1-S	

- a. Recommended for optimum resistivity measurement.
- b. A Cell Factor selection only.
- c. A and -B Cell Factor selection only.
- d. C Cell Factor selection only.
- e. Used with "1" insulator material only.
- f. Used with "2" insulator material only.
- g. Used with "3" insulator material only.
- h. Used with "4" insulator material only.
- i. Used with "5" insulator material only.
- j. Insertion lengths "4" and "6" only.
- k. -A and -B cell factors use titanium fittings; -C uses 316 SS fittings.
- l. Insertion lengths "1" and "4" only.
- m. Ball valve required for new installations.
- n. Insertion sensors must be selected with high temperature cable only.
- o. Electrode material "G" or "T" only.
- p. No mounting accessories included.
- q. Not available with cable selection "L."
- r. Not recommended for optimum resistivity accuracy.
- s. Not available with sensor mounting "G," "H," or "K."
- t. Cable Termination "3" only.
- u. Patch cord required.
- v. Variable length offered up to 100 ft (30 m) maximum.
- w. Not available with high temperature cable selections.
- x. Cable selection "L" only.
- y. Option -R is for use with virgin PVDF insulator sensors only. For this option with virgin PEEK insulators, contact Global Customer Support.

# Standard Specifications

Sensor Type	Electrode Contacting Conductivity or Resistivity Sensor
Cell Factor	0.1cm <sup>-1</sup> or 10 cm <sup>-1</sup> , as specified
Measurement Ranges	Per Table 1
Process Temperature/Pressure Ratings	Per Tables 4 - 11
Materials (Sensor Type -A and -B) Insulator Electrode O-Ring Bushing Tri-Clamp Fitting Ball Valve Shaft	CPVC, Virgin PVDF, Virgin PEEK Titanium, Monel EPDM, Teflon-Impregnated EPDM CPVC, Virgin PVDF, Virgin PEEK, Titanium Titanium, Stainless Steel Virgin PVDF, Stainless Steel
Materials (Sensor Type -C) Insulator Electrode O-Ring Bushing Tri-Clamp Fitting Ball Valve Shaft	Glass-Filled PEEK, Glass-Filled Noryl Graphite EPDM, Teflon-Impregnated EPDM Glass-Filled PEEK, Glass-Filled Noryl, Stainless Steel Stainless Steel Stainless Steel
Mass	0.5 kg (1.1 lb)
Cable Material and Temperature Rating Standard Temperature Cable High Temperature Cable	PVC-Insulated: Rated to 80°C (176°F) Teflon-insulated: Rated to 200°C (392°F)
Transportation and Storage Temperature Limits	-40° to +70°C
Cable Length Standard Other lengths	6 m (20 ft) 9 m (30 ft) 12 m (40 ft) 18 m (60 ft) 24 m (80 ft)
Electromagnetic Compatibility (EMC)	Complies with EMC Directive 89/336/EEC when its cable is connected through rigid metal conduit and connected to an 870ITCR Transmitter or 875CR Analyzer.
Product Safety Specifications	See Table 2.

*Table 1. Measurement Ranges with a Model 870ITCR Transmitter or a Model 875CR Analyzer*

Supported Measurement Ranges			
871CR Cell Factor	Unit of Measure	With Model 876CR, 870ITCR	With Model 875CR
		Upper Range Settings (a)	Upper Range Settings (a)
0.1 cm <sup>-1</sup>	MΩ•cm	2, 5, 10, 15, 20	0.1, 0.2, 0.5, 2, 5, 10, 20
	kΩ•cm	50, 100, 500, 1000, 5000	50, 100, 200, 500, 1000, 2000, 5000
	mS/m	0.2, 0.5, 1, 2, 5, 10, 20	0.1, 0.2, 0.5, 1, 2, 5, 10, 20
	μS/cm	1, 2, 5, 10, 20, 50, 100, 200	1, 2, 5, 10, 20, 50, 100, 200
10.0 cm <sup>-1</sup>	kΩ•cm	10, 50	10, 50
	mS/m	50, 100, 200, 500	10, 20, 50, 100, 200, 500, 1000, 2000
	S/m	0.2, 0.5, 1, 2	0.1, 0.2, 0.5, 1, 2
	μS/cm	200, 500, 1000, 2000, 5000	200, 500, 1000, 2000, 5000
	mS/cm	0.2, 0.5, 1, 2, 5, 10, 20	0.2, 0.5, 1, 2, 5, 10, 20

a. Absolute (without temperature compensation) measurements exceed the range setting by approximately five times.

**— NOTE —**

These sensors have been designed to meet the electrical safety descriptions listed in Table 2. For detailed information or status of testing laboratory approvals/certifications, contact Global Customer Support.

*Table 2. Product Safety Specifications*

Testing Laboratory, Types of Protection, and Area Classification	Application Conditions	Electrical Safety Design Code
<b>ATEX</b> Intrinsically Safe for II 1 G, EEx ia IIC, Zone 0	Connect to certified 870ITCR Transmitter or 875CR Analyzer per MI 611-208. Temperature Class T3 - T6.	CS-E/EAA
<b>CSA</b> Intrinsically Safe for Class I, Division 1, Groups A, B, C, and D; Class II, Division 1, Groups E, F, and G; Class III, Division 1 hazardous locations.	Connect to certified 870ITCR Transmitter or 875CR Analyzer per MI 611-206. Temperature Class T6.	CS-E/CAA
CSA nonincendive Class I, Division 2, Groups A, B, C, and D; Suitable for Class I, Division 2, Groups A, B, C, and D; Class II, Division 2, Groups F and G; Class III, Division 2 hazardous locations.	Connect to certified 870ITCR Transmitter or 875CR Analyzer per MI 611-206. Temperature Class T6. Class II, Division 2 and Class III, Division 2 are only applicable to sensor mounting selection “K”.	CS-E/CNN
<b>FM</b> Intrinsically Safe for Class 1, Division 1, Groups A, B, C, and D; Class II, Division 1 Groups E, F, and G. Class III, Division 1 hazardous locations.	Connect to certified 870ITCR Transmitter or 875CR Analyzer per MI 611-206. Temperature Class T6.	CS-E/FAA
<b>FM</b> nonincendive Class 1, Division 2, Groups A, B, C, and D; Class II, Division 2 Groups F and G, Class III, Division 2 hazardous locations.	Connect to certified 870ITCR Transmitter or 875CR Analyzer per MI 611-206. Temperature Class T6.	CS-E/FNN

## Sensor Identification

Sensor identification is in the form of a model number which is marked on a label attached to the sensor. For interpretation of the number, see “Model Code” on page 2. Verify that this is what is required for your application. Electrical certification (if ordered) is identified on a second label that is attached to the cable.

# Theory of Operation

871CR Sensors are contacting conductivity sensors used to measure conductivity or resistivity of process fluids. These measurement techniques are nonspecific; that is, they cannot distinguish one ion type from another. But this technique has been used, for example, to measure water purity and to analyze the binary mixtures of electrolytes.

Conductance (or its reciprocal, Resistance) is an electrical property of solutions that arises from the presence of electrically charged ions in electrolytes. When a conductance cell is placed in this solution and an electrical potential is applied across the electrodes, a current flows as the ions migrate; the cations to the positively charged anode and the anions to the negatively charged cathode. In practice, a small amplitude alternating voltage is applied to help prevent measurement errors due to electrolysis. The magnitude of the resulting alternating current flow is related to the number of charge carriers present and therefore, the concentration of the electrolyte may be inferred from the conductance measurement.

For ultrapure and pure water applications, a cell factor of  $0.1 \text{ cm}^{-1}$  is selected and measurements are usually expressed as resistivity in units of  $M\Omega \cdot \text{cm}$  or in conductivity units of  $\mu\text{S}/\text{cm}$ . Ultrapure water applications benefit from resistivity measurements because it more effectively resolves the range of interest. For more conductive solutions, a cell factor of  $10 \text{ cm}^{-1}$  is used and measurements are expressed in  $\text{mS}/\text{cm}$ . When cells are interfaced to Schneider Electric analyzers or transmitters, the effects of temperature on measurements can be compensated and a readout in appropriate units can be displayed.

*Figure 1. 871CR Sensors*

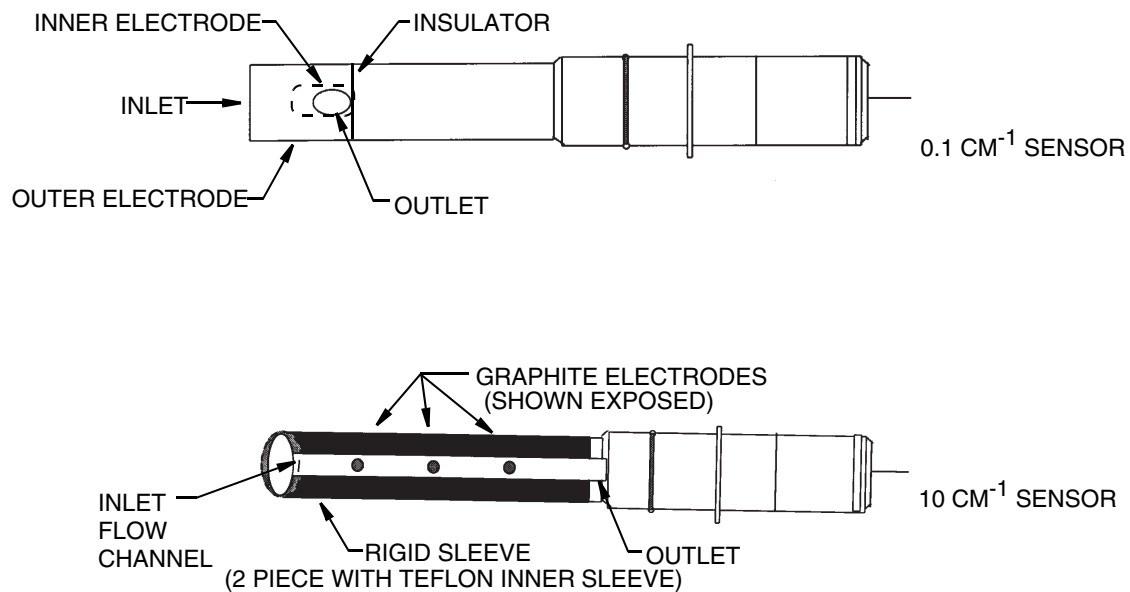

# 2. Installation

## General Installation Guidelines

Proper installation of the sensor is important for efficient and accurate operation. All installations should comply with standard and acceptable practices. Material of sensor and accessories must be compatible with temperature, pressure, and chemicals in the process.

For all applications and sensor configurations, mounting arrangements must be located so that:

1. Sample at the electrodes is representative of the solution.
2. Solution circulates actively and continuously past the electrodes area.
3. Flow velocity at the sensing area does not cause cavitation or cell damage.
4. Position and orientation of the sensor does not trap air bubbles within the electrode area. A horizontal installation is recommended. Flow should go into the bottom of the electrode and exit through holes in the outer body.
5. Deposits of sediment or other foreign material must not accumulate on the active electrodes or the insulator. Solids removal may be necessary as suspended solids can clog conductivity cells. Do not install sensors with cable end down.
6. If the cable is installed in metal conduit (recommended), either flexible conduit should be used or some other provision made for the removal of the sensor from the process.

— **NOTE** —

If installation requires removing the safety tag, reattach the tag to the sensor after the sensor has been installed. Failure to reinstall the tag could result in the loss of certification.

**▲ CAUTION**

**RISK of LOSING CERTIFICATION**

If installation requires removing the safety tag, reattach the tag to the sensor after the sensor has been installed.

**Failure to follow these instructions can cause injury or equipment damage**

# Installation of the Sensor

## Mounting Types A, B, C, D, E, K with Accessory Bushing

### *In-line Installation*

These sensors are considered in-line insertion sensors and have male threads for direct process piping insertion. The optimum installation uses a pipe tee with the sensor placed opposite the direction of flow and the discharge flowing upward. See Figure 2.

1. Install mounting bushing into process connection. Tighten per Table 3.

<b>⚠ WARNING</b>
<b>RISK OF EXCEEDING PRESSURE/TEMPERATURE RATING</b>
Do not exceed the pressure/temperature ratings of the material used.
<b>Failure to follow these instructions can result in death or serious injury.</b>

2. Place locking cap on cable and slide down toward shaft body.
3. Lubricate O-ring with small drop of deionized water.
4. Slide sensor shaft into mounting bushing until it stops.
5. Slide locking cap over sensor shaft and **hand tighten** onto bushing.

*Figure 2. In-line Installation of Sensor Mounting Types A Through E*

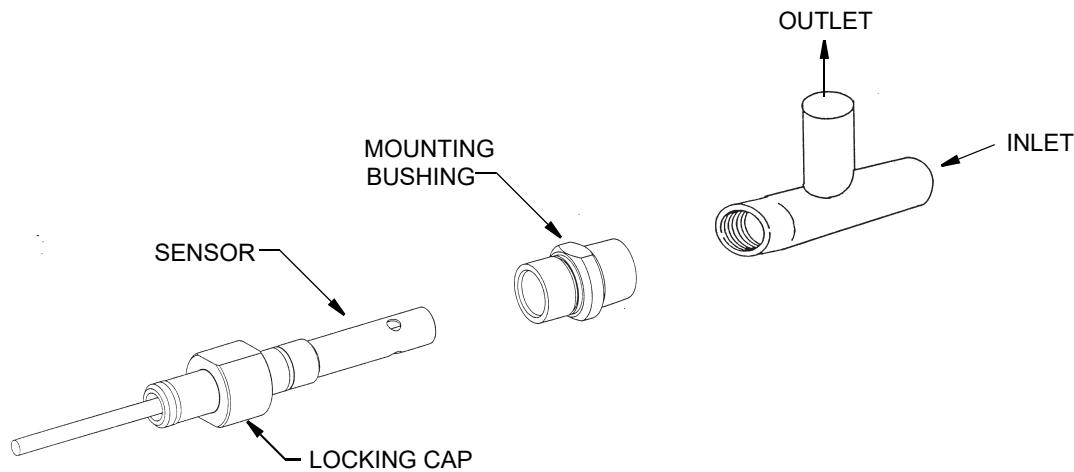



*Table 3. Torque Values for Mounting Bushings*

Bushing	Model Code	Bushing Material	Part Number	Torque
3/4 NPT	871CR-A 871CR-B	CPVC	BS809HR	24 in•lb (a) (b)
		Virgin PVDF	BS809ES	24 in•lb (a) (b)
		Virgin PEEK	BS809EQ	36 in•lb (a) (b)
		Titanium	BS809ER	(c)
	871CR-C	Glass-Filled Noryl	BS809HU	24 in•lb (a) (b)
		Glass-Filled PEEK	BS809DW	48 in•lb (a) (b)
316 SS		BS809DX	(c)	
1 NPT	871CR-A 871CR-B	CPVC	BS809HQ	37 in•lb (a) (b)
		Virgin PVDF	BS809EW	37 in•lb (a) (b)
		Virgin PEEK	BS809EU	55 in•lb (a) (b)
		Titanium	BS809EV	(c)
	871CR-C	Glass-Filled Noryl	BS809QV	37 in•lb (a) (b)
		Glass-Filled PEEK	BS809DY	65 in•lb (a) (b)
316 SS		BS809DZ	(c)	
ISO 7/1-R 1 1/2	871CR-A 871CR-B	CPVC	BS809FE	67 in•lb (a) (b)
		Virgin PVDF	BS809FD	67 in•lb (a) (b)
		Virgin PEEK	BS809FB	93 in•lb (a) (b)
		Titanium	BS809FC	(c)
	871CR-C	Glass-Filled Noryl	BS809QW	67 in•lb (a) (b)
		Glass-Filled PEEK	BS809EA	103 in•lb (a) (b)
316 SS		BS809EB	(c)	
ISO 7/1-R 2	871CR-A 871CR-B	CPVC	BS809FJ	88 in•lb (a) (b)
		Virgin PVDF	BS809FH	88 in•lb (a) (b)
		Virgin PEEK	BS809FF	120 in•lb (a) (b)
		Titanium	BS809FG	(c)
	871CR-C	Glass-Filled Noryl	BS809QX	88 in•lb (a) (b)
		Glass-Filled PEEK	BS809EC	130 in•lb (a) (b)
316 SS		BS809ED	(c)	

- a. Do not exceed two turns past “hand tight.”
- b. Torque specifications for plastic fittings assume a female fitting of the same material. If the female fitting is a different material, use the lower torque of the two materials.
- c. Tighten to three turns past “hand tight.”

**Table 4. Maximum Pressure/Temperature Ratings for Sensors in Bushing Mounts**

Bushing	Model Code	Bushing Material/ Insulator Material	Maximum Pressure/ Temperature Rating	Part Number
3/4 NPT	871CR-A 871CR-B	CPVC/CPVC	250 psig at 27 °C (80°F) (a) (b)	BS809HR
		Virgin PVDF/Virgin PVDF	250 psig at 24 °C (75°F) (b) (c)	BS809ES
		Virgin PEEK/Virgin PEEK	250 psig at 175 °C (350°F)(d) (b)	BS809EQ
		Titanium/Virgin PVDF	250 psig at 121 °C (250°F) (d)	BS809ER
		Titanium/Virgin PEEK	250 psig at 175 °C (350°F) (d)	
	871CR-C	Glass-Filled Noryl/Glass-Filled Noryl	150 psig at 121 °C (250°F) (b) (d)	BS809HU
		Glass-Filled PEEK/Glass-Filled PEEK	250 psig at 175 °C (350°F) (b) (d)	BS809DW
		316 SS/Glass-Filled Noryl	250 psig at 121 °C (250°F) (d)	BS809DX
		316 SS/Glass-Filled PEEK	250 psig at 175 °C (350°F) (d)	
	1 NPT	871CR-A 871CR-B	CPVC/CPVC	250 psig at 27 °C (80°F) (a)
Virgin PVDF/Virgin PVDF			250 psig at 24 °C (75°F) (c)	BS809EW
Virgin PEEK/Virgin PEEK			250 psig at 175 °C (350°F) (d)	BS809EU
Titanium/Virgin PVDF			250 psig at 121 °C (250°F) (d)	BS809EV
Titanium/Virgin PEEK			250 psig at 175 °C (350°F) (d)	
871CR-C		Glass-Filled Noryl/Glass-Filled Noryl	150 psig at 121 °C (250°F) (d)	BS809QV
		Glass-Filled PEEK/Glass-Filled PEEK	250 psig at 175 °C (350°F) (d)	BS809DY
		316 SS/Glass-Filled Noryl	250 psig at 121 °C (250°F) (d)	BS809DZ
		316 SS/Glass-Filled PEEK	250 psig at 175 °C (350°F) (d)	
ISO 7/1-R 1 1/2	871CR-A 871CR-B	CPVC/CPVC	250 psig at 27 °C (80°F) (a)	BS809FE
		Virgin PVDF/Virgin PVDF	250 psig at 24 °C (75°F) (c)	BS809FD
		Virgin PEEK/Virgin PEEK	250 psig at 175 °C (350°F) (d)	BS809FB
		Titanium/Virgin PVDF	250 psig at 121 °C (250°F) (d)	BS809FC
		Titanium/Virgin PEEK	250 psig at 175 °C (350°F) (d)	
	871CR-C	Glass-Filled Noryl/Glass-Filled Noryl	150 psig at 121 °C (250°F) (d)	BS809QW
		Glass-Filled PEEK/Glass-Filled PEEK	250 psig at 175 °C (350°F) (d)	BS809EA
		316 SS/Glass-Filled Noryl	250 psig at 121 °C (250°F) (d)	BS809EB
		316 SS/Glass-Filled PEEK	250 psig at 175 °C (350°F) (d)	
ISO 7/1-R 2	871CR-A 871CR-B	CPVC/CPVC	250 psig at 27 °C (80°F) (a)	BS809FJ
		Virgin PVDF/Virgin PVDF	250 psig at 24 °C (75°F) (c)	BS809FH
		Virgin PEEK/Virgin PEEK	250 psig at 175 °C (350°F) (d)	BS809FF
		Titanium/Virgin PVDF	250 psig at 121 °C (250°F) (d)	BS809FG
		Titanium/Virgin PEEK	250 psig at 175 °C (350°F) (d)	
	871CR-C	Glass-Filled Noryl/Glass-Filled Noryl	150 psig at 121 °C (250°F) (d)	BS809QX
		Glass-Filled PEEK/Glass-Filled PEEK	250 psig at 175 °C (350°F) (d)	BS809EC
		316 SS/Glass-Filled Noryl	250 psig at 121 °C (250°F) (d)	BS809ED
		316 SS/Glass-Filled PEEK	250 psig at 175 °C (350°F) (d)	

a. Linearly derated to 50 psig at 88 °C (190°F)

b. Included in model code selection of sensor.

c. Linearly derated to 42 psig at 121 °C (250°F)

d. Temperature rating is based on the use of high temperature cable. The use of standard cable limits the rating to 80 °C (176°F). The use of Cable Selection "L" or Cable Termination "3" limits the rating to 65 °C (149°F).

## Installation in Flow Chambers

Mounting these sensors in flow chambers provides a convenient way of mounting sensors in a system where a sample is provided by a small diameter sample line. The inlet and outlet ports have either 1/4 NPT or 1/2 NPT internal threads and connect to the system with user-supplied fittings. Flow chambers are available in Virgin PEEK, CPVC, 316 stainless steel, and Virgin PVDF. See Figure 3.

1. Mount the flow chamber to a rigid surface with U-bolts provided. The outlet should face upward. Allow 200 mm (8 in) minimum space for insertion and removal of the sensor from the flow chamber. The location must allow the sensor cable to reach the transmitter or junction box.
2. Install the (user-supplied) inlet and outlet fittings.
3. Install the mounting bushing into the flow cell. Tighten per Table 3.
4. Place the locking cap on the cable and slide down toward the shaft body.
5. Lubricate O-ring on sensor with small drop of deionized water.
6. Slide the sensor shaft into the mounting bushing until it stops.
7. Slide the locking cap over the sensor shaft and **hand tighten** it onto the bushing.

*Figure 3. Installation of Sensor Mounting Types A Through E in Flow Chamber*

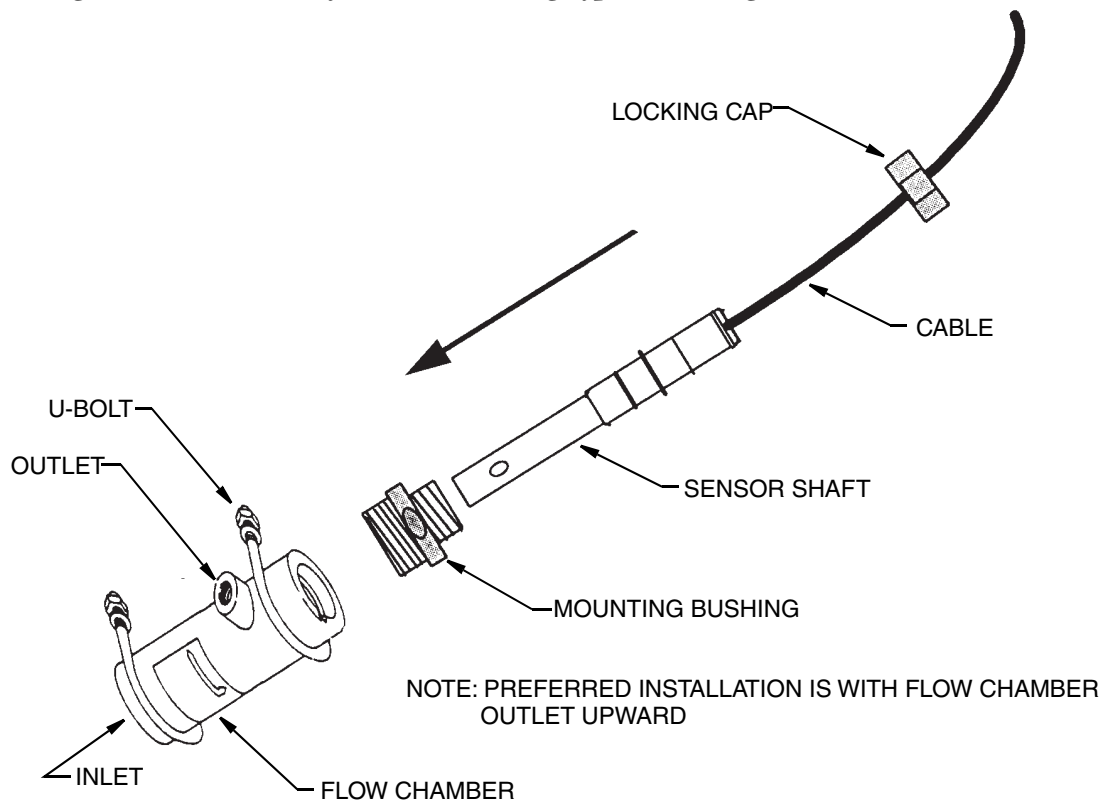

*Table 5. Maximum Pressure/Temperature Ratings for Flow Chambers*

Flow Chamber	Sensor Model Code	Material	Maximum Pressure/Temperature Rating	Part Number
3/4 NPT x 1/4 NPT Ports	871CR-A 871CR-B	PVC	60 psig at 50°C (122°F)	0051182
		Virgin PVDF	60 psig at 50°C (122°F)	BS805GR
	Virgin PEEK	250 psig at 175°C (350°F)(a)	BS809SG	
	316 SS	500 psig at 175°C (350°F)	0051180	
	871CR-C	316 SS	500 psig at 175°C (350°F)	0051180
1 NPT x 1/2 NPT Ports	871CR-A 871CR-B	CPVC	60 psig at 50°C (122°F)	BS809SF

a. Temperature rating is based on the use of high temperature cable. The use of standard cable limits the rating to 80°C (176°F).

Flow rates through flow chambers depend on the pressure drop across the inlet and outlet. Approximate flow rates for 20°C water at 60 psig line pressure are shown in Table 6.

*Table 6. Flow Rates*

Fitting	1.0 psi Pressure Drop	10.0 psi Pressure Drop
1/4 NPT	1.7 gal/min	5.2 gal/min
1/2 NPT	5.0 gal/min	15.0 gal/min

## Mounting Type F or Type J with Tri-Clamp Fitting

These sensors allow convenient installation in food, dairy, and pharmaceutical sanitary piping systems and use FDA compliant materials. However, they do not meet 3A clean-in-place requirements. The process-wetted surface of titanium and stainless steel Tri-Clamp fittings has an RA3 finish for models 871CR-A and 871CR-B and a 32 micron finish for model 871CR-C. Refer to Figure 4.

1. Place the locking cap on the cable and slide down toward the sensor shaft.
2. Slide the locking cap over the sensor shaft and hand tighten onto the threads.
3. Fit the sensor flange and gasket to the process flange and attach with a Tri-Clamp clamp. The process flange, gasket, and clamp are user-supplied.

Figure 4. Installation of Sensor Type F

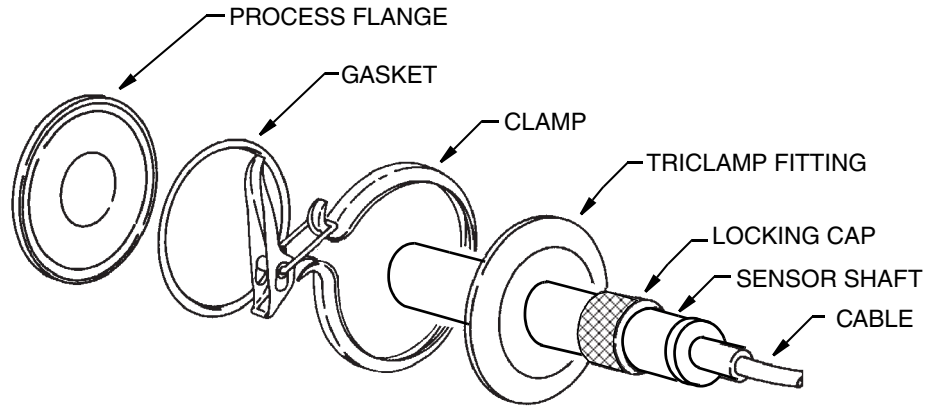

Table 7. Maximum Pressure/Temperature Ratings for Sensors in Tri-Clamp Mountings

Tri-Clamp Fitting	Model Code	Material	Part Number	Used With Insulator	Maximum Pressure/Temperature Rating(a)	
1 1/2 inch	871CR-A 871CR-B	Titanium	BS809AA(b)	Virgin PDVF	250 psig at 121 °C (250°F)	
				Virgin PEEK	250 psig at 175 °C (350°F)	
	871CR-C	316 SS	BS808KD	Virgin PDVF	250 psig at 121 °C (250°F)	
				Virgin PEEK	250 psig at 175 °C (350°F)	
				Glass-Filled PEEK	250 psig at 175 °C (350°F)	
				Glass-Filled Noryl	250 psig at 121 °C (250°F)	
2 inch	871CR-A 871CR-B	Titanium	BS809AB	Virgin PDVF	250 psig at 121 °C (250°F)	
				Virgin PEEK	250 psig at 175 °C (350°F)	
	871CR-C	316 SS	BS808KC	Virgin PDVF	250 psig at 121 °C (250°F)	
				Virgin PEEK	250 psig at 175 °C (350°F)	
				BS809DU	Glass-Filled PEEK	250 psig at 175 °C (350°F)
					Glass-Filled Noryl	250 psig at 121 °C (250°F)

- a. Temperature rating is based on the use of high temperature cable.  
 The use of standard cable limits the rating to 80°C (176°F).  
 The use of Cable Selection "L" or Cable Termination "3" limits the rating to 65°C (149°F)
- b. Included in model code selection of sensor.

## Mounting Types J or K in Schneider Electric Flanges

Type J and K sensors can be mounted in Schneider Electric 316 stainless steel accessory flanges with the use of locking caps.

1. Place the locking cap on the cable and slide it down toward the shaft body.
2. Slide the sensor shaft into the flange until it stops.
3. Slide the locking cap over the sensor shaft and **hand tighten** it onto the flange.

**Table 8. Pressure/Temperature Ratings for Sensors in Flange Mounts**

Flange Size	Flange Type	Maximum Pressure/Temperature Rating(a) (b)	Model Code	Part Number
2 inch	ANSI Class 150	230 psig at 38°C (100°F)	871CR-A 871CR-B	BS809LT
		230 psig at 38°C (100°F)	871CR-C	BS809UQ
2 1/2 inch	ANSI Class 150	230 psig at 38°C (100°F)	871CR-A 871CR-B	BS809LU
		230 psig at 38°C (100°F)	871CR-C	BS809UR
4 inch	ANSI Class 150	230 psig at 38°C (100°F)	871CR-A 871CR-B	BS809MN
		230 psig at 38°C (100°F)	871CR-C	BS809US
DN 50	DIN2501, PN 10	230 psig at 38°C (100°F)	871CR-A 871CR-B	BS809PC
		230 psig at 38°C (100°F)	871CR-C	BS809UT
DN 100	DIN 2501, PN 10	230 psig at 38°C (100°F)	871CR-A 871CR-B	BS809PD
		230 psig at 38°C (100°F)	871CR-C	BS809UU

- a. Linearly derated as follows:  
 198 psig at 88°C (190°F) with CPVC insulator  
 184 psig at 121°C (250°F) with Glass-filled Noryl or Virgin PVDF insulator  
 167 psig at 175°C (350 °F) with Glass-filled PEEK or Virgin PEEK insulator
- b. Temperature rating is based on the use of high temperature cable.  
 The use of standard cable limits the rating to 80°C (176°F).  
 The use of Cable Selection “L” or Cable Termination “3” limits the rating to 65°C (149°F)

## Installation of Insertion Sensor (Mounting Type G)

These sensors work with a 1 1/4-inch PVDF ball valve assembly, which is available from Schneider Electric. When the ball valve is closed, the sensor can be inserted or removed for cleaning, recalibration, or replacement without disturbing the process. For ball valve assembly specifications, refer to Table 9 and DP 611-170. For sensor dimensions, see DP 611-169. For pressure/temperature ratings of the mating sensor, see Table 10.

**Table 9. PVDF Ball Valve Assembly Specifications**

Parameter	Specification
Connection	1 1/4 NPT
Process Connection and Housing	Virgin PVDF
Ball Seat	PTFE
O-Ring Material	EPDM, Teflon-Impregnated EPDM
Pressure/Temperature Rating	100 psig at 60°C (140°F) derated to 60 psig at 121°C (250°F)

*Table 10. Pressure/Temperature Ratings for Ball Valve Insertion Sensor*

Sensor Model Code	Sensor Insulator Material	Sensor with Low Temperature Cable Pressure/Temperature Rating	Sensor with High Temperature Cable Pressure/Temperature Rating
871CR-A2T1G 871CR-B2T4G	Virgin PVDF	100 psig at 60°C (140°F) Linearly derated to 60 psi at 80°C (176°F)	100 psig at 60°C (140°F) Linearly derated to 60 psi at 121°C (250°F)

### *Installation of Ball Valve Assembly*

A ball valve assembly installation must meet mounting arrangements specified in “General Installation Guidelines” on page 7 as well as the following requirements:

- ◆ Install the ball valve assembly in a tee, boss, or flange that will accept a 1 1/4 NPT connection. The sensor should be positioned horizontally.
- ◆ Direct the flow of the solution (as much as possible) into the bottom opening of the sensor.
- ◆ Provide space for removal of the sensor in the ball valve assembly. Refer to DP 611-170.

### *Sensor Installation Procedure*

See Figure 5.

<b>⚠ WARNING</b>
<p><b>RISK OF EXCEEDING PRESSURE/TEMPERATURE RATING</b></p> <p>Do not exceed the assembly pressure/temperature limits.</p> <p>If the ball valve is installed in an application where the process stream is filled and pressurized, perform “Removal of the Insertion Sensor From the Ball Valve Assembly” on page 16 before proceeding.</p> <p><b>Failure to follow these instructions can result in death or serious injury.</b></p>

1. Close the ball valve by turning the handle clockwise (handle perpendicular to housing).
2. Remove the locking cap and the housing nut from the ball valve assembly.
3. Slide the insertion sensor shaft assembly into the ball valve housing until it contacts the closed ball valve.
4. Lubricate the seal assembly O-rings on the sensor shaft with distilled water. Do **not** use silicone grease.
5. Using a twisting motion, slide the seal assembly along the shaft until it seats into the end of the housing.

<b>▲ CAUTION</b>
<b>RISK OF OPERATION HAZARD</b>
Do not nick the O-Rings. Do not lubricate with silicone grease.
Failure to follow these instructions can result in injury.

*Figure 5. PVDF Ball Valve Assembly and Insertion Sensor Assembly*

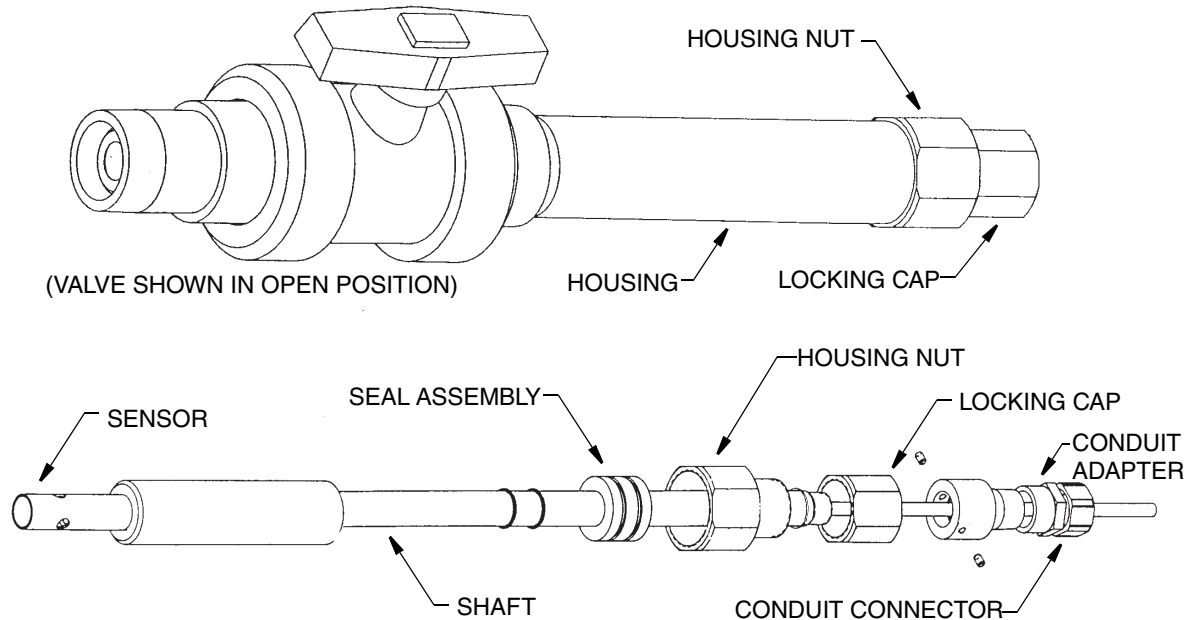

6. Slide the housing nut and the locking cap along the sensor cable to the shaft. Screw the housing nut onto the housing. Hand tighten it.
7. Open the valve by turning the handle counterclockwise (handle parallel to housing).
8. Insert the insertion sensor shaft assembly into the process until the locking cap meets the housing nut. Thread the locking cap onto the housing nut. Hand tighten it.
9. Slide the conduit adapter and the conduit connector along the sensor cable to the shaft. Thread the conduit adapter onto end of the shaft and tighten the set screws.
10. Thread the conduit connector onto the conduit adapter.

### *Removal of the Insertion Sensor From the Ball Valve Assembly*

1. Carefully loosen and detach the locking cap only. Do **not** loosen the housing nut.
2. Retract the shaft assembly as far as possible (until the sensor contacts the housing nut).
3. Turn the ball valve handle clockwise until the valve is completely closed (handle perpendicular to housing isolation chamber).
4. Loosen the housing nut slightly. If there is a continuous leak through the port on the housing nut, check to be sure the valve is completely closed. If the leak continues, the ball valve is not closing properly. The process line or tank may need to be emptied and depressurized.



5. Wait for the temperature to reduce to an acceptable level.
6. Remove the housing nut and withdraw the insertion sensor shaft assembly from the housing isolation chamber.

## Installation of Insertion Sensor (Mounting Type H)

These sensors work with a 1 NPT stainless steel ball valve assembly, which is available from Schneider Electric. When the ball valve is installed, the sensor can be inserted or removed without disturbing the process. For ball valve assembly specifications, refer to Table 11 and DP 611-170. For sensor dimensions, see DP 611-169. For pressure/temperature ratings of the mating sensor, see Table 12.

*Table 11. Stainless Steel Ball Valve Assembly Specifications*

Parameter	Specification
Connection	1 NPT
Ball Valve Material	316 SS
Shock Absorber Material	ptfe
O-Ring Material	Viton
Temperature/Pressure Rating	500 psig at 143°C (290°F) Linearly derated to 275 psig at 175°C (350°F)

*Table 12. Pressure/Temperature Ratings for Ball Valve Insertion Sensor*

Sensor Model Code	Sensor Insulator Material	Sensor with Low Temperature Cable Pressure/Temperature Rating	Sensor with High Temperature Cable Pressure/Temperature Rating
871CR-A1T1H 871CR-B1T1H 871CR-A1T4H 871CR-B1T4H	CPVC	250 psig at 82°C (180°F)	Not Available
871CR-A2T1H 871CR-B2T1H 871CR-A2T4H 871CR-B2T4H	Virgin PVDF	250 psig at 80°C (176°F)	250 psig at 121°C (250°F)
871CR-A3T1H 871CR-B3T1H 871CR-A3T4H 871CR-B3T4H	Virgin PEEK	500 psig at 80°C (176°F)	500 psig at 143°C (290°F)
871CR-C4T1H 871CR-C4T4H	Glass-Filled PEEK	500 psig at 105°C (221°F)	500 psig at 175°C (350°F)
871CR-C5T1H 871CR-C5T4H	Glass-Filled Noryl	500 psig at 105°C (221°F)	250 psig at 175°C (350°F)

## Installation of the Ball Valve Assembly

A ball valve assembly installation must meet mounting arrangements specified in “General Installation Guidelines” on page 7 as well as the following requirements:

- ◆ Install the ball valve assembly in a tee, boss, or flange that will accept a 1 NPT connection. The sensor should be positioned horizontally.
- ◆ Direct the flow of the solution (as much as possible) into the bottom opening of the sensor.
- ◆ Provide space for removal of the sensor in the ball valve assembly. Refer to DP 611-170.

## Sensor Installation Procedure

See Figure 6.

*Figure 6. Insertion of Sensor Mounting H into the Stainless Steel Ball Valve*

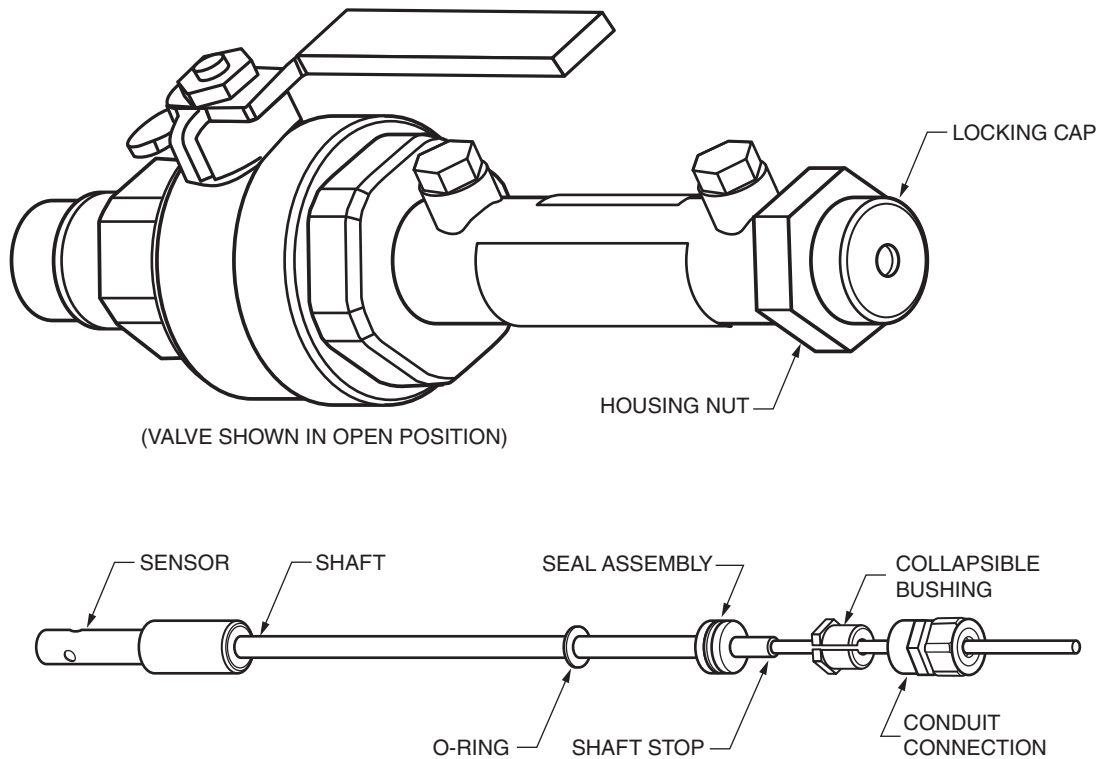

1. Close the ball valve by turning the handle clockwise (handle perpendicular to housing).
2. Remove the locking cap and the housing nut from the ball valve housing.
3. Slide the housing nut and the locking cap (from the ball valve housing) onto the insertion sensor cable.
4. Lightly lubricate the O-ring on the seal assembly with silicone grease.
5. Slide the insertion sensor shaft assembly into the ball valve housing until it contacts the closed ball valve.

6. Using a twisting motion, slide the seal assembly along the shaft until it seats into the end of the housing.
7. Slide the housing nut and the locking cap along the sensor cable to the shaft. Screw the housing nut onto the housing. Hand tighten it.
8. Open the valve by turning the handle counterclockwise (handle parallel to housing).
9. Insert the insertion sensor shaft assembly into the process until the shaft stop (chamfer on shaft) lines up with the housing nut. Thread the locking cap onto the housing nut. Hand tighten it.
10. Slide the collapsible bushing down the sensor cable, onto the shaft, and seat it against the locking cap.
11. Assemble the conduit connection assembly onto the collapsible bushing and attach the bushing onto the shaft of the insertion sensor assembly.

### *Removal of the Insertion Sensor from the Ball Valve Assembly*

1. Carefully loosen and detach the locking cap only. Do **not** loosen housing nut.
2. Retract the shaft assembly as far as possible (until the sensor contacts the housing nut).
3. Turn the ball valve handle clockwise until the valve is completely closed (handle perpendicular to housing isolation chamber).
4. Loosen the housing nut slightly. If there is a continuous leak through the port on the housing nut, check to be sure the valve is completely closed. If the leak continues, the ball valve is not closing properly. The process line or tank may need to be emptied and depressurized.
5. Wait for the temperature to reduce to an acceptable level.
6. Remove the housing nut and withdraw the insertion sensor shaft assembly from the housing isolation chamber.

# Sensor Wiring

## Connecting to an 870ITCR Transmitter

*Table 13. Wiring Connections at 870ITCR Transmitter*

Wire Color	Wire Number	Terminal Connection	Signal Description
Bare	1	1	Ground (Outer Electrode)
White(a) (Thick)	2	2	Drive (Inner Electrode)
Bare*	2A	2A	Shield
White	3	3	RTD Measurement
Black	4	4	RTD Return
Red	5	5	RTD 3-Wire Return

a. Inside Brown Jacket on standard temperature cable and inside gray jacket on high temperature cable

---

### NOTE

1. Make sure the jumper straps connect terminals 1 to 1B and 1E to 2.
  2. If you are using absolute measurements and not wiring a temperature measuring device, connect terminals 3, 4, and 5 to each other to minimize noise.
  3. Wire numbers and terminal connections are the same when a patch cord is used.
-

## Connecting to an 875CR Analyzer

*Table 14. Wiring Connections at 875CR Analyzer*

Wire Color	Wire Number	Terminal Connection	Signal Description
Bare	1	1	Ground (Outer Electrode)
White(a)(Thick)	2	2	Drive (Inner Electrode)
Bare*	2A	2A	Shield
White	3	3	ATC Return
Black	4	4	ATC Drive
Red	5	5	RTD Cable Length Comp

a. Inside Brown Jacket on standard temperature cable and inside gray jacket on high temperature cable

---

**NOTE**

Wire numbers and terminal connections are the same when a patch cord is used.

---



# 3. Calibration

Schneider Electric conductivity/resistivity sensors are manufactured under strict guidelines for quality and uniformity. The 0.1 cm<sup>-1</sup> cell factor sensors are manufactured to be within 1% of their nominal cell factor; the 10 cm<sup>-1</sup> sensors to be within 5%. Even with the stringent specifications of our manufacturing procedures, offsets from theoretical values are possible. In many applications, the sensor can be connected to the analyzer and used without further calibration. For the best possible system accuracy, the proper sensor must be selected and measurements of standard conductivity solution performed to calibrate the measurement system.

## Selection of Proper Sensor

The proper sensor selection helps ensure optimum measurements. Two cell factors are available through the 871CR model selection: 0.1 and 10 cm<sup>-1</sup>. Choosing the correct cell factor is dictated by the measurement range and the measurement instrumentation being used. Midrange conductivity measurements (full measurement ranges greater than 200 μS/cm) utilize a 10 cm<sup>-1</sup> cell factor, a model 871CR-C sensor. Low conductivity and resistivity measurements (full measurement ranges of 200 μS/cm or less) utilize a 0.1 cm<sup>-1</sup> cell factor, models 871CR-A and 871CR-B sensors. The 871CR-A incorporates a Class B 1000 Ω RTD; the 871CR-B, uses a Class A 1000 Ω RTD, thus providing the most accurate measurement and temperature compensation for resistivity.

Actual cell factor (CF) determinations are available for the 0.1 cm<sup>-1</sup> cell factor sensors. Two types of factory cell factor calibrations are available. If no option or the -S option is selected, the sensor is calibrated and tagged as a conductivity sensor using a NIST traceable method with a ±0.0031 accuracy. The -S option includes a certificate of calibration with the sensor packaging. If you select the 871CR-B sensor with the -R option, the cell factor (CF) is determined in an ultrapure water loop at Schneider Electric. The sensor is tagged with this information and a certificate of calibration is included with this option. The accuracy of this method is ±0.000101.

For precise resistivity measurements, the 871CR-B sensor with the -R calibration option is suggested. Low level conductivity measurements (to 200 μS/cm) may utilize the 871CR-A with the -S calibration option or no option. Midrange conductivity measurements (>200 μS/cm to 20 mS/cm) require an 871CR-C sensor. High range conductivity measurements are also available through Schneider Electric utilizing electrodeless conductivity technology. Contact Global Customer Support for information.

## Calibrations in Ultrapure and Pure Water Applications (0.1 cm<sup>-1</sup> Cell Factor)

As calibration standards and controls are not readily available for precise temperature and ultrapure and pure water measurement ranges, Schneider Electric suggests using the factory determined cell factor (CF) and temperature cell factor (tCF) for system calibration. Both the CF and tCF are provided on the cable tags. Using these factory determined cell factors rather than nominal cell factors provides greater accuracy.

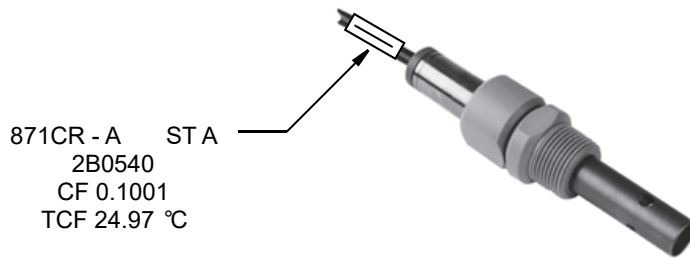
*Figure 7. Sensor Identification*

When the sensor is connected directly to an 870ITCR Transmitter or 875CR Analyzer, the factory-determined CF and tCF for the individual sensor can be entered at the pure water option of the transmitter/analyzer calibration procedure. MI 611-216 shows how to enter these values in an 870ITCR Transmitter and MI 611-222 in an 875CR Analyzer. Sensors can be sent back to the factory for periodic cleaning, calibration, and certification. Contact Global Customer Support for details.

## Calibrations for Conductivity Ranges above 50 $\mu\text{S}/\text{cm}$ (0.1 and 10 $\text{cm}^{-1}$ Cell Factor)

Schneider Electric suggests solution calibration to optimize measurement accuracy. Calibration should be performed after sensor cleanings and every time the rigid sheath is removed from the 10  $\text{cm}^{-1}$  cell factor sensor for cleaning or inspection. It is also suggested when patch cables or junction boxes with extension cables are used.

Before the calibration is performed for the first time, the temperature measurement of the solution should be verified and the value in the 870ITCR Transmitter or 875CR Analyzer adjusted if required. This is accomplished by immersing an accurate thermometer and the sensor into the solution. Allow the sensor to reach thermal equilibrium with the solution before making any adjustments.

All applications using moderate conductivity measurements may be standardized by performing a single-point or 2-point calibration. See MI 611-216 for details when using an 870ITCR Transmitter and MI 611-222 for details when using an 875CR Analyzer. Commercial conductivity calibration solutions are available from many scientific supply houses. Directions for the preparation of several potassium chloride solutions are found below. Please note that these solutions are not buffered. Contamination from rinse water or evaporation changes the solution's value.

## How to Prepare Conductivity Standards

The following is referenced from ASTM Method D 1125.



*Table 15. Preparation of Conductivity Standards*

Standard Concentration (approximate)	How to Prepare	Conductivity at 25°C
0.1 N	Dissolve 7.4365 g of KCl in 1 L of DI water	12.85 mS/cm
0.01N	Dissolve 0.7440 g of KCl in 1 L of DI water	1.409 mS/cm
0.001 N	Dilute 100 mL of 0.01 N KCl standard to 1 L with DI water	146.9 $\mu$ S/cm

ACS grade potassium chloride, with an assay purity of 100% $\pm$ 0.1%, should be used. Dry this salt in an oven at 150°C for two hours and allow it to cool in a desiccator before preparing the conductivity standards. DI water should have a conductivity less than 1.5  $\mu$ S/cm. Allow reagent water to equilibrate to laboratory atmosphere, determined when the conductivity of the water remains constant. Follow good laboratory practice in preparing these solutions using appropriate volumetric glassware and an analytical balance.



# 4. Maintenance

## Process Temperature versus Temperature Sensor Resistance

Table 16 lists the process temperature values and the corresponding resistance values of the RTD. Resistance of the RTD should approximate the value given in Table 16 for the appropriate temperature (see applicable analyzer or transmitter MI). If it does not, replace the sensor.

*Table 16. Process Temperature vs. Temperature Sensor Resistance*

Process Temperature		RTD Resistance
°C	°F	$\Omega \pm 0.1\%$
-5	+20	980.4
0	32	1000.0
10	50	1039.0
20	68	1077.9
25	77	1097.3
30	86	1116.7
40	104	1155.4
50	122	1194.0
60	140	1232.4
70	158	1270.7
80	176	1308.9
90	194	1347.0
100	212	1385.0
105	225	1403.9
110	230	1422.8
120	248	1460.6
130	266	1498.2
160	320	1610.4

## Electrode Inspection

The accuracy of the sensor may be affected by deposits from the process liquid. Therefore, the sensor may require cleaning on a scheduled basis.

Inspect the electrodes as needed. The electrode should be cleaned periodically.

## Cleaning the Electrode

Deposits on the electrode (immersion portion of the sensor, Figure 8) can seriously affect the sensor's accuracy.

A tentative schedule for cleaning the electrode should be established. The time interval between cleanings can be increased or decreased (depending on the nature of process liquid or the difference between conductivity/resistivity readings before and after cleaning).

A sensor may be returned to Schneider Electric for cleaning and recertification. Contact Global Customer Support or your local Schneider Electric representative to request this service.

Alternately, you may use the following procedure:

1. Remove the sensor from the process.
2. If deposits are visible, flush the sensor by flowing deionized water through the electrode with a forceful jet.
3. Gently move the immersion portion of the sensor in a solution of mild detergent or a dilute solution of a suitable acid or base as appropriate until the deposits are loosened. The choice of cleaning solution depends on the nature of the process liquid and deposits. Generally use the mildest cleaner capable of dissolving the deposit.
4. Use a soft brush (for example, a toothbrush) to wipe away the **external** deposits.
5. Repeat Steps 2-4 until the sensor is clean.
6. With a sensor having a cell factor of  $10 \text{ cm}^{-1}$ , remove the sleeve assembly by sliding it off (see Figure 8). Clean both sides of the sleeve.
7. Sensors with a  $0.1 \text{ cm}^{-1}$  cell factor are made with a nonremovable outer electrode. Care should be taken to help prevent skin oils from contacting either the inner or outer electrodes. Rough handling of these components could alter the cell factors.
8. Rinse the sensor thoroughly in distilled water, reinstall the plastic sleeve (if removed), and return the sensor to the process.

*Figure 8. Immersion Portion of Sensors*

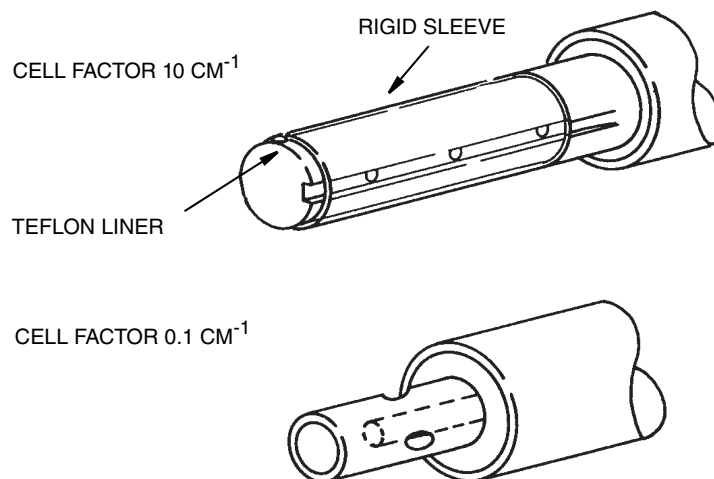

## Replacing the Sensor in Sensor Mounting Type G

1. Remove the snap ring at the shaft-retainer interface.
2. Unscrew the retainer and remove from the sensor.
3. Remove the sensor cable from the shaft.
4. Replace the O-ring at the end of the shaft.
5. Install the new cable in the shaft.
6. Replace the retainer and snap ring.

*Figure 9. Replacing the Sensor in the Sensor Mounting Type G*

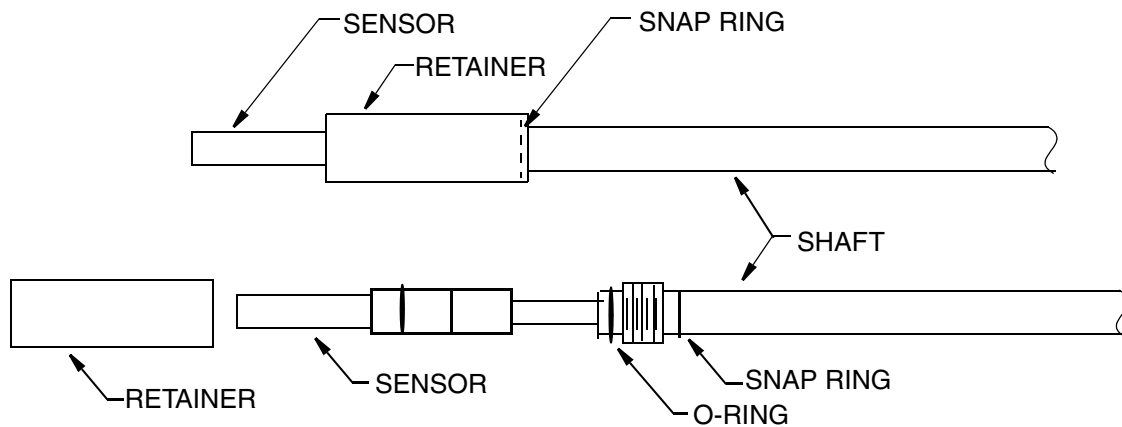

**ISSUE DATES**

OCT 1998  
DEC 2005  
JUN 2006  
MAY 2018

Vertical lines to the right of text or illustrations indicate areas changed at last issue date.

Schneider Electric Systems USA, Inc. Global Customer Support  
38 Neponset Avenue Inside U.S.: 1-866-746-6477  
Foxboro, MA 02035 Outside U.S.: 1-508-549-2424  
United States of America <https://pasupport.schneider-electric.com>  
<http://www.schneider-electric.com>

Copyright 1998-2018 Schneider Electric Systems USA, Inc. All rights reserved.

Schneider Electric is a trademark of Schneider Electric Systems USA, Inc., its subsidiaries, and affiliates. All other trademarks are the property of their respective owners.

