

Absolute, Gauge, and Differential Pressure Transmitters

HART Communication and SIL 2

Master Instruction

MI 020-611

Release date December 4, 2019



Legal Information

The Schneider Electric brand and any trademarks of Schneider Electric SE and its subsidiaries referred to in this guide are the property of Schneider Electric SE or its subsidiaries. All other brands may be trademarks of their respective owners.

This guide and its content are protected under applicable copyright laws and furnished for informational use only. No part of this guide may be reproduced or transmitted in any form or by any means (electronic, mechanical, photocopying, recording, or otherwise), for any purpose, without the prior written permission of Schneider Electric.

Schneider Electric does not grant any right or license for commercial use of the guide or its content, except for a non-exclusive and personal license to consult it on an "as is" basis. Schneider Electric products and equipment should be installed, operated, serviced, and maintained only by qualified personnel.

As standards, specifications, and designs change from time to time, information contained in this guide may be subject to change without notice.

To the extent permitted by applicable law, no responsibility or liability is assumed by Schneider Electric and its subsidiaries for any errors or omissions in the informational content of this material or consequences arising out of or resulting from the use of the information contained herein.

Important Information

Read these instructions carefully and look at the equipment to become familiar with the device before trying to install, operate, service, or maintain it. The following special messages may appear throughout this manual or on the equipment to warn of potential hazards or to call attention to information that clarifies or simplifies a procedure.



The addition of either symbol to a “Danger” or “Warning” safety label indicates that an electrical hazard exists which will result in personal injury if the instructions are not followed.



This is the safety alert symbol. It is used to alert you to potential personal injury hazards. Obey all safety messages that accompany this symbol to avoid possible injury or death.

⚠ DANGER

DANGER indicates a hazardous situation which, if not avoided, **will result in** death or serious injury.

Failure to follow these instructions will result in death or serious injury.

⚠ WARNING

WARNING indicates a hazardous situation which, if not avoided, **could result in** death or serious injury.

⚠ CAUTION

CAUTION indicates a hazardous situation which, if not avoided, **could result in** minor or moderate injury.

NOTICE

NOTICE is used to address practices not related to physical injury.

Please Note

Electrical equipment should be installed, operated, and maintained only by qualified personnel. No responsibility is assumed by Schneider Electric for any consequences arising out of the use of this material.

A qualified person is one who has skills and knowledge related to the construction, installation, and operation of electrical equipment and has received safety training to recognize and avoid the hazards involved.

Table of Contents

Introduction.....	9
Reference Documents.....	9
Transmitter Identification.....	10
Standard Specifications.....	11
Operative Limits.....	11
Span and Range Limits.....	12
Maximum Static, Overrange, and Proof Pressure Ratings.....	14
Elevated Zero and Suppressed Zero.....	15
Sensor Fill Fluid.....	15
Minimum Allowable Absolute Pressure vs Process Temperature.....	15
Mounting Position.....	16
Approximate Mass.....	16
Process Connections.....	16
Process Wetted Materials.....	17
Reference (Low) Pressure Side Materials.....	17
Electrical Connections.....	17
Switching and Indirect Lightning Transients.....	17
Field Wiring Reversal.....	17
Adjustable Damping.....	18
Output Signal.....	18
External Zero Adjustment.....	18
Supply Voltage.....	18
Electrical Ground Connections.....	18
HART Communicator Connection Points.....	18
Test Points.....	18
Remote Communication.....	19
4 to 20 mA Output.....	19
Agency Certifications.....	19
Electrical Certifications.....	20
Installation.....	22
Transmitter Mounting.....	22
Sanitary Process Connections.....	25
Pulp and Paper Process Connections.....	27
Manifold Mounting of Differential Pressure Transmitters.....	29
Mounting a Differential Pressure Transmitter Using a Bracket.....	30
Typical Piping for Absolute and Gauge Pressure Transmitters.....	35
Piping for Direct Connect AP and GP Transmitters.....	35
Piping for Biplanar AP and GP Transmitters.....	36
Additional Steps for Differential Pressure Transmitter Installation.....	37
Venting and Draining.....	37
Installation of Flow Measurement Piping.....	39
Filling the System with Seal Liquid.....	41
Positioning the Housing.....	42
Positioning the Display.....	42
Setting the Write Protect Jumper.....	43

Cover Locks	44
Wiring	44
Accessing Transmitter Field Terminals	44
Wiring the Transmitter to a Control Loop.....	45
Multidrop Communication	48
Connecting the Transmitter to a Schneider Electric Distributed Control System	49
Putting a Differential Pressure Transmitter into Operation.....	49
Taking a Differential Pressure Transmitter out of Operation	49
Operation with the Local Display.....	51
Entering Strings and Numeric Values.....	52
Reranging	53
Viewing the Database.....	54
Testing the Display	57
Messages.....	59
Configuration.....	60
Configuration Using the Optional Local Display	60
Messages	72
Configuration Using a PC50.....	73
Configuration Using a HART Communicator.....	73
Calibration	74
FoxCal™ Multiple Calibration Technology	74
Enabling and Disabling FoxCal™	74
One-Point Calibration at LRV	75
Two-Point Field Calibration	75
Calibration Notes	75
Calibration Setup	77
Electronic Calibration Equipment	78
Field Calibration Setup.....	78
Bench Calibration Setup	80
Calibration Using the Optional Local Display	82
Messages	85
Using the External Zero Button.....	86
Zero Adjustment for Transmitters with the Optional Display.....	87
Zero Adjustment for Transmitters without the Optional Display	87
Calibration Using a PC50.....	88
Calibration Using a HART Communicator.....	88
Using the HART Communicator.....	89
Connecting the Communicator to the Transmitter	89
Operation	89
Valid Characters for the HART Communicator.....	89
Online Configuration.....	89
Calibration	93
PV Rerange	93
PV Offset	94
PV Flow URV	94
SV Rerange	94

Pressure Calibration	94
Zero Trim	95
Scaled D/A Trim	95
Time in Service Meter	95
Enabling and Disabling the FoxCal™ Calibration Feature	96
Maintenance	97
Parts Replacement.....	97
Replacing the Terminal Block Assembly	97
Replacing the Vent Plug.....	98
Adding the Optional Display	99
Rotating Process Covers for Venting.....	99
Dimensions	101
Direct Connect AP and Direct Connect GP Transmitters.....	101
Biplanar AP and Biplanar GP Transmitters	105
DP Transmitters	108
Parts	114
Model Codes	114
Absolute and Gauge Pressure Transmitters.....	114
Differential Pressure Transmitters.....	126
Transmitter Parts.....	133
Parts for Direct Connect AP and GP Transmitters	133
Parts for Biplanar AP and GP Transmitters	135
Parts for DP Transmitters	140
Housing Covers.....	147
Optional Selections	148
Mounting Bracket Sets for Direct Connect Transmitters	148
Mounting Bracket Sets for DP and Biplanar Transmitters	150
Vent Screw (Option -V1).....	152
Block and Bleed Valve (Options -V2, -V3, and -V4).....	152
Adapter Plates (Options -P1 to -P8) for Direct Mounting to Coplanar Manifolds.....	153
LCD Indicator (Digital Display) Assembly (Option -L1)	154
Conduit Connections (Options -A1 and -A3)	154
Custody Transfer Lock and Seal (Option -Z2)	155
Ermeto Connectors (Options -E3 and -E4).....	155
Metric Process Connection (Option -R)	156
Recommended Spare Parts.....	156
Appendix A: Functional Safety Information	160
Scope	160
Acronyms and Definitions	160
SIL 2 Reference Documents	161
Safety Specifications	162
Product Identification	162
Safety Related Parameters	163
Reliability Data	164
Certification Data.....	167
Personnel.....	167

Installation	167
Configuration and Setup	167
Startup	169
Preventive Maintenance	169
Periodic Proof Testing	169
Periodic Inspection	170
Periodic Parts Replacement	170
Firmware Updates	170
Other Preventive Maintenance	171
Required Maintenance Documentation	171
Fault Handling	171
How to Detect a Fault.....	171
Repair and Replacement	171
Shutdown	171
Tools	172
Tools Necessary for Maintenance	172
Tools Necessary for Revalidation	172
Procedures for Tools Maintenance	172

Introduction

These pressure transmitters measure pressure by applying the pressure to a piezoresistive silicon microsensors within the sensor assembly. The microsensors convert the pressure to a change in resistance, and the resistance change is converted to a signal that is proportional to the pressure.

- Absolute pressure transmitters measure pressure relative to vacuum. Gauge pressure transmitters measure pressure relative to ambient air pressure. Both absolute and gauge transmitters are used in a wide variety of oil, gas, water and industrial applications.
- Differential pressure transmitters measure the difference between *two* pressures applied to opposite sides of the sensor. The output signal is proportional to either the differential pressure or its square root.

Differential pressure transmitters are often used for measuring fluid flow rates across a primary device such as an orifice plate, but can also be used for other types of differential pressure measurements such as liquid level, interface level, or density measurements.

The 4 to 20 mA or digital measurement signals are transmitted to remote receivers over the same two wires that supply power to the transmitter electronics. These wires also carry two-way data signals between the transmitter and remote communication devices. The transmitter allows direct analog connection to common receivers while still providing full intelligent transmitter digital communication using a HART Communicator.

The pressure transmitter can be supplied with direct-connect or remote pressure seals to isolate the measuring element from corrosive or viscous fluids.

Reference Documents

Document	Description
Instructions	
MI 020-611	Absolute, Gauge, and Differential Pressure Transmitters with HART Communication and SIL 2
MI 020-612	Absolute, Gauge, and Differential Pressure Transmitters with FOUNDATION Fieldbus Communication
MI 020-613	Absolute, Gauge, and Differential Pressure Transmitters with Low Power
MI 020-328	Bubble Type Installation for Liquid Level
MI 020-329	High Accuracy Flow Measurement
MI 020-369	Pressure Seals
MI 020-501	PC50 Intelligent Field Device Tool (Installation and Parts List)
MI 020-520	PC50 Intelligent Field Device Tool with Advanced DTM Library
MI 020-543	FM/CSA Safety Information
MI 020-544	ATEX/IECEX Safety Information
MI 022-138	Bypass Manifolds - Installation and Maintenance
MI 022-335	Model CO Compact Orifice
Dimensional Prints	
DP 020-342	PSFLT Pressure Seals
DP 020-343	PSFPS and PSFES Pressure Seals
DP 020-345	PSFAR Pressure Seals

Document	Description
DP 020-346	PSFAD Pressure Seals
DP 020-347	PSTAR Pressure Seals
DP 020-348	PSTAD Pressure Seals
DP 020-349	PSISR Pressure Seals
DP 020-350	PSISD Pressure Seals
DP 020-351	PSSCR Pressure Seals
DP 020-353	PSSCT Pressure Seals
DP 020-354	PSSSR Pressure Seals
DP 020-355	PSSST Pressure Seals
DP 020-357	PSFFD Pressure Seals
DP 022-335	Model CO Compact Orifice
Parts List	
PL 006-172	Model CO Compact Orifice
Technical Information	
TI 1-50a	Liquid Density Measurement
TI 001-051	Liquid Interface Measurement
TI 001-052	Liquid Level Measurement
TI 37-75b	Transmitter Material Selection Guide
TI 037-097	Process Sealing of Pressure Transmitters for Use in Class I, Zone 0, 1, and 2 Hazardous Locations

Transmitter Identification

The diagram shows a sample transmitter data plate. This example is for an IGP10S transmitter; the details may be slightly different for other transmitter models.

- For a complete explanation of the model code, refer to *Model Codes, page 114*.
- The firmware version is identified on the top line of the display when you select **VIEW DB** in the top level menu (*Top Level Menu, page 52*).

Figure 1 - Data Plate Contents

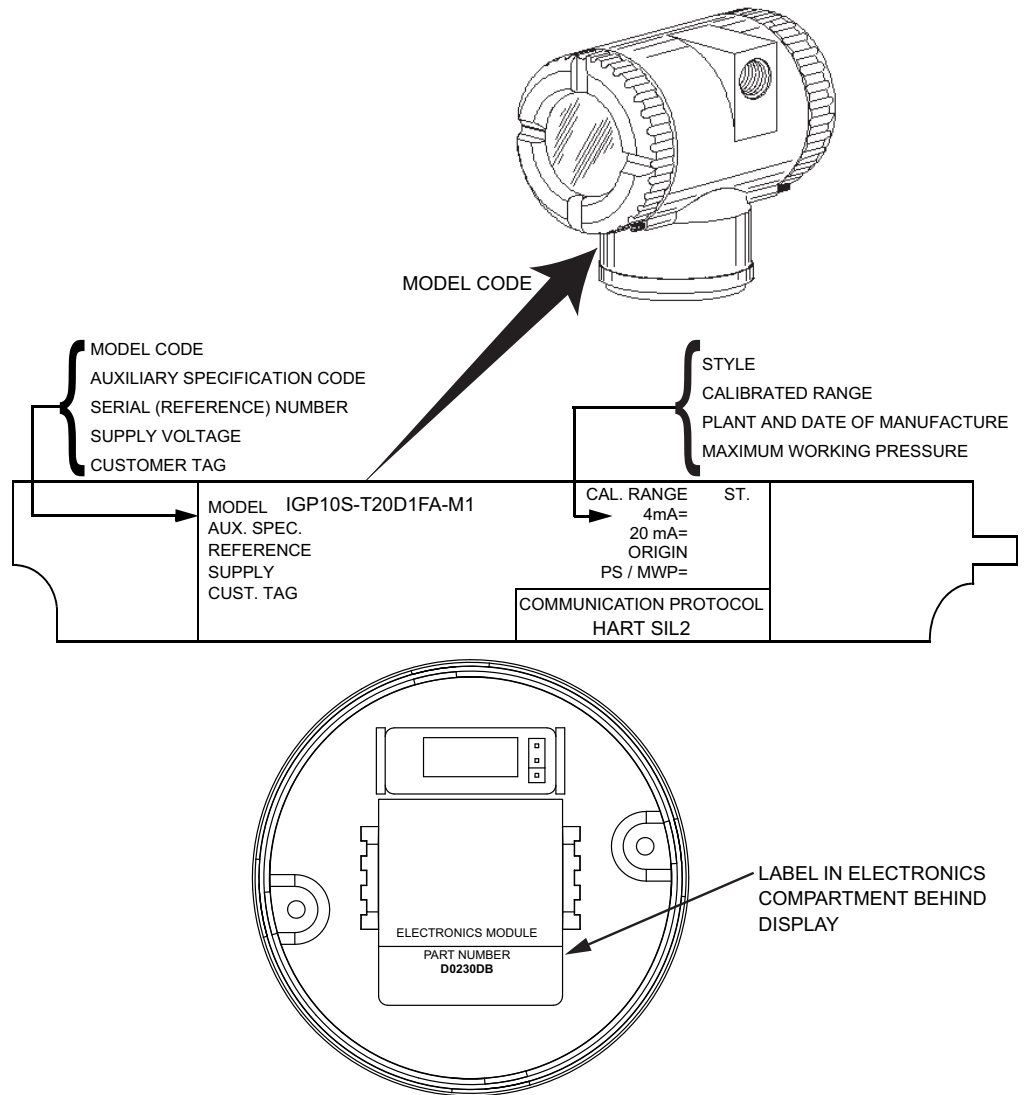

Standard Specifications

Operative Limits

Influence	Operative Limits ¹
Sensor Body Temperature²	
PVDF inserts	-7 and +82°C (+20 and 180°F)
Silicone fill fluid	-46 and +121°C (-50 and +250°F) ^{3 4}
Fluorinert fill fluid	-29 and +121°C (-20 and +250°F) ⁵
NEOBEE® fill fluid	-18 and +121°C (0 and 250°F)

1. Normal Operating Conditions and Operative Limits are defined per ANSI/ISA 51.1-1979 (R1993)
2. Refer to MI 020-369 for temperature limits with pressure seals.
3. Selection of Option -J extends the low temperature operative limit of transmitters with silicone filled sensors down to -50°C (-58°F). Performance is not assured below -29°C. Sensor damage may occur if process is frozen. Contact Global Customer Support for availability of this option.
4. -46 and +50°C (-50 and +122°F) for biplanar AP transmitters.
5. -18°C (0°F) for J range (IGP05S transmitters only).

Influence	Operative Limits ⁶
Electronics Temperature	
Without LCD	-40 and +85°C (-40 and +185°F) ^{7 8}
With LCD	-40 and +85°C (-40 and +185°F) ^{7 8 9}
Relative Humidity	0 and 100% ¹⁰
Supply Voltage	12.5 V dc and 42 V dc
Output Load	0 and 1,450 Ω ¹¹
Mounting Position	No limit
Vibration	
Aluminum Housing	Per IEC 60770 for "field with high vibration level or pipeline with high vibration level": 0.42 mm peak-to-peak displacement from 10 to 60 Hz, 3 "g" constant acceleration input over a frequency range of 60 to 1000 Hz
Stainless Steel Housing	Per IEC 60770 for "field with general application or pipeline with low vibration level": 0.3 mm peak-to-peak displacement from 10 to 60 Hz, 2 "g" constant acceleration input over a frequency range of 60 to 1000 Hz

Span and Range Limits

Limits for Direct Connect Transmitters

Table 1 - Span Limits for Direct Connect Transmitters

Code	Span Limits ¹²
D	3.4 and 1380 kPa (0.5 and 200 psi)
E	0.034 and 13.8 MPa (5 and 2000 psi)
F	0.52 and 41.4 MPa (75 and 6000 psi) ¹³
J	6.9 and 69 MPa (1000 and 10000 psig) ¹³
G	34.5 and 104 MPa (5000 and 15000 psig) ¹³
H	69 and 207 MPa (10000 and 30000 psig) ¹³

6. Normal Operating Conditions and Operative Limits are defined per ANSI/ISA 51.1-1979 (R1993)

7. -40 and +75°C (-40 and +167°F) for transmitters with ATEX flameproof classification.

8. -40 and +50°C (-40 and +122°F) for biplanar AP transmitters.

9. Display updates are slowed and readability is decreased at temperatures less than -20°C (-4°F).

10. Relative humidity refers to transmitters with housing covers installed and conduit entrances sealed. To maintain IEC IP66/IP67 and NEMA Type 4X protection, plug the unused conduit opening with the metal plug provided. Use a suitable thread sealant on both conduit connections. In addition, the threaded housing covers must be installed. Turn covers to seat the o-ring into the housing, then continue to hand-tighten until the cover contacts the housing metal-to-metal.

11. 250 Ω minimum load is required for communication with a HART communicator.

12. Values listed are in absolute or gauge pressure units, as applicable.

13. Available for gauge pressure transmitters only.

Table 2 - Range Limits for Direct Connect Transmitters

Code	Range Limits — AP	Range Limits — GP
D	0 and 1400 kPaa (0 and 200 psia)	0 and 1400 kPag (0 and 200 psig)
E	0 and 14 MPaa (0 and 2000 psia)	0 and 14 MPag (0 and 2000 psig) ¹⁴
F	n/a	0 and 42 MPag (0 and 6000 psig) ¹⁴
J	n/a	0 to 69 MPag (0 to 10000 psig) ¹⁵
G	n/a	0 and 104 MPag (0 and 15000 psig) ¹⁵
H	n/a	0 and 207 MPag (0 and 30000 psig) ¹⁵

Limits for Biplanar Transmitters

Table 3 - Span Limits for Biplanar Transmitters

Code	Span Limits ¹⁶
B	0.12 and 50 kPa (0.5 and 200 inH ₂ O)
C	0.62 and 250 kPa (2.49 and 1000 inH ₂ O)
D	26 and 2070 kPa (3.75 and 300 psi) ¹⁷
E	0.26 and 20.7 MPa (37.5 and 3000 psi) ¹⁷
F	1.1 and 34.5 MPa (165 and 5000 psi) ^{18 17}

Table 4 - Range Limits for Biplanar Transmitters

Code	Range Limits — AP	Range Limits — GP
B	0 and 50 kPaa (0 and 200 inH ₂ Oa) ¹⁹	-50 and +50 kPag (-200 and +200 inH ₂ Og)
C	0 and 250 kPaa (0 and 1000 inH ₂ Oa)	-100 and +250 kPag (-401 and +1000 inH ₂ Og)
D	0 and 2070 kPaa (0 and 300 psia) ¹⁷	-100 and +2100 kPag (-14.7 and +300 psig) ¹⁷
E	0 and 20.7 MPaa (0 and 3000 psia) ¹⁷	-0.1 and +21 MPag (-14.7 and +3000 psig) ¹⁷
F	n/a	-0.1 and +35 MPag (-14.7 and +5000 psig) ¹⁷

Limits for DP Transmitters

Table 5 - Span Limits for DP Transmitters

Code	Span Limits
B	0.12 and 50 kPa; 0.5 and 200 inH ₂ O; 1.2 and 500 mbar
C	0.62 and 250 kPa; 2.5 and 1000 inH ₂ O; 6.2 and 2500 mbar
D	0.026 and 2.07 MPa; 3.75 and 300 psi; 0.26 and 20.7 bar
E	0.26 and 20.7 MPa; 37.5 and 3000 psi; 2.6 and 207 bar

14. Direct connect GP transmitters with Span Code E or F can tolerate vacuum down to -0.1 MPa (-14.7 psi). However, to measure vacuum accurately with a GP transmitter, a biplanar Structure Code is required.
15. Direct connect GP transmitters with Span Code G, H, or J can tolerate vacuum down to -0.1 MPa (-14.7 psi). However, they cannot measure vacuum accurately.
16. Values listed are in absolute or gauge pressure units, as applicable.
17. Span limit, maximum working pressure, maximum overrange pressure, and maximum static pressure (d/p) are derated for optional IEC 61518 Construction and optional Bolting except for codes -D3, -D7, and -B2. Option -D1 is derated to 2320 psi. Options -D5 and -B1 are derated to 2175 psi. Options -D2, -D4, -D6, and -D8 are derated to 1500 psi. Option -B3 is derated to 2900 psi.
18. Available for gauge pressure transmitters only.
19. For Value (05S) transmitters only. Range limits for Advanced (10S) and Premium (50S) transmitters are 5 and 50 kPaa (20 and 200 inH₂Oa).

Table 6 - Range Limits for DP Transmitters

Code	Range Limits
B	-50 and +50 kPa (-200 and +200 inH ₂ O)
C	-250 and +250 kPa (-1000 and +1000 inH ₂ O)
D	-0.10 and +2.07 MPa (-14.7 and +300 psi)
E	0 and 21 MPa (0 and 3000 psi)

Maximum Static, Overrange, and Proof Pressure Ratings

⚠ DANGER

HAZARD OF EXPLOSION

Exceeding the proof pressure can cause the sensor to rupture forcefully. Avoid exposing the transmitter to the proof pressure limit.

Failure to follow these instructions will result in death or serious injury.

NOTICE

POTENTIAL EQUIPMENT DAMAGE

Exceeding the overrange pressure limit for the transmitter can cause damage to the transmitter, degrading its performance. The transmitter could become nonfunctional after exceeding the overrange pressure. Avoid exposure to the overrange pressure limit.

Failure to follow these instructions can result in equipment damage.

Ratings for Direct Connect AP and GP Transmitters

Table 7 - Maximum Overrange and Proof Pressure for Direct Connect Transmitters

Span Limit Code	Maximum Overrange Pressure	Maximum Proof Pressure ²⁰
D	2.1 MPa (300 psi)	5.51 MPa (800 psi)
E	20.7 MPa (3,000 psi)	55.1 MPa (8,000 psi)
F ²¹	59.1 MPag (8,580 psig)	165 MPa (24,000 psig)
J ²¹	99 MPag (14,300 psig)	180 MPa (26,015 psig)
G ²¹	137 MPag (19,500 psig)	310 MPa (45,000 psig)
H ²¹	231 MPag (33,000 psig)	567 MPa (81,000 psig)

Ratings for DP Transmitters and Biplanar AP and GP Transmitters

For DP transmitters and for AP and GP transmitters with biplanar structures, pressure ratings may be affected by bolting options and other model code selections.

20. Meets ANSI/ISA Standard S82.03-1988.

21. Available for gauge pressure transmitters only.

Table 8 - Maximum Static/Ovrange and Proof Pressure for DP and Biplanar Transmitters

Transmitter Configuration ²²	Maximum Static ²³ and Ovrange Pressure ²⁴	Maximum Proof Pressure ²⁵
Standard (B7 steel) with Span Codes A to E, or with Option -B2 (17-4 PH ss), -D3, -D7, -P3, or -P7	25 MPa (3,626 psi)	100 MPa (14,500 psi)
Standard with Span Code F ²⁶	40 MPa (5,800 psi)	100 MPa (14,500 psi)
Option -B3 (B7M), -P4, or -P8	20 MPa (2,900 psi)	70 MPa (11,150 psi)
With Option -D1	16 MPa (2,320 psi)	64 MPa (9,280 psi)
Option -B1 (316 ss), -D5, -P2, or -P6	15 MPa (2,175 psi)	60 MPa (8,700 psi)
With Option -D2, -D4, -D6, or -D8 ²⁷	10 MPa (1,500 psi)	40 MPa (6,000 psi)
Option -D9 (17-4 PH ss) or -Y ²⁸	40 MPa (5,800 psi)	100 MPa (14,500 psi)
With Structure Code 78 or 79 (PVDF insert) ²⁹	2.1 MPa (300 psi)	8.4 MPa (1,200 psi)

Elevated Zero and Suppressed Zero

For applications requiring an elevated or suppressed zero, do not exceed the maximum span and the upper and lower range limits of the transmitter.

Sensor Fill Fluid

- Silicone fluid — dodecamethylpentasiloxane
- 3M™ Fluorinert™ Electronic Liquid FC-43 — perfluorotributylamine
- NEOBEE® M-20 — propylene glycol di(octanoate/decanoate)

Minimum Allowable Absolute Pressure vs Process Temperature

- With silicone fill fluid: up to 121°C (250°F) at full vacuum³⁰
- With inert fill fluid: refer to the graph^{30 31}

22. Refer to the model code for option descriptions, and for applications and restrictions related to the items listed in the table.

23. Static pressure is relevant only for differential pressure transmitters.

24. Either side can be at higher pressure during overrange.

25. Meets ANSI/ISA Standard S82.03-1988.

26. Available for gauge pressure transmitters only.

27. Limited to operating temperatures ranging from -10 to +80°C (14 to 176°F).

28. Differential pressure transmitters only.

29. With PVDF insert, temperature limits are -7 and +82°C (20 and 180°F).

30. For direct connect IGP50S transmitters with Span Code D, the minimum allowable pressure is 0 psig.

31. For biplanar IAP50S transmitters, up to 50°C (120°F) at full vacuum.

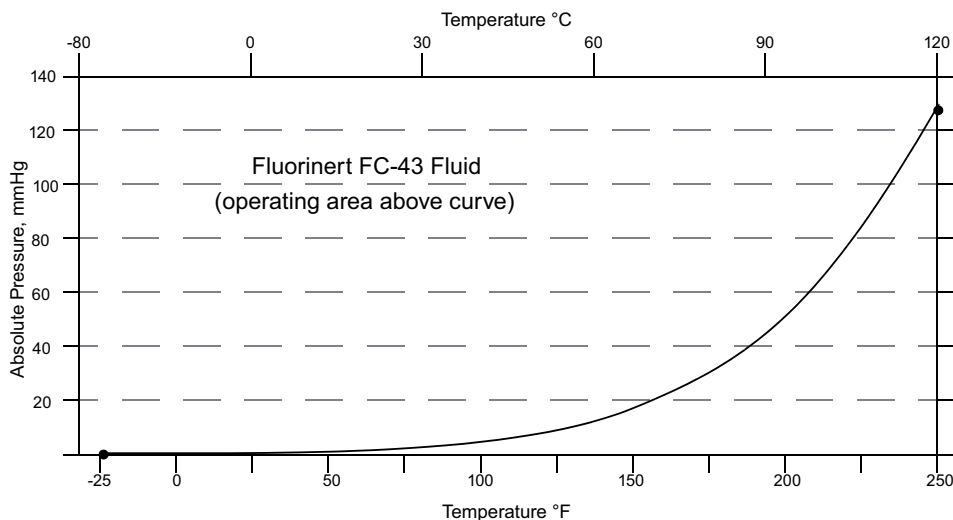

Mounting Position

The transmitter can be mounted in any orientation with considerations specified in *Installation, page 22*. The housing can be rotated up to one full turn to any desired position for access to adjustments, display, or conduit connections. Refer to *Positioning the Housing, page 42*.

The display (if applicable) can also be rotated at 90° increments within the housing. Refer to *Positioning the Display, page 42*.

NOTE:

- Mount the transmitter so that any moisture condensing or draining into the field wiring compartment can exit through one of the two threaded conduit connections.
- Use a suitable thread sealant on all connections.
- Position effect zero shift for all calibrated spans can be calibrated out by readjusting zero output after installation.

Approximate Mass

Transmitter mass does not include pressure seals.

Transmitter and Option(s)	Approximate Mass
Direct Connect AP or GP, Aluminum Housing	1.4 kg (3.1 lb)
Biplanar or Traditional DP Structure, Aluminum, <u>without</u> Process Connectors	3.5 kg (7.8 lb)
Biplanar or Traditional DP Structure, Aluminum, <u>with</u> Process Connectors	4.2 kg (9.2 lb)
Optional Display	Add 0.2 kg (0.4 lb)
Substitute 316 ss Housing	Add 1.1 kg (2.4 lb)
Low Profile/Biplanar LP1 Structure	Add 0.1 kg (0.2 lb)
Low Profile/Biplanar LP2 Structure	Add 0.8 kg (1.8 lb)

Process Connections

- AP and GP transmitters with direct connect structures can be connected directly to the process using their 1/2 NPT external/internal thread, M20 external thread, or optional G 1/2 B connection.

- If an optional mounting bracket is used, the transmitter can be connected to the process via the 1/2 NPT external/internal thread, M20 external thread, 1/4 NPT internal thread, or G 1/2 B (model code option -G) connection.
- Transmitters with a sanitary process connection connect to the process with a Tri-Clamp process connector or a mini tank spud seal.
- Transmitters with a pulp and paper process connection connect to the process with a threaded or sleeve type connection.
- DP transmitters, and AP or GP transmitters with biplanar structures, connect to the process via a 1/4 NPT thread or an optional process connector.

Process Wetted Materials

Process wetted parts compatible with NACE MR0175 and MR0103 are available.

Part	Material(s)
Diaphragm	316L ss, nickel alloy ³² , Co-Ni-Cr, Monel, gold-plated 316L ss, or tantalum
Process Connections ³³ and Covers	316 ss, nickel alloy ³² , Monel, or PVDF inserts
Pressure Seals	Refer to MI 020-369

Reference (Low) Pressure Side Materials

Silicone, Pyrex™, RTV silicone, or 316L ss.

Electrical Connections

Field wires enter through 1/2 NPT or M20 threaded entrances on either side of the electronics housing. Leads terminate under screw terminals and washers on the terminal block in the field terminal compartment.

 WARNING
<p>EXPLOSION HAZARD</p> <p>To help prevent possible explosions and to maintain flameproof, explosionproof, and dust-ignitionproof protection, observe applicable wiring practices. Plug the unused conduit openings with approved conduit plugs. Both plug and conduit must engage a minimum of five full threads for 1/2 NPT connections; seven full threads for M20 connections.</p> <p>Failure to follow these instructions can result in death or serious injury.</p>

Switching and Indirect Lightning Transients

The transmitter can withstand a transient surge up to 2000 V (common mode) or 1000 V (normal mode) without permanent damage. The output shift is less than 1.0%. (Per ANSI/IEEE C62.41-1980 and IEC Std. 61000-4-5.)

Field Wiring Reversal

Reversal of field wiring does not damage the transmitter, provided the current is limited to 1 A or less by active current limiting or loop resistance. However, the transmitter is polarity-sensitive.

32. Equivalent to Hastelloy® C-276. Hastelloy is a registered trademark of Haynes International, Inc.

33. Includes sanitary and pulp and paper process connections.

NOTE: Sustained currents of 1 A do not damage the electronics module or sensor, but can damage the terminal block assembly and external instruments in the loop.

Adjustable Damping

Damping is user-selectable to values of 0, 0.25, 0.5, 1, 2, 4, 8, 16, or 32 seconds. Selecting a value of **DAMP 0** in the Damping menu provides the fastest response.

Output Signal

4 to 20 mA dc square root (for DP only) or 4 to 20 mA dc linear with digital HART communication. The output is software-selectable and remotely configurable from the HART Communicator, and locally configurable with the pushbuttons on the optional display. HART 7 allows the mA signal to be fixed or live when multidrop is enabled.

External Zero Adjustment

An optional external self-contained moisture-sealed pushbutton allows you to locally reset to zero without removing the housing cover.

Supply Voltage

The power supply must be capable of providing 22 mA when the transmitter is configured for 4 to 20 mA output. Ripple of up to 2 V pp (50/60/100/120 Hz) is tolerable, but instantaneous voltage must remain within the specified range.

The supply voltage and loop load must be within specified limits. This is detailed in *Wiring the Transmitter to a Control Loop, page 45*.

The following table summarizes the requirements.

	HART Communication	No HART Communication
Minimum Resistance	250 Ω	0 Ω
Minimum Supply Voltage	15.5 V dc	12.5 V dc

Electrical Ground Connections

The transmitter is equipped with an internal ground connection within the field wiring compartment and an external ground connection at the base of the electronics housing. To minimize galvanic corrosion, place the wire lead or contact between the captive washer and loose washer on the external ground screw.

If shielded cable is used, ground the shield at the field enclosure only.

HART Communicator Connection Points

The HART communicator can be connected in the loop as shown in *Accessing Transmitter Field Terminals, page 44*. It can also be connected directly to the transmitter at the two upper banana plug receptacles.

Test Points

The two lower banana plug receptacles (designated **CAL**) can be used to check transmitter output when configured for 4 to 20 mA. Measurements should be 100 to 500 mV dc for 0 to 100% transmitter output. See *Accessing Transmitter Field Terminals, page 44*.

Remote Communication

The transmitter communicates bidirectionally over the 2-wire field wiring to a HART Communicator.

Communication Format

Communication is based upon the FSK (Frequency Shift Keying) technique. The frequencies are superimposed on the transmitter power/signal leads.

4 to 20 mA Output

The transmitter sends its pressure measurement to the loop as a continuous 4 to 20 mA dc signal. It also communicates digitally with the HART Communicator at distances up to 3,000 m (10,000 ft). Communication between the remote configurator and the transmitter does not disturb the 4 to 20 mA output signal. Other specifications are:

Data transmission rate	1200 baud
4 to 20 mA update rate	30 times/second
Output for Low Alarm	≤ 3.60 mA
Output for High Alarm	≥ 21.00 mA
Output when underrange	3.8 mA
Output when overrange	20.5 mA
Output when offline	User-configurable to a constant value between 3.6 mA and 21.0 mA

Agency Certifications

WARNING

EXPLOSION HAZARD

To help prevent possible explosions and to maintain flameproof, explosionproof, and dust-ignitionproof protection, observe applicable wiring practices. Plug the unused conduit openings with approved conduit plugs. Both plug and conduit must engage a minimum of five full threads for 1/2 NPT connections; seven full threads for M20 connections.

Failure to follow these instructions can result in death or serious injury.

WARNING

RISK OF MOISTURE INGRESS

To maintain IEC IP66/IP67 and NEMA Type 4X protection, plug the unused conduit opening with the metal plug provided. Use a suitable thread sealant on both conduit connections. In addition, the threaded housing covers must be installed. Turn covers to seat the o-ring into the housing, then continue to hand-tighten until the cover contacts the housing metal-to-metal.

Failure to follow these instructions can result in death or serious injury.

Wiring restrictions required to maintain electrical certification of the transmitter are provided in these instructions. Refer to *Wiring*, page 44.

Electrical Certifications

These transmitters have been designed to meet the electrical safety descriptions listed in the following table. For detailed information or status of testing laboratory approvals/certifications, contact Global Customer Support.

Refer to *Model Codes, page 114* for the availability of electrical safety design codes with specific transmitter structures.

Table 9 - Electrical Certifications

Agency Certification, Types of Protection, and Area Classification	Application Conditions ³⁴	Model Code Option
ATEX intrinsically safe, Ex ia IIC	Temperature Class T4, Ta= -40°C to +80°C	AA
ATEX flameproof, Ex d IIC	Temperature Class T6, T85°C, Ta= -40°C to +75°C	AD
ATEX multiple certifications (includes ATEX Codes AA and AN)	Applies to Codes AA and AN	AM ³⁵
ATEX protection type n, Ex ic IIC, or Ex nA	Temperature Class T4, Ta= -40°C to +80°C	AN
ATEX multiple certifications (includes ATEX Codes AA, AD and AN)	Applies to Codes AA, AN, and AD	AP ³⁵
INMETRO intrinsically safe, Ex ia IIC	Temperature Class T4, Ta= -40°C to +80°C	BA
INMETRO flameproof, Ex d IIC	Temperature Class T6, T85°C, Ta= -40°C to +75°C	BD
INMETRO multiple certifications (includes INMETRO Codes BA and BD)	Applies to codes BA and BD	BP ³⁵
CSA intrinsically safe, Zone certified Ex ia	Temperature Class T4A at 40°C and T3C at 85°C maximum ambient	CA
CSA zone certified flameproof Ex d IIC; also explosion proof, dust ignition-proof	T6, Maximum Ambient Temperature 75°C	CD
CSA multiple certifications (includes CSA Codes CA and CN)	Applies to codes CA and CN	CM ³⁵
CSA non-incendive, Zone certified Ex nA IIC	Temperature Class T4A at 40°C and T3C at 85°C maximum ambient	CN
CSA multiple certifications (includes CSA Codes CA, CD and CN)	Applies to codes CA, CD, and CN	CP ³⁵
Multi-marked ATEX and IECEx intrinsically safe, Ex ia IIC	Temperature Class T4, Ta = -40°C to +80°C	DA
Multi-marked ATEX and IECEx flameproof, Ex d IIC	Temperature Class T6, T85°C, Ta = -40°C to +75°C	DD
Multi-marked ATEX and IECEx multiple certifications, ia, ic	Applies to codes DA and DN	DM ³⁵
Multi-marked ATEX and IECEx protection type n, Ex ic IIC	Temperature Class T4, Ta = -40°C to +80°C	DN
Multi-marked ATEX and IECEx multiple certifications, ia, ic, and d	Applies to codes DA, DD, and DN	DP ³⁵
IECEX intrinsically safe, Ex ia IIC	Temperature Class T4, Ta= -40°C to +80°C	EA
IECEX flameproof, Ex d IIC	Temperature Class T6, T85°C, Ta = -40°C to +75°C	ED
IECEX multiple certifications, ia, ic, nA	Applies to Codes EA and EN	EM ³⁵
IECEX protection type n, Ex ic IIC, or Ex nA	Temperature Class T4, Ta= -40°C to +80°C	EN
IECEX multiple certifications, ia, ic, nA, and d	Applies to Codes EA, EN, and ED	EP ³⁵
FM Classes I, II and III Division 1 intrinsically safe, AEx ia IIC	Temperature Class T4, Ta= -40°C to +80°C	FA
FM Classes I, II and III Division 1 explosion proof, dust-ignition proof, Zone approved AEx d IIC	Temperature Class T6 at 75°C and T5 at 85°C maximum ambient	FD
FM multiple certifications (includes FM Codes FA or FN)	Applies to codes FA or FN	FM ³⁵

34. Selection of Option -J extends the low temperature operative limit of transmitters with silicone filled sensors down to -50°C (-58°F).

35. When selecting an Electrical Safety Design Code that ends in "M" or "P," you must permanently mark (check off in the rectangular block on the data plate) one type of protection only (ia, d, n, IS, NL, or XP). Do not change this mark once it has been applied.

Table 9 - Electrical Certifications (Continued)

Agency Certification, Types of Protection, and Area Classification	Application Conditions ³⁶	Model Code Option
Classes I, II and III FM Division 2 non-incendive, Zone approved AEx nA IIC	Temperature Class T4, Ta= -40°C to +80°C	FN
FM multiple certifications (includes FM Codes FA, FD or FN)	Applies to codes FA, FD, or FN	FP ³⁷
KOSHA Ex d	Temperature Class T6, T85°C, Ta = -40°C to +75°C	KD
EAC intrinsically safe, Ex ia	Temperature Class T4, Ta= -40°C to +80°C	RA
EAC flameproof, Ex d	Temperature Class T4, Ta= -40°C to +75°C	RD
EAC protection type n, Ex ic IIC or Ex nA	Temperature Class T4, Ta= -40°C to +80°C	RN
No certification	n/a	ZZ

36. Selection of Option -J extends the low temperature operative limit of transmitters with silicone filled sensors down to -50°C (-58°F).

37. When selecting an Electrical Safety Design Code that ends in "M" or "P," you must permanently mark (check off in the rectangular block on the data plate) one type of protection only (ia, d, n, IS, NL, or XP). Do not change this mark once it has been applied.

Installation

⚠ DANGER

HAZARD OF ELECTRIC SHOCK, EXPLOSION, OR ARC FLASH

The main electronics enclosure for some models is manufactured from an aluminum alloy. In rare cases, ignition sources due to impact and friction sparks could occur. This must be considered during installation, particularly if the equipment is installed in a Zone 0 location.

Failure to follow these instructions will result in death or serious injury.

⚠ ⚠ WARNING

RISK OF ELECTROSTATIC CHARGE AND DUST INGRESS

- When installed in a flammable dust zone, under certain extreme circumstances an incendive electrostatic charge may build up on the painted surfaces, which are non-conducting. Therefore, take precautions to prevent the build-up of electrostatic charge; for example, place the equipment in a location where a charge-generating mechanism (such as wind-blown dust) is unlikely to be present, and clean with a damp cloth.
- When installed in a flammable dust zone, ensure that the cable entry maintains the dust-tightness (IP6X) of the enclosure.

Failure to follow these instructions can result in death, serious injury, or equipment damage.

NOTICE

POTENTIAL EQUIPMENT DAMAGE

To avoid damage to the transmitter sensor, do not use any impact devices, such as an impact wrench or stamping device, on the transmitter.

Failure to follow these instructions can result in equipment damage.

Transmitter Mounting

All transmitters can be mounted to a vertical or horizontal pipe or surface using the optional mounting set. See *Pipe Mounting, page 23* and *Surface Mounting, page 24*.

In addition, direct connect (non-biplanar) absolute and gauge pressure transmitters can be connected directly to the process; see *Direct Connected AP and GP Transmitter Mounting, page 24*. Differential pressure transmitters can be supported by the process piping; see *Process Mounting of a DP Transmitter Supported by Process Piping, page 25*.

Refer to *Dimensions, page 101* for dimensional information.

When mounting the transmitter, take these considerations into account:

- Mount the transmitter so that any moisture condensing or draining into the field wiring compartment can exit through one of the two threaded conduit connections.
- Use a suitable thread sealant on all connections.
- Do not mount the transmitter directly to the process using the 1/4 NPT internal thread. Use this thread only to connect to the process when the transmitter is mounted with an optional mounting set (Options -M1 through -M8).

- Do not mount the transmitter using the conduit connection and optional mounting set (-M1 through -M6) when vibration conditions exceed 20 m/s² (2 "g").
- If the transmitter is not installed in the vertical position, readjust the zero output to help eliminate the position zero effect.

NOTE: An absolute pressure transmitter cannot be zeroed by venting the transmitter to atmosphere.

- If structure codes 78/79 (PVDF inserts) are used with the transmitter, make the process connection directly to the PVDF inserts in the high and low side process covers.
- Where necessary, intrinsically safe equipment may be connected and disconnected while the circuits are energized.
- When used in a dust zone with flammable dusts, fibers, and flyings in groups IIIA, IIB, or IIC, the layer auto-ignition temperature must be at least 75°C greater than the maximum surface temperature marked in the dust coding.
- The equipment is certified for use only in ambient temperatures marked on the equipment and should not be used outside this range.
- Do not exceed the maximum process pressure indicated on the marking.
- There are no special checking or maintenance conditions. Periodically inspect all explosion-protected equipment in accordance with the applicable code of practice.

Figure 2 - Pipe Mounting

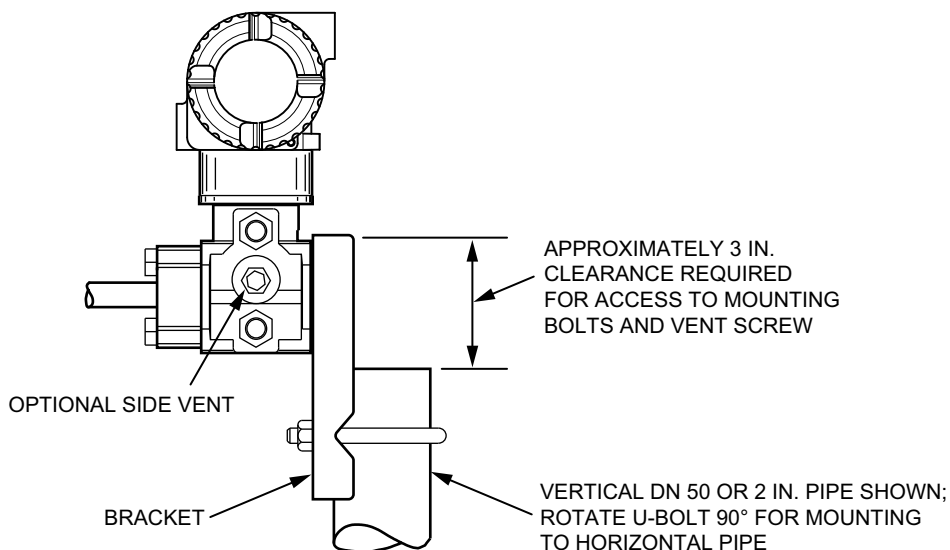

Figure 3 - Surface Mounting

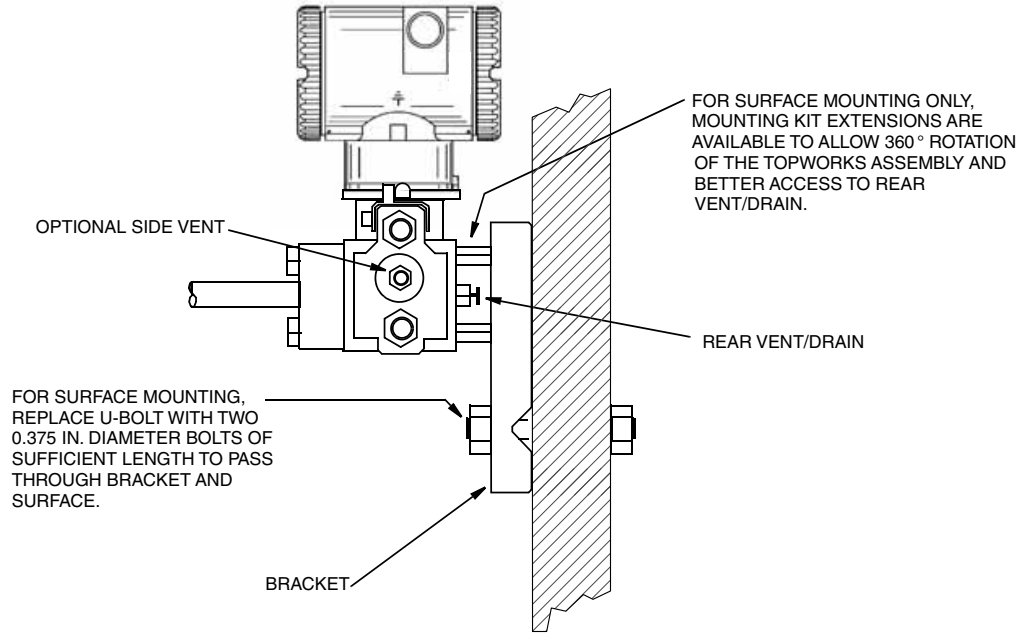

Figure 4 - Direct Connected AP and GP Transmitter Mounting

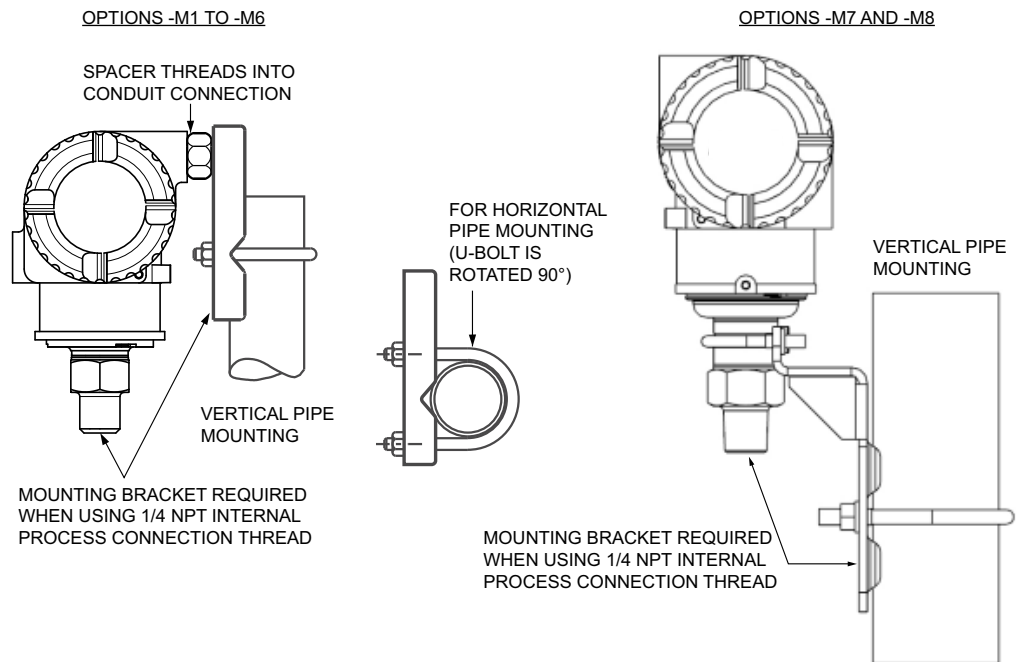
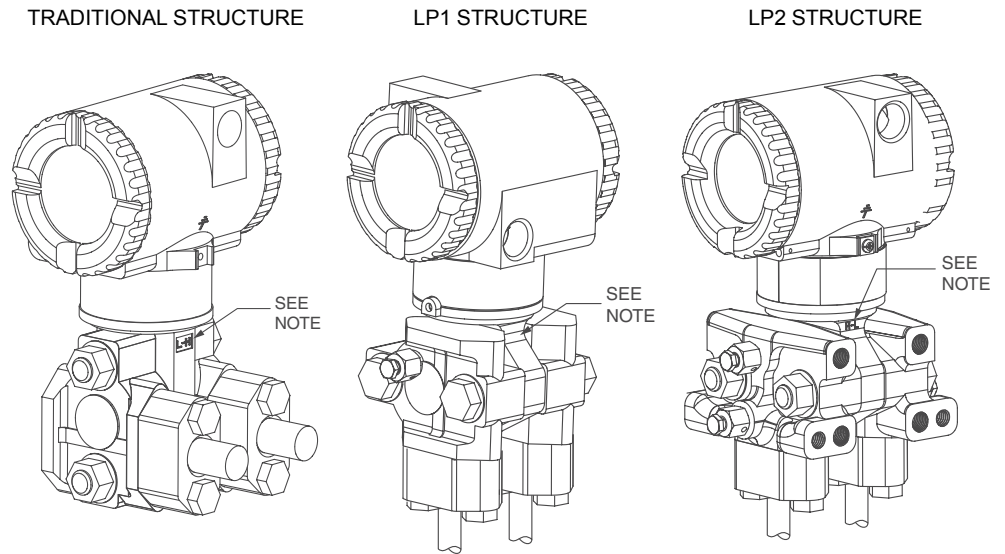

Figure 5 - Process Mounting of a DP Transmitter Supported by Process Piping



NOTE: MARK INDICATING LOW AND HIGH PRESSURE SIDES OF TRANSMITTER

Sanitary Process Connections

Transmitters with a sanitary process connector employ a Tri-Clamp type connection or a mini tank spud seal. Install the transmitter as shown.

For dimensional information, refer to the following documents:

- Tri-Clamp Type Connectors: DP 020-218
- Mini Tank Spud Connectors: DP 020-219

Figure 6 - Mounting a Transmitter with a Sanitary Tri-Clamp Type Connection

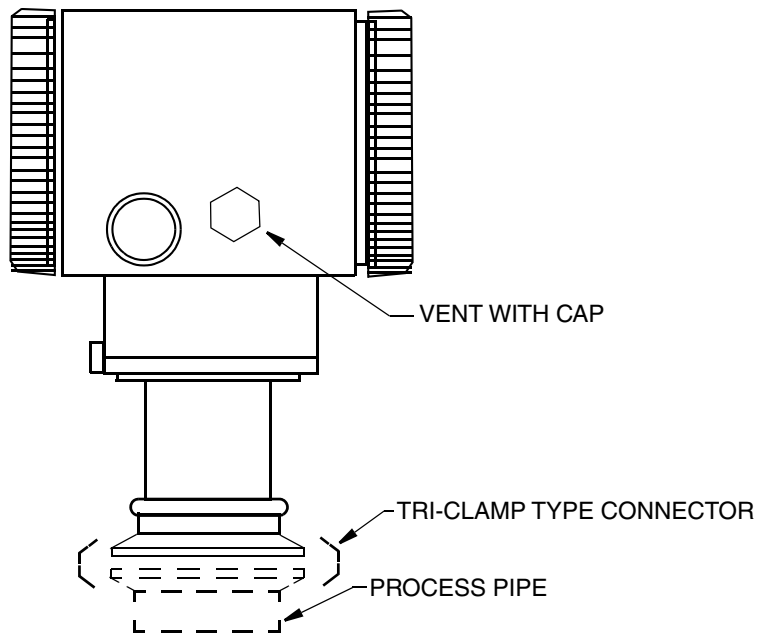
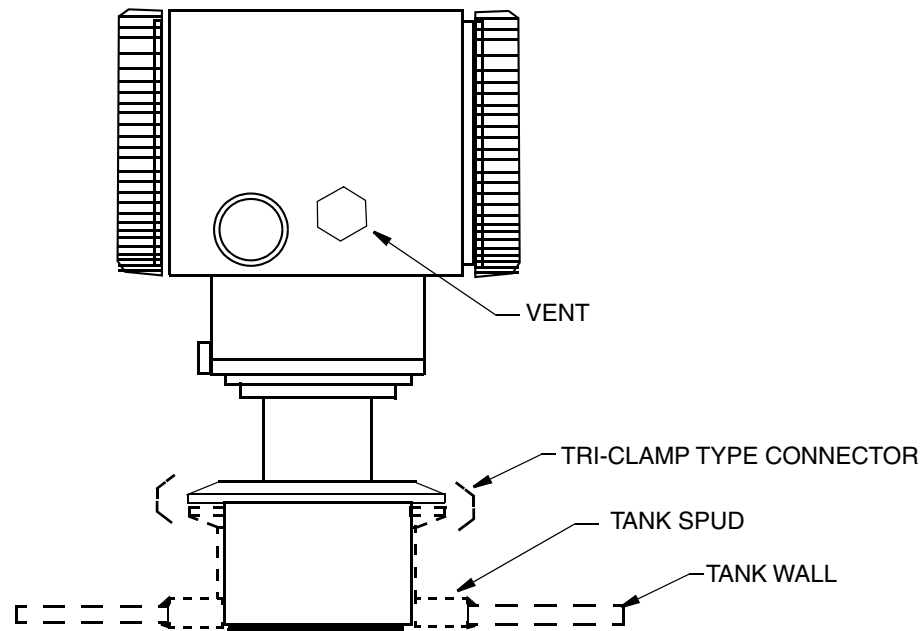

Figure 7 - Mounting a Transmitter with a Sanitary Mini Tank Spud Seal

- If the transmitter is to be mounted horizontally (side of a tank), orient the housing so that the vent is self-draining. **Do not mount the vent facing up.**
- If the vent faces downward, remove the protective cap.
- If the vent clogs, replace it with Part Number D0186DQ (W.L.Gore part number PMF200444). Stock vents and replace them at a predetermined interval as part of preventive maintenance. When installing a new vent, apply torque of 0.6 to 0.8 N-m (5 to 7 lbf-in).
- If the transmitter is subject to routine washdown such as in typical sanitary applications and the vent is oriented so that it is self-draining, the vent will stay clear, and longer intervals between preventive maintenance may be realized.
- If the vent becomes clogged, the resulting pressure measurement error may be as much as 1.5 inH₂O per degree C change in temperature. This value is positive with decreasing temperature, and negative with increasing temperature.

Welding the Tank Spud

Weld the tank spud into a hole cut in the tank as follows:

1. Cut a hole into the process vessel to accept the spud. The spud should fit snugly and uniformly. The nominal diameter of the spud is 3.73 inch (94.7 mm). To assure that the seal is always covered by process fluid, the top of the hole should be below the minimum measurement level.
2. Position the spud mounting ring so that it aligns as closely as possible with the inside wall of the tank, and the weep hole is at the bottom.
3. Tack weld the spud mounting ring to the outside of the tank in four places.
4. Weld the spud mounting ring to the inner surface of the tank:
 - a. Spud is 316 stainless steel. Use a compatible welding rod. Do not distort the spud mounting ring by using excessive heat.
 - b. Weld the spud mounting ring in sections as indicated in the diagram.
 - c. After each section is welded, cool right away with water until the temperature is less than 370°C (700°F) before welding the next section.
5. Grind the weld smooth so the surface is free from irregularities where dirt can lodge.

6. After completing the inner weld, the outer surface can also be welded if desired.

Figure 8 - Welding Procedure

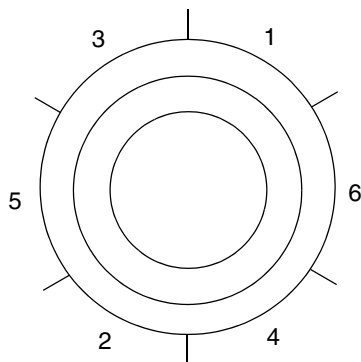

Pulp and Paper Process Connections

Transmitters with pulp and paper process connectors are available in two designs — sleeve type and threaded type. For dimensional information, refer to DP 020-217.

Sleeve-Type Connectors

1. Cut a hole into the process vessel to accept the weld spud. The spud should fit snugly and uniformly. The nominal diameter of the spud is:
 - Nominal 1 inch connector: 33.4 mm (1.32 inch)
 - Nominal 1 1/2 inch connector: 48.3 mm (1.90 inch)
2. Position the sleeve into the hole so that it aligns as closely as possible with the inside wall of the vessel.
3. Tack weld using the welding sequence shown in *Welding Procedure, page 27*. Cool each section with water until the temperature is below 370°C (700°F) before proceeding to the next section.
4. Weld the circumference of the sleeve using a compatible stainless steel welding rod.

NOTE: The welder should meet the requirements of ANSI B31.3, ASME Section IX, or other codes, if applicable.
5. Lubricate the o-ring with appropriate lubricant and install it into the sleeve, ensuring that it is properly seated.

NOTE: If the gasket is not properly seated, a process leak may occur.
6. Insert the transmitter sensor into the sleeve and hold it in place with cap screws.

Figure 9 - Mounting a Transmitter with a Sleeve-Type Pulp and Paper Process Connection

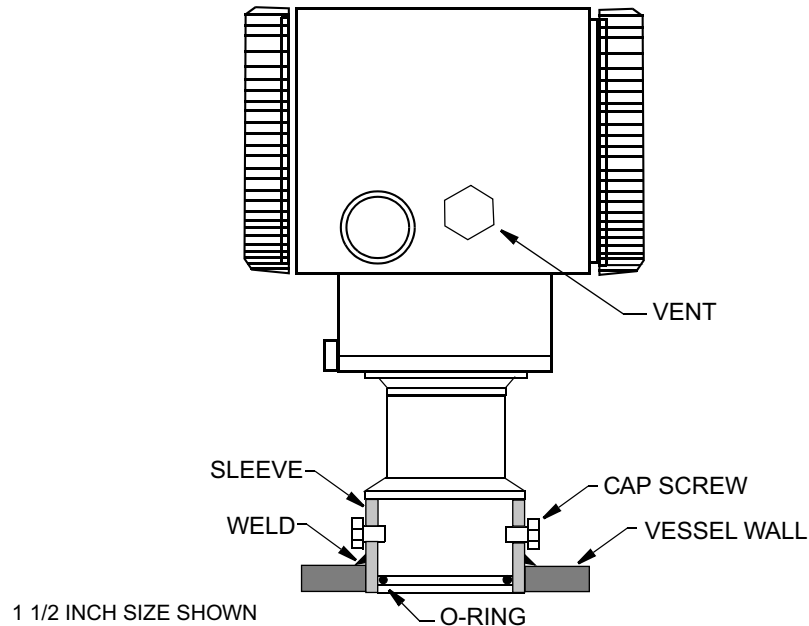

Threaded-Type Connectors

- Cut a hole into the process vessel to accept the weld spud. The spud should fit snugly and uniformly. The nominal diameter of the spud is:
 - Nominal 1 inch connector: 38.1 mm (1.50 inch)
 - Nominal 1 1/2 inch connector: 60.3 mm (2.38 inch)
 - Nominal 1 1/2 inch connector for Ametek spud: 50.5 mm (1.99 inch)
- Position the connector into the hole so that it aligns as closely as possible with the inside wall of the vessel.
- Tack weld using the welding sequence shown in *Welding Procedure, page 27*. Cool each section with water until the temperature is below 370°C (700°F) before proceeding to the next section.

NOTE: Use a heat sink during this operation.

- 1 inch size: Part Number N1214YS
- 1 1/2 inch size: Part Number N1214YR

- Weld the circumference of the connector using a compatible stainless steel welding rod.

NOTE: The welder should meet the requirements of ANSI B31.3, ASME Section IX, or other codes, if applicable.

- After the connector has cooled, remove the heat sink.
- Lubricate the gasket with an appropriate lubricant and install it into the connector, ensuring that it is properly seated.

NOTE: If the gasket is not properly seated, a process leak may occur.

- Thread the sensor into the connector hand-tight. Then tighten approximately 1/8 turn more.

Figure 10 - Mounting a Transmitter with a Threaded-Type Pulp and Paper Process Connection

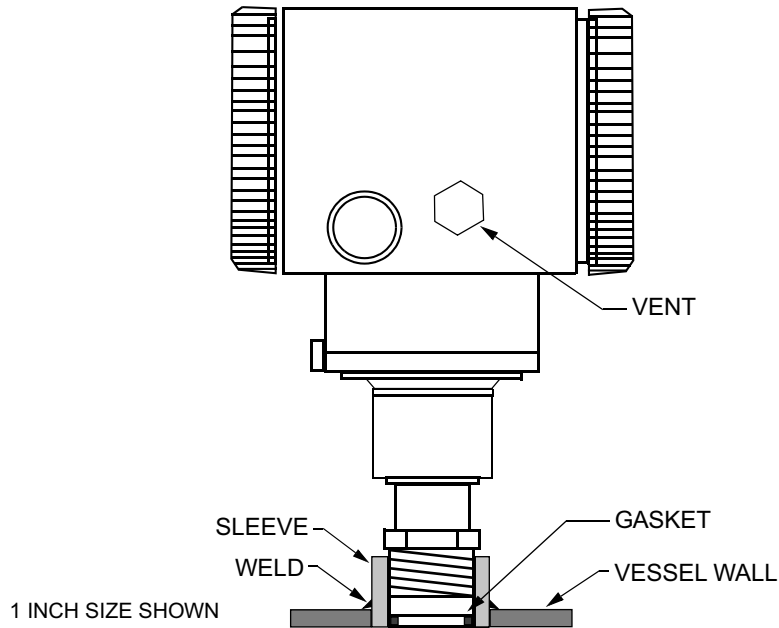

Manifold Mounting of Differential Pressure Transmitters

With manifold mounting, the transmitter is mounted to and supported by a bypass manifold. The bypass manifold can be mounted to a DN 50 or 2 inch pipe with an optional mounting bracket. See MI 022-138.

Figure 11 - Typical Mounting of a DP Transmitter Supported by a Bypass Manifold

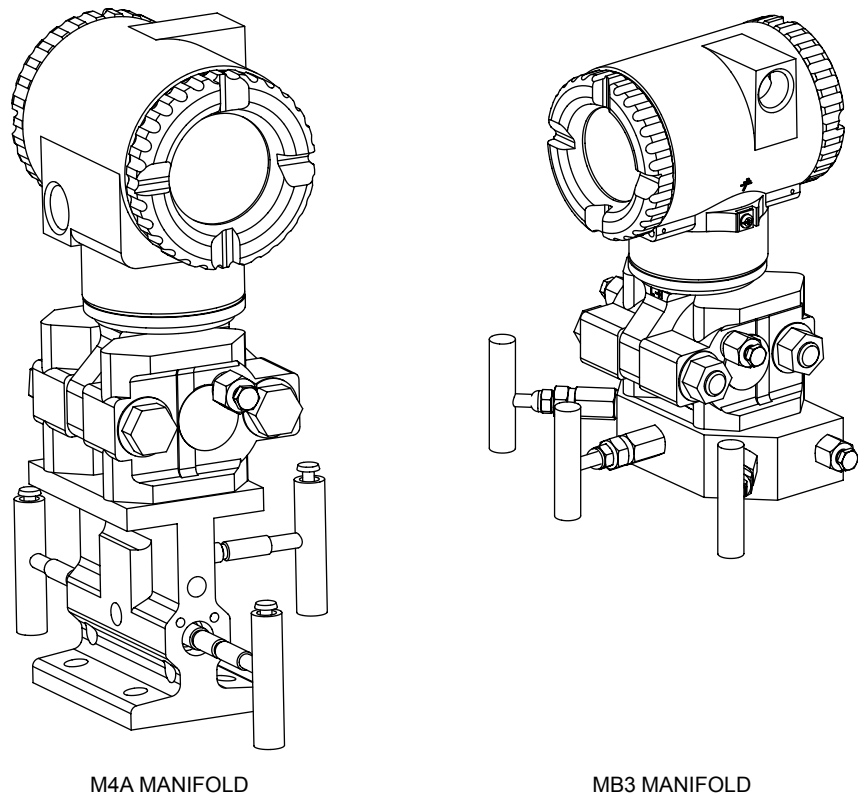
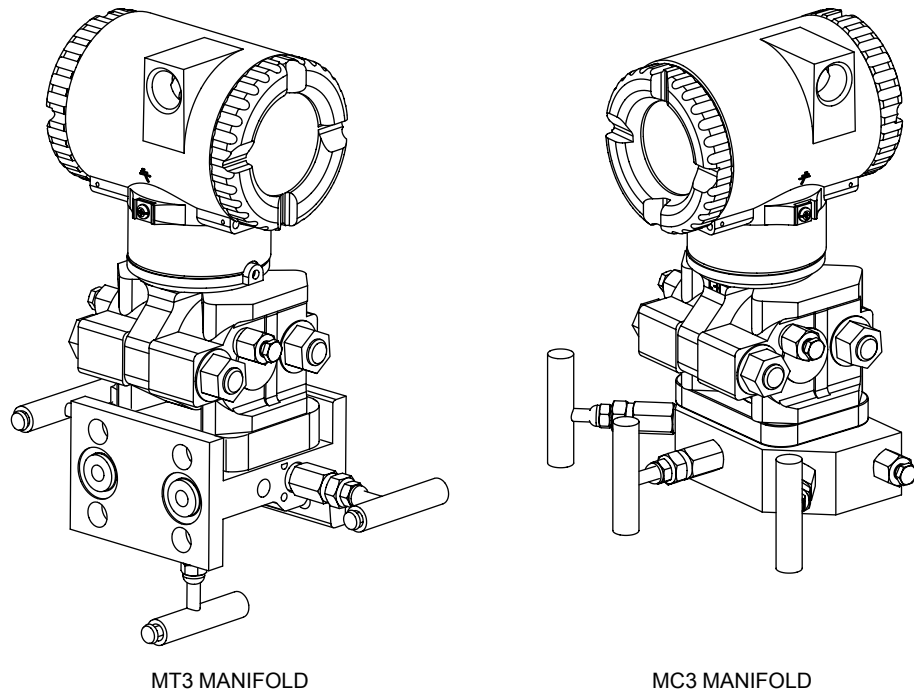

Figure 12 - Typical Mounting of a DP Transmitter on a Coplanar™ Manifold

MT3 MANIFOLD

MC3 MANIFOLD

Mounting a Differential Pressure Transmitter Using a Bracket

To mount a DP transmitter to a pipe or surface, use the Standard Mounting Bracket Set (Model Code Option -M1 or -M2), or the Universal Bracket Mounting Set (Model Code Option -M3).

Standard Mounting Bracket

A DP transmitter with either traditional or LP2 low profile structure can be mounted to a vertical or horizontal DN 50 or 2 in pipe using a standard bracket. See the following figures for details and examples.

Secure the mounting bracket to the transmitter using the four screws provided. Mount the bracket to the pipe. The mounting bracket can also be used for wall mounting by securing the bracket to a wall using the U-bolt mounting holes.

Figure 13 - Pipe or Surface Mounted DP Transmitter Using a Standard Bracket

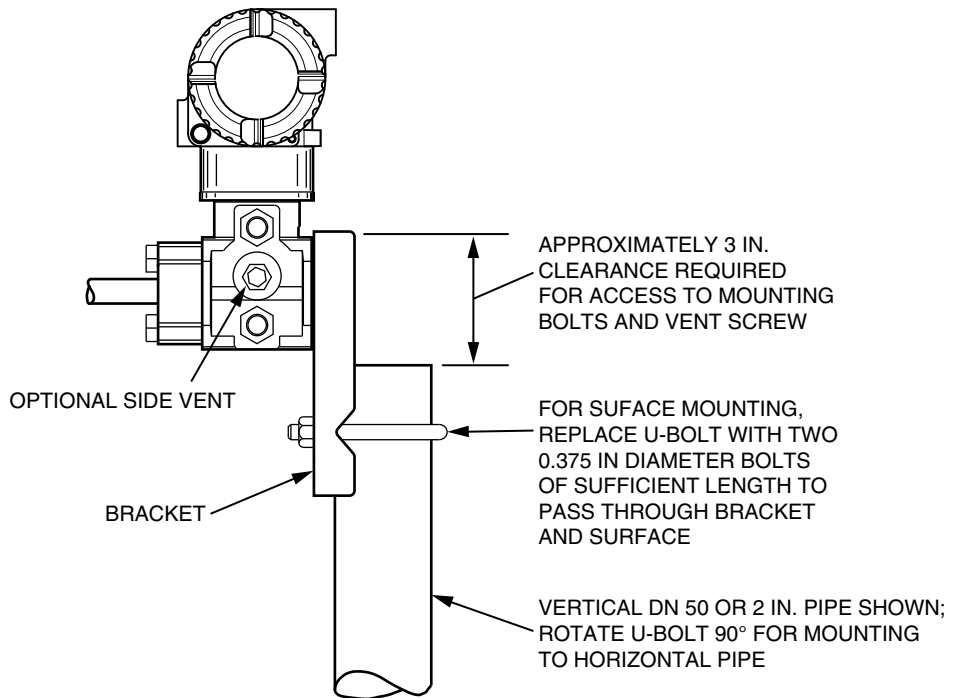
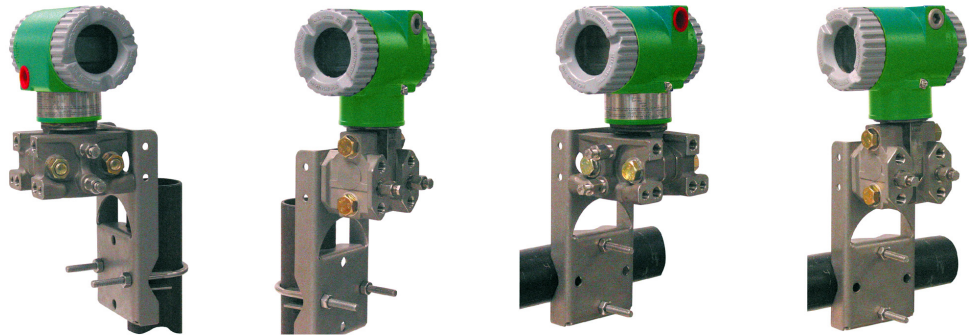

Figure 14 - Examples of DP Transmitters Mounted with a Standard Bracket



Universal Mounting Bracket

A DP transmitter with either traditional or LP2 low profile structure can be mounted in a myriad of positions to a vertical or horizontal DN 50 or 2 in pipe using a universal bracket. See the following figures for details and examples.

Secure the mounting bracket to the transmitter using the two long or four short screws provided. Mount the bracket to the pipe. The mounting bracket can also be used for wall mounting by securing the bracket to a wall using the U-bolt mounting holes.

Figure 15 - Universal Bracket Detail

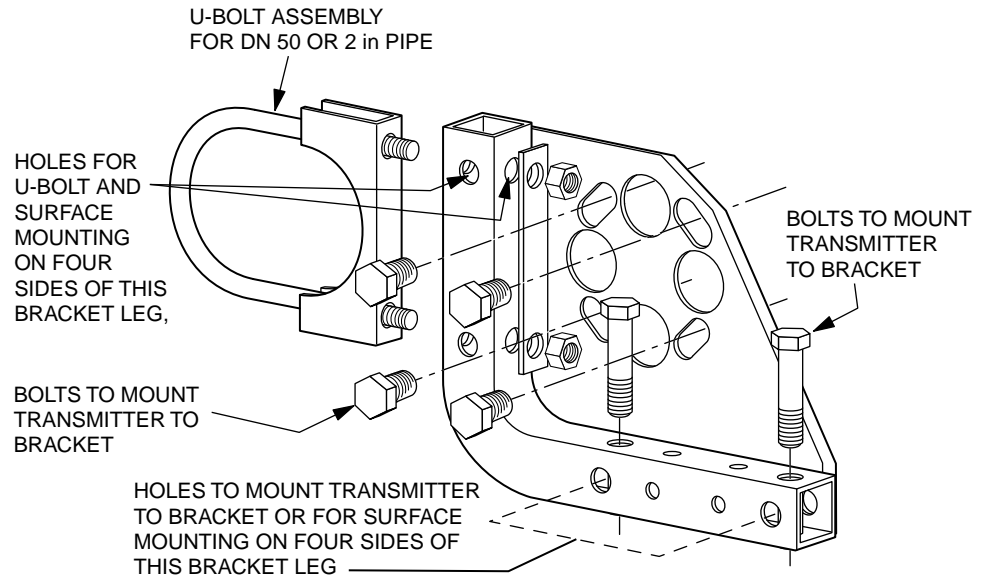

Figure 16 - Mounting a Traditional Structure DP Transmitter with a Universal Bracket

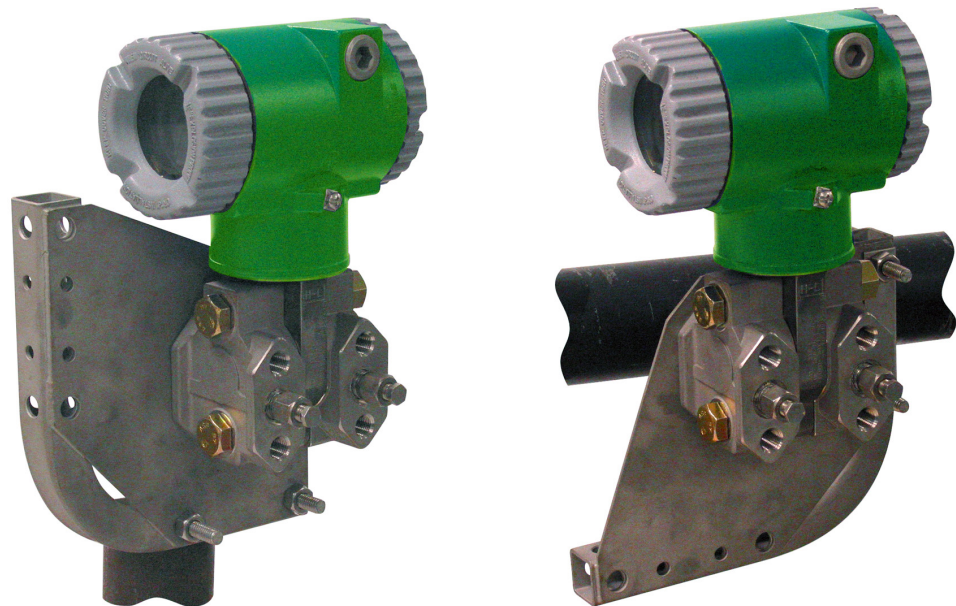

Figure 17 - Mounting a LP2 Structure DP Transmitter to a Vertical Pipe with a Universal Bracket

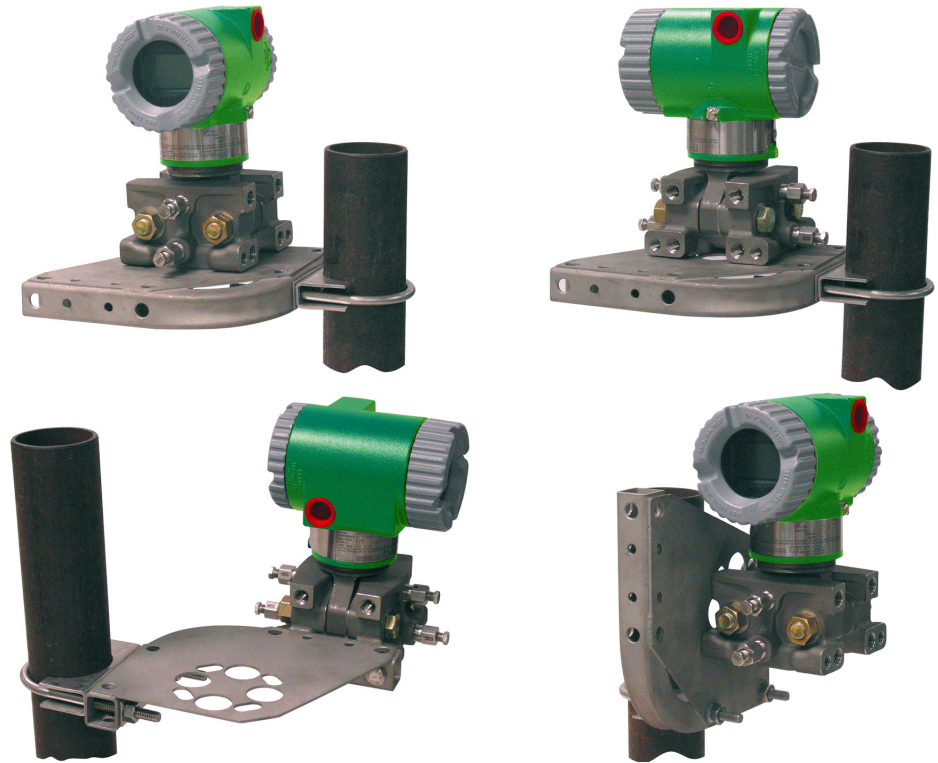

Figure 18 - Mounting a LP2 Structure DP Transmitter to a Horizontal Pipe with a Universal Bracket



Typical Piping for Absolute and Gauge Pressure Transmitters

Piping for Direct Connect AP and GP Transmitters

The next figure shows a typical piping application for direct connected transmitters. Calibration supply pressure can be applied via a calibration screw. The lower conduit port can be used as a drain for moisture buildup in terminal compartment.

NOTE:

- The use of snubbers is recommended in installations that are prone to high levels of fluid pulsations.
- Pressure transmitters mounted directly to process piping or a pressure vessel may require the use of a shutoff valve (shown) to comply with the requirements of ASME Power Piping Code B31.1 and Chemical and Petroleum Piping Code B31.3.

Figure 19 - Typical Direct Connect Transmitter Piping

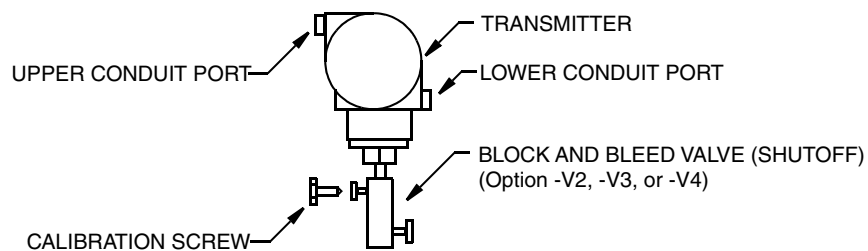

- Block and bleed valve maximum pressure:
 - 40 MPa (6,000 psi) at 38°C (100°F)
 - 25 MPa (4,000 psi) at 250°C (400°F)
- Calibration screw maximum pressure
 - 0.7 MPa (100 psi) with Poly-Flo fitting (F0101ES)

For hot process applications greater than the operative limits of your transmitter³⁸ — such as steam — additional piping is required to help protect the transmitter from the hot process as shown in the diagram. The piping is filled with water or process fluid. Mount the transmitter below the pressure connection at the pipe.

Although the transmitter is shown mounted vertically, you can also mount it horizontally unless sediment is present. The calibration tee is not required if a calibration screw is used for field calibrations.

If trapped vapor pockets cannot be tolerated in a liquid service and a horizontal process connection is used, install a pipe elbow and vertically position the transmitter with the housing *below* the process connection.

38. 121°C (250°F) for silicone fill fluid, or 82°C (180°F) for Fluorinert fill fluid

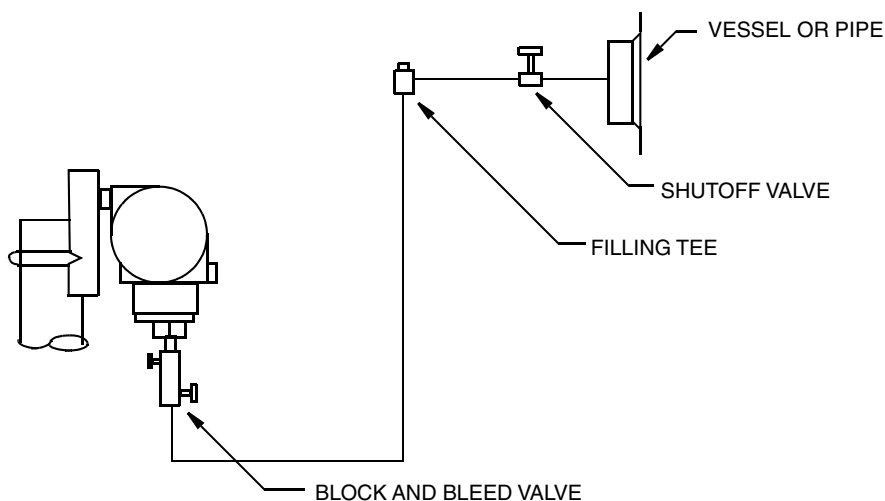
Figure 20 - Hot Process Piping for Direct Connect Transmitters

Piping for Biplanar AP and GP Transmitters

The next figure shows a typical piping application for biplanar transmitters.

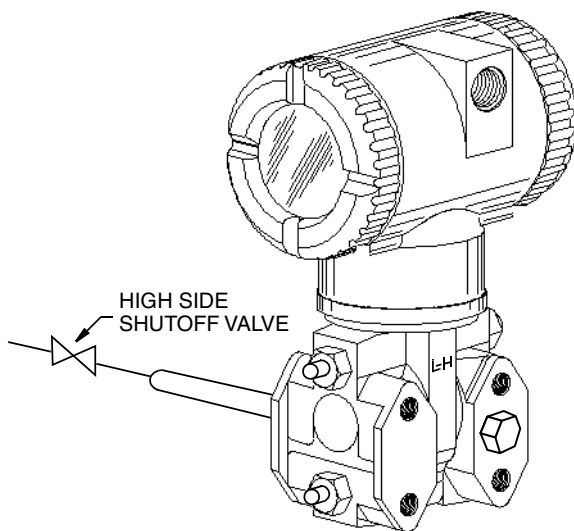
Figure 21 - Typical Biplanar Transmitter Piping

To achieve pressure-tight joints, tighten NPT thread one-half to three turns past hand-tight.

Tighten bolts, plugs, and screws to approximately the following torque values:

- Process connector bolts: 61 N-m (45 lbf-ft)
- Drain plugs: 47 N-m (35 lbf-ft)
- Vent and drain screws: 6.8 N-m (5 lbf-ft)

NOTE: The use of snubbers is recommended in installations that are prone to high levels of fluid pulsations.

For hot process applications greater than the operative limits of your transmitter³⁹ — such as steam — additional piping is required to help protect the transmitter from the hot process as shown in the diagram. The piping is filled with water or process fluid. Mount the transmitter below the pressure connection at the pipe.

39. 121°C (250°F) for silicone fill fluid, or 82°C (180°F) for Fluorinert fill fluid.

Although the transmitter is shown mounted vertically, you can also mount it horizontally unless sediment is present. The calibration tee is not required if a calibration screw is used for field calibrations.

If trapped vapor pockets cannot be tolerated in a liquid service and a horizontal process connection is used, install a pipe elbow and vertically position the transmitter with the housing *below* the process connection.

Figure 22 - Hot Process Piping for Biplanar Transmitters

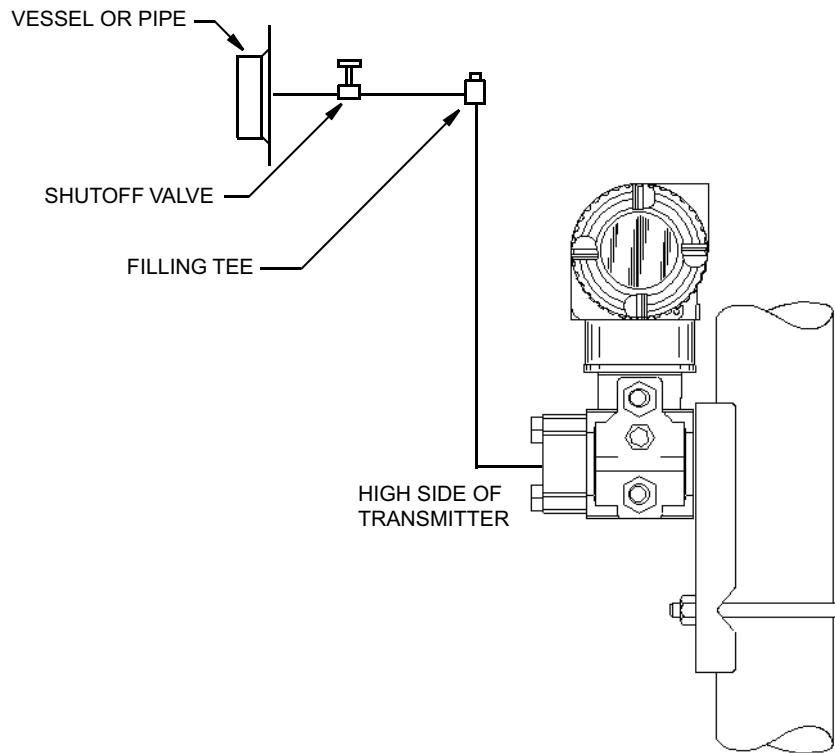

Additional Steps for Differential Pressure Transmitter Installation

Venting and Draining

Traditional Structure

Sensor cavity venting and draining is provided for both vertical and horizontal mounting.

- For vertically mounted units, draining is via a vent and drain screw. Venting is possible with side vents (option -V).
- For horizontally mounted units, the unit is self-draining. Venting is via a vent and drain screw.

Figure 23 - Vertical Mounting — Cavity Draining

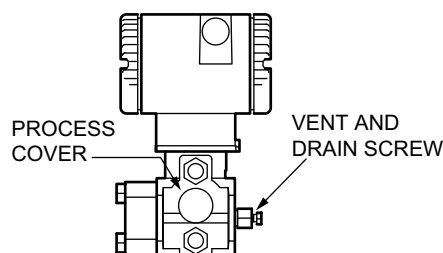

Figure 24 - Vertical Mounting — Cavity Venting

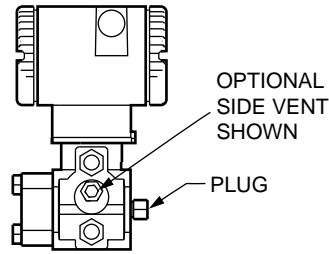
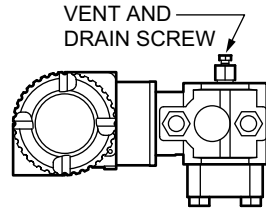

Figure 25 - Horizontal Mounting — Cavity Venting



LP1 Low Profile Structure

Sensor cavity venting and draining is provided for both vertical and horizontal mounting.

- For vertically mounted units, the transmitter is self-draining. Venting is via a vent and drain screw.
- For horizontally mounted units, the transmitter can simply be turned over (rotated 180 degrees) to orient the high and low pressure sides in the preferred locations. There is no need to unbolt the process covers.

If the transmitter is connected with a length of impulse piping, such piping should slope up to the transmitter for gas applications, or down for liquid applications.

Figure 26 - Vertical Mounting — Cavity Venting

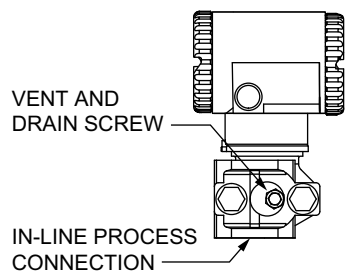
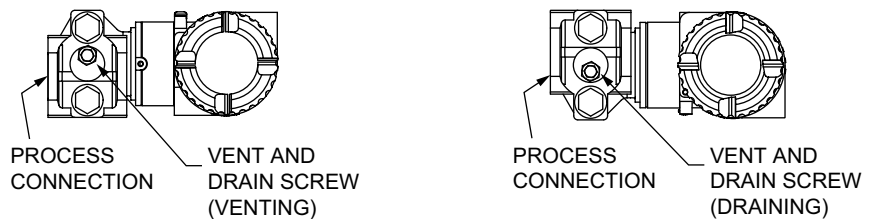

Figure 27 - Horizontal Mounting — Cavity Venting and Draining



LP2 Low Profile Structure

The LP2 low profile structure has a full-featured vent and drain design with separate vent and drain screws positioned in each cover for complete venting and draining from the sensor cavity.

Figure 28 - Cavity Venting and Draining

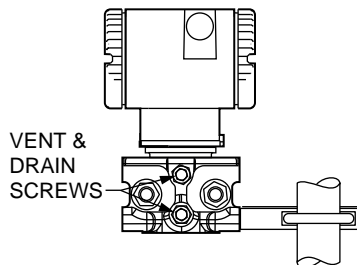

Installation of Flow Measurement Piping

Refer to the diagrams for typical installations with horizontal and vertical process pipes.

The transmitters are shown below the level of the pressure connections at the pipe (usual arrangement, except for gas flow without a seal liquid), and with filling tees in the lines to the transmitter (for a seal liquid).

If the process fluid being measured must not come into contact with the transmitter, the transmitter lines must be filled with a suitable seal liquid as described in *Filling the System with Seal Liquid, page 41*. In such a case, mount the transmitter below the level of the pressure connections at the pipe. With steam flow, the lines are filled with water to protect the transmitter from the hot steam. The seal liquid (or water) is added to the lines through the filling tees. To prevent unequal heads on the transmitter, the tees must be at the same elevation, and the transmitter must be mounted vertically as shown. If a seal liquid is not required, elbows can be used in place of the tees.

Tighten drain plugs and optional vent screws to 20 N-m (15 lbf-ft). Tighten the four process connector bolts to a torque of 61 N-m (45 lbf-ft).

The low and high pressure sides of the transmitter are identified by an L-H marking on the side of the sensor above the label.

With medium viscosity seal liquids and/or long transmitter lines, use larger valve sizes.

- With a **horizontal** line, pressure connections at the pipe should be at the side of the line. However, with gas flow without a seal liquid, connections should be at the top of the line.
- With a **vertical** line, flow should be upwards.
- For **liquid** or **steam** flow, the transmitter should be mounted lower than the pressure connections at the pipe.
- For **gas** flow *without* a seal liquid, the transmitter should be mounted higher than the pressure connections at the pipe.
- For **gas** flow *with* a seal liquid, the transmitter should be mounted lower than the pressure connections.
- It is recommended to use snubbers in installations prone to high levels of fluid pulsations.

Figure 29 - Example of Horizontal Process Line Installation

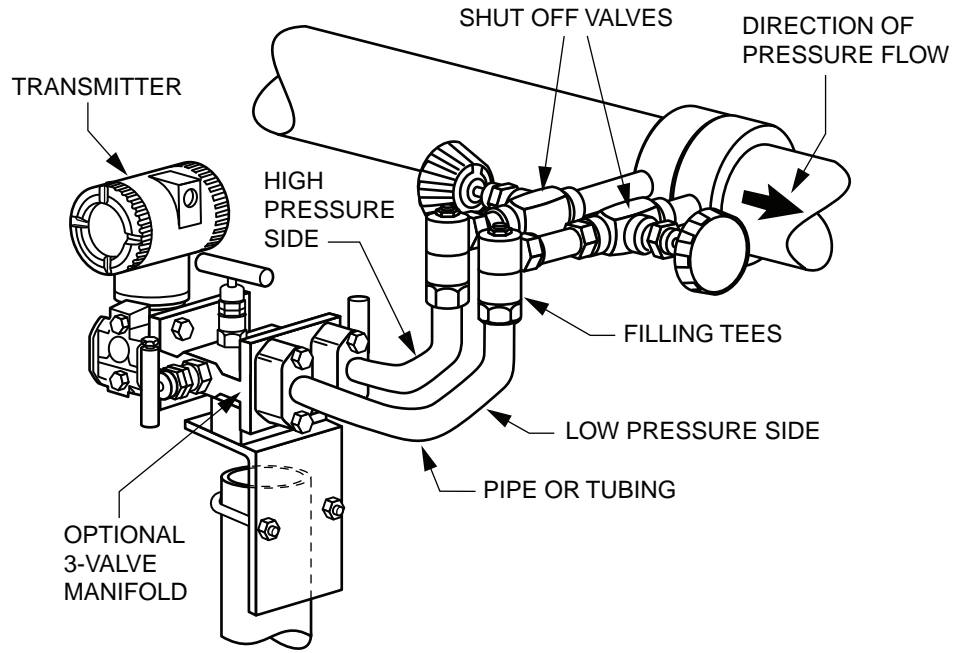
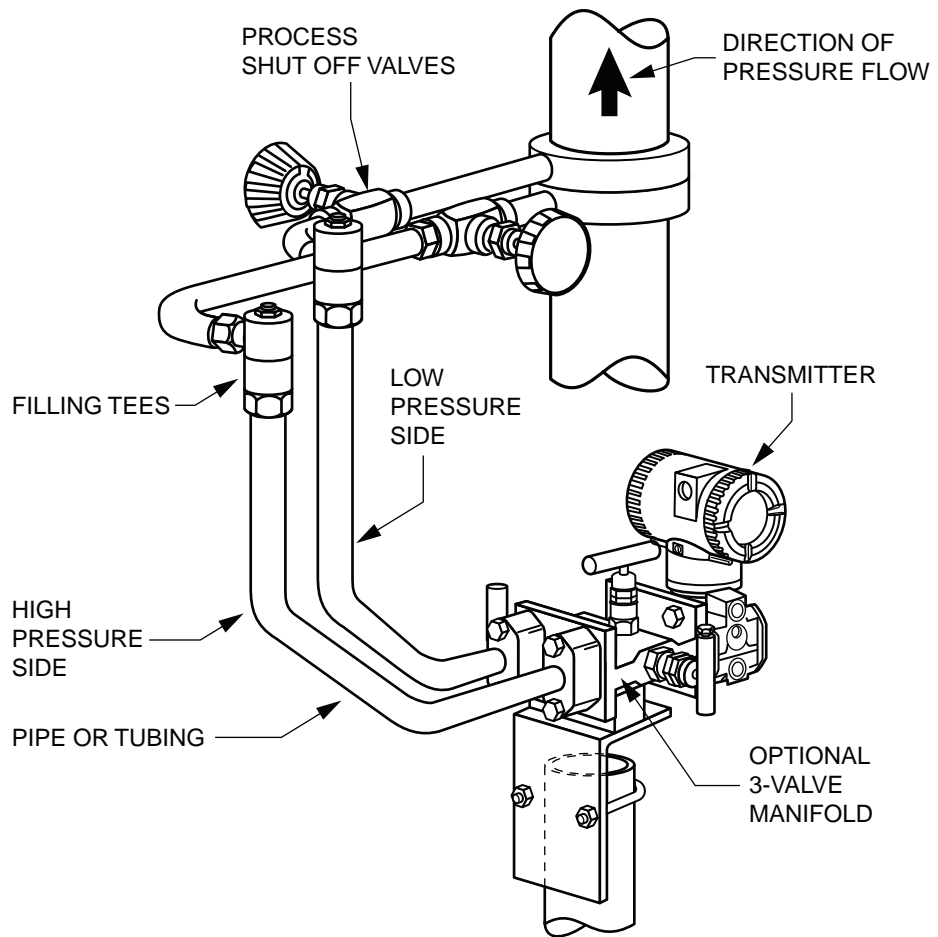

Figure 30 - Example of Vertical Process Line Installation



Filling the System with Seal Liquid

If the process fluid being measured must not come into contact with the transmitter, the transmitter lines must be filled with a suitable seal liquid as follows:

NOTICE

POTENTIAL EQUIPMENT DAMAGE AND PROCESS FLUID CONTAMINATION

To help prevent loss of seal liquid and contamination of process fluid, never open both process shutoff valves and manifold shutoff valves if the bypass valve is open.

Failure to follow these instructions can result in equipment damage and process fluid contamination.

1. If the transmitter is in service, follow the procedure in *Taking a Differential Pressure Transmitter out of Operation*, page 49.
2. Close both process shutoff valves.
3. Open all three valves on the 3-valve manifold.
4. Partially open the vent screws on the transmitter until all air has been forced out of the transmitter body and lines. Close the vent screws.
5. Refill the tee connections. Replace the plugs and close the bypass valve. Check for leaks.
6. Follow the procedure in *Putting a Differential Pressure Transmitter into Operation*, page 49.

Positioning the Housing

The transmitter housing (topworks) can be rotated up to one full turn in the counterclockwise direction when viewed from above for optimum access to adjustments, display, or conduit connections. The housing has a retention clip that keeps the housing from being rotated beyond a safe depth of housing/sensor thread engagement.

NOTICE

POTENTIAL VIBRATION EFFECTS

If you remove the housing for maintenance, do not over-tighten it upon reassembly. Hand-tighten it to the bottom of the threads, then back off a half-turn counterclockwise to avoid bottoming out the housing to the sensor.

Failure to follow these instructions can result in amplified vibration effects.

Figure 31 - Housing Clip Location

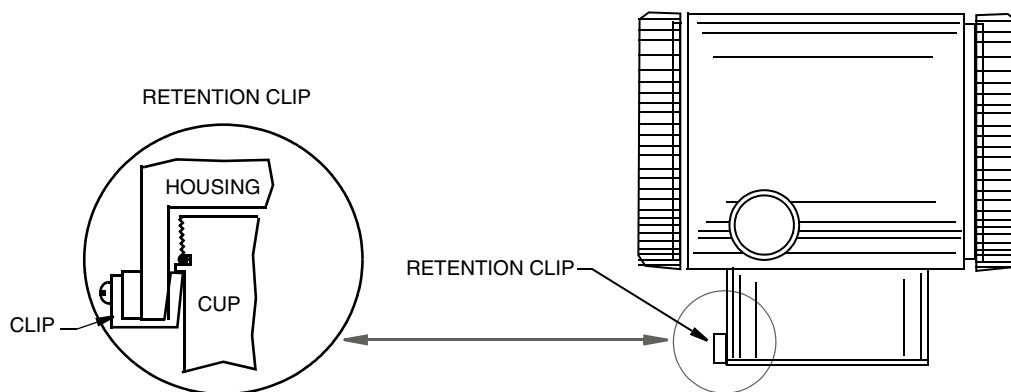

Positioning the Display

The optional display can be rotated within the housing at 90° increments to any of four positions. To do this, grasp the two tabs on the display and rotate it about 10° in a counterclockwise direction. Pull out the display. Ensure that the o-ring is fully seated in its groove in the display housing. Turn the display to the desired position, reinsert it in the electronics module, aligning the tabs on the sides of the assembly, and twist it in the clockwise direction.

NOTICE

POTENTIAL EQUIPMENT DAMAGE

Do not turn the display more than 180° in any direction. Doing so can damage its connecting cable.

Failure to follow these instructions can result in equipment damage.

Setting the Write Protect Jumper

Your transmitter has write protection capability. This means that the external zero, local display, and remote communications can be prevented from writing to the electronics. Enable write protection by moving a jumper that is located in the electronics compartment behind the optional display.

To activate write protection, remove the display as described in *Positioning the Display, page 42*, then remove the jumper or move it to the lower position as shown on the exposed label. Replace the display.

Figure 32 - Write Protect Jumper

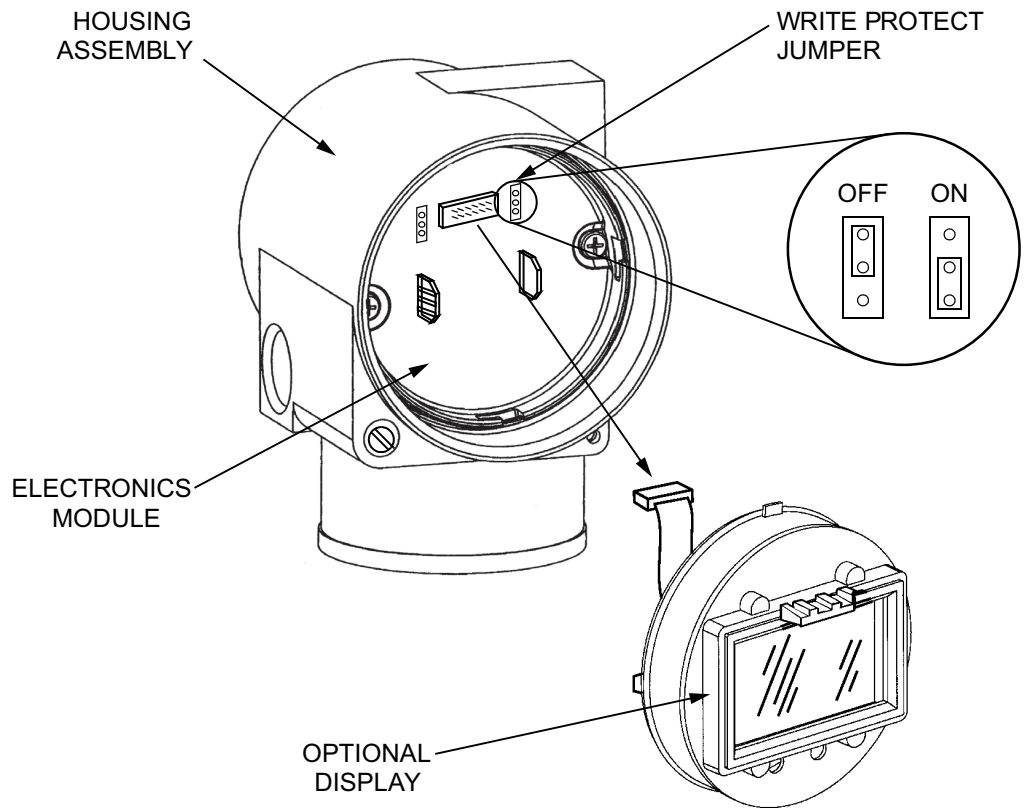

Cover Locks

Housing cover locks are provided as standard with certain agency certifications and as part of the Custody Transfer Lock and Seal option. To lock the covers, unscrew the locking pin until approximately 6 mm (0.25 in) shows, lining up the hole in the pin with the hole in the housing. Insert the seal wire through the two holes, slide the seal onto the wire ends, and crimp the seal.

Figure 33 - Cover Lock Location

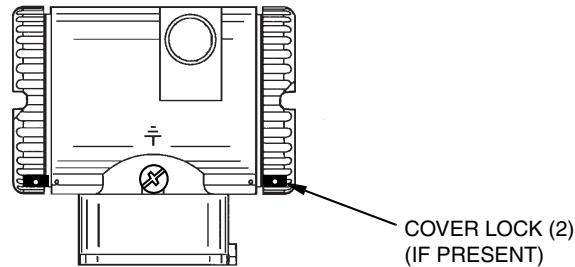

Wiring

The installation and wiring of your transmitter must conform to local code requirements.

⚠ WARNING

EXPLOSION HAZARD

ATEX requires that when equipment is intended to be used in an explosive atmosphere caused by the presence of combustible dust, cable entry devices and blanking elements must provide a degree of ingress protection of at least IP6X. They must be suitable for the conditions of use and correctly installed.

Failure to follow these instructions can result in death, serious injury, or equipment damage.

NOTE: Use transient/surge protection in installations prone to high levels of electrical transients and surges.

Accessing Transmitter Field Terminals

For access to the field terminals, thread the cover lock (if present) into the housing to clear the threaded cover, and remove the cover from the field terminals compartment as shown.

Figure 34 - Accessing Field Terminals

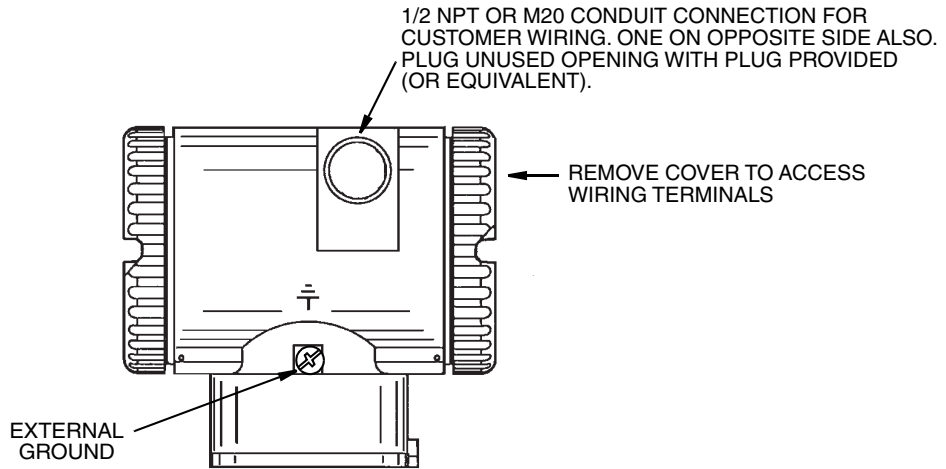
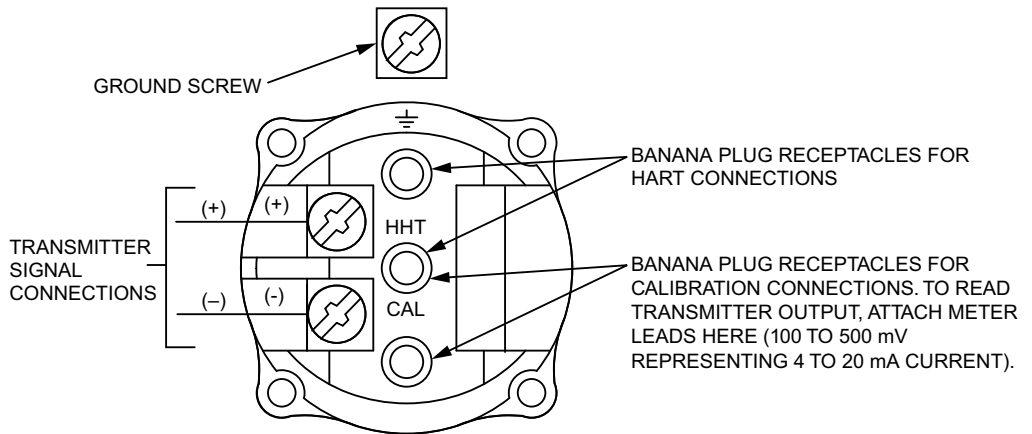

Figure 35 - Identification of Field Terminals



Wiring the Transmitter to a Control Loop

When wiring the transmitter, the supply voltage and loop load must be within specified limits. The supply output load vs. voltage relationship, shown in the following graph, is $R_{max} = 47.5 (V - 12.5 \text{ V dc})$.

You can use any combination of supply voltage and loop load resistance in the shaded area shown in *Supply Voltage and Loop Load*, page 46. To determine the loop load resistance (transmitter output load), add the series resistance of each component in the loop, excluding the transmitter. The power supply must be capable of supplying 22 mA of loop current.

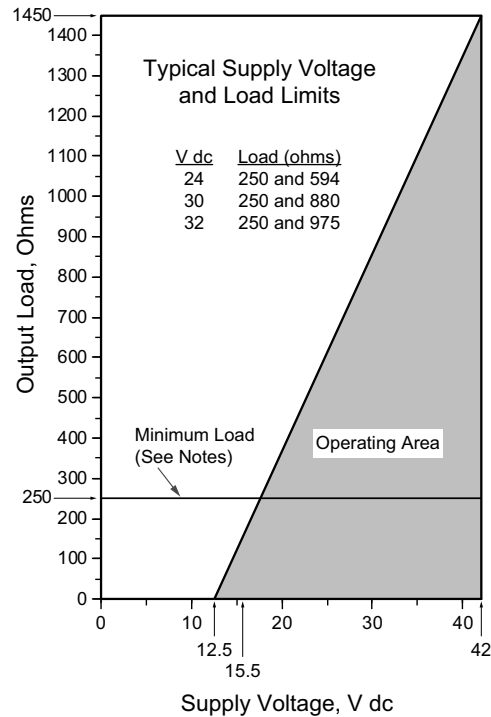
Figure 36 - Supply Voltage and Loop Load**NOTES:**

1. The minimum voltage for HART communication is 15.5 V dc.
2. The minimum load for the HART Communicator is 250 ohms.
3. The transmitter can function with an output load less than the minimum, but using a remote configurator while operating in this area will result in output and/or communication disturbances.

Examples:

- For a loop load resistance of 880 Ω , the supply voltage can be any value from 30 to 42 V dc.
- For a supply voltage of 24 V dc, the loop load resistance can be any value from 250 to 594 Ω (0 to 594 Ω without a HART communicator or PC-based configurator connected to the transmitter).

To wire one or more transmitters to a power supply, follow these steps:

1. Remove the cover from the transmitter field terminals compartment.
2. Run signal wires (0.50 mm² or 20 AWG, typical) through one of the transmitter conduit connections. Use twisted single pair to help protect the 4 to 20 mA output and/or remote communications from electrical noise. The maximum recommended length for signal wires is:
 - 3,050 m (10,000 ft) using single pair cable and adhering to the requirements of the HART physical layer implementation defined in HART Document HCF_SPEC-53. Use CN=1 when calculating maximum lengths.
 - 1,525 m (5,000 ft) in multidrop mode. Shielded cable could be required in some locations.

NOTE: Do not run the transmitter wires in the same conduit as the mains (ac power) wires.
3. If shielded cable is used, ground the shield at the power supply only. Do not ground the shield at the transmitter.

- Plug the unused conduit connection.

⚠ ⚠ WARNING
EXPLOSION HAZARD
To help prevent possible explosions and to maintain flameproof, explosionproof, and dust-ignitionproof protection, observe applicable wiring practices. Plug the unused conduit openings with approved conduit plugs. Both plug and conduit must engage a minimum of five full threads for 1/2 NPT connections; seven full threads for M20 connections.
Failure to follow these instructions can result in death or serious injury.

- Connect a ground wire to the ground terminal in accordance with local practice.

NOTICE
POTENTIAL REDUCED PERFORMANCE OR EQUIPMENT DAMAGE
If the signal circuit must be grounded, it is preferable to ground it at the negative terminal of the dc power supply. To avoid errors resulting from ground loops or the possibility of short-circuiting groups of instruments in a loop, there should be only one ground in a loop.
Failure to follow these instructions can result in reduced performance or equipment damage.

- Connect the power supply and receiver loop wires to the “+” and “-” terminal connections.
- Connect receivers (such as controllers, recorders, indicators) in series with the power supply and transmitter as shown in the diagram.

Figure 37 - Loop Wiring Transmitters

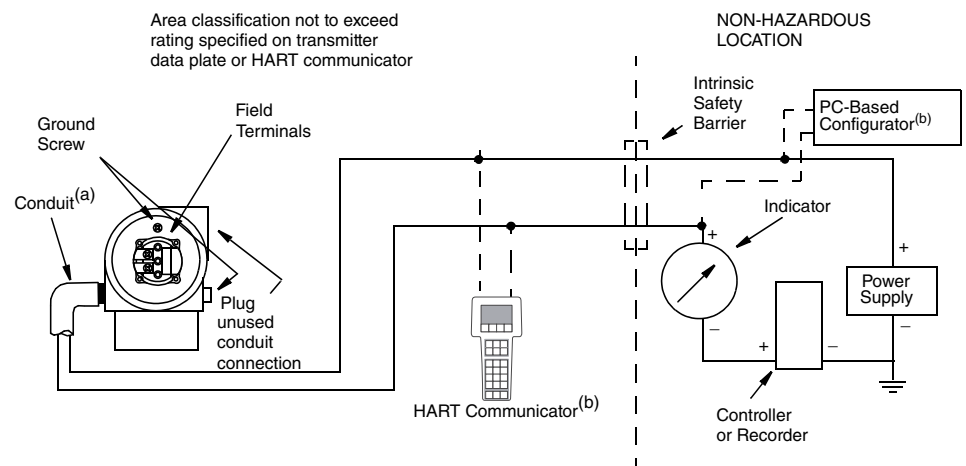

(a) Run conduit down to avoid moisture buildup in terminals compartment.
 (b) There must be at least 250 ohms total resistance between the HART communicator or PC-based configurator and the power supply.

- Reinstall the cover onto the housing by rotating it clockwise to seat the o-ring into the housing, then continue to hand-tighten until the cover contacts the housing metal-to-metal. If cover locks are present, lock the cover as described in *Cover Locks, page 44*.

- To wire additional transmitters to the same power supply, repeat these steps for each transmitter. The setup for multiple transmitters connected to a single power supply is shown in the next diagram.

Figure 38 - Wiring Several Transmitters to a Common Power Supply

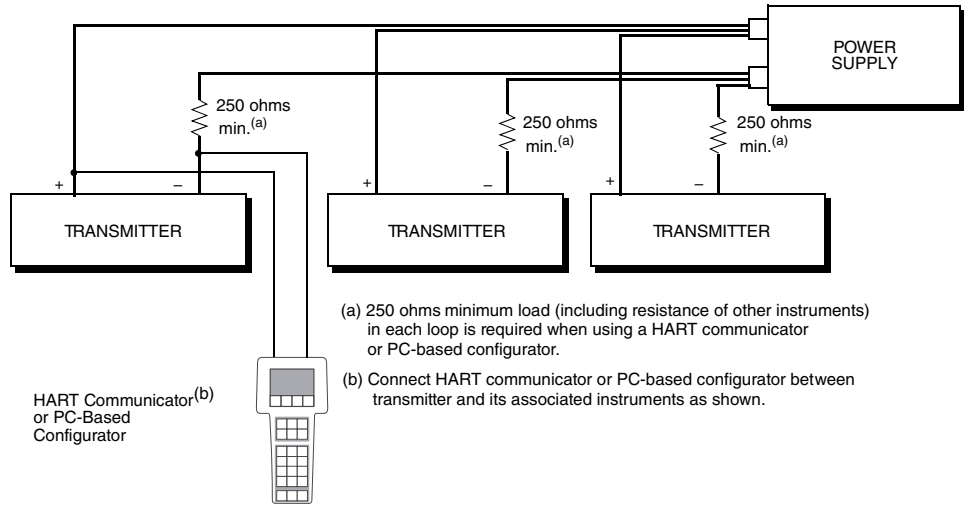

- A HART communicator or PC-based configurator can be connected in the loop between the transmitter and the power supply as shown in *Loop Wiring Transmitters, page 47* and *Wiring Several Transmitters to a Common Power Supply, page 48*. A minimum of 250 Ω must separate the power supply from the HART communicator and PC-based configurator.

Multidrop Communication

“Multidrop communication” refers to the connection of several transmitters to a single communications transmission line. Communications between the host computer and the transmitters takes place digitally with the analog output of the transmitter deactivated. With the HART communications protocol, up to 64 transmitters can be connected on a single twisted pair of wires or over leased telephone lines.

The application of a multidrop installation requires consideration of the update rate necessary from each transmitter, the combination of transmitter models, and the length of the transmission line. Communication with the transmitters can be accomplished with any HART compatible modem and a host implementing the HART protocol. Each transmitter is identified by a unique address (0 through 63) and responds to the commands defined in the HART protocol.

Typical Multidrop Network, page 48 shows a typical multidrop network. Do not use this figure as an installation diagram. Contact the FieldComm Group (<http://www.fieldcommgroup.org>) for specific requirements for multidrop applications.

Figure 39 - Typical Multidrop Network

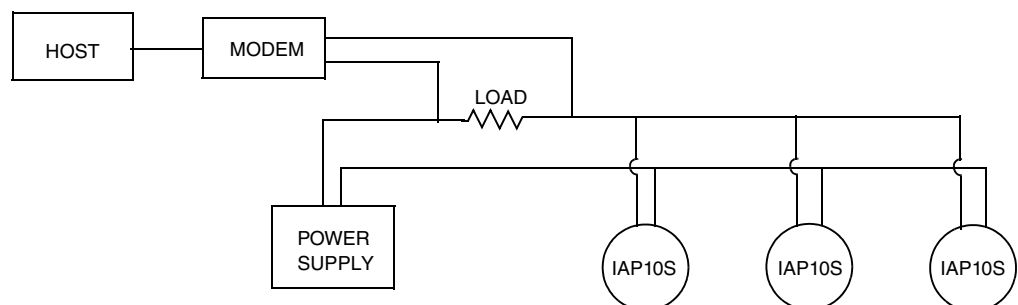

The HART Communicator can operate, configure, and calibrate pressure transmitters with HART communication protocol the same way it can in a standard point-to-point installation.

NOTE:

The transmitters are shipped from the factory with a poll address of 0 and with the loop current mode set to “enabled” (active), allowing the transmitters to operate in a standard point-to-point manner with a 4 to 20 mA output signal.

To activate multidrop communication, assign each transmitter a unique address (0 through 63) on each multidrop network. However, changing the transmitter poll address does not automatically deactivate the 4 to 20 mA analog output.

Only one device per multidrop network can be configured with loop current enabled. To fix the mA output value, set the loop current mode to “disabled.”

Connecting the Transmitter to a Schneider Electric Distributed Control System

The transmitter can also send its measurement to a Schneider Electric distributed control system as a digital signal via an FBM214/215. Wiring terminations at the transmitter are the same as described in this section. For other system wiring details, refer to the installation instructions provided with the DCS.

Putting a Differential Pressure Transmitter into Operation

This procedure explains how to sequence the valves in your flow measurement piping or optional bypass manifold to help ensure that your transmitter is not overranged and that seal liquid is not lost. Refer to the diagrams in *Installation of Flow Measurement Piping*, page 39.

NOTE: This procedure assumes that the process shutoff valves are open.

1. Make sure that both upstream and downstream manifold valves are closed.
2. Make sure that the bypass valve is open.
3. After installing the transmitter, slowly open the upstream manifold valve.
4. Close the bypass valve.
5. Slowly open the downstream manifold valve.

Taking a Differential Pressure Transmitter out of Operation

This procedure explains how to sequence the valves in your flow measurement piping or optional bypass manifold to help ensure that your transmitter is not overranged and that seal liquid is not lost. Refer to the diagrams in *Installation of Flow Measurement Piping*, page 39.

NOTE: This procedure assumes that the process shutoff valves are open.

1. Close the downstream manifold valve.
2. Close the upstream manifold valve.
3. Open the bypass valve.

- Carefully open the vent screw to release any residual pressure before disconnecting lines.

▲ WARNING

RISK OF EXPOSURE

When venting pressure from the transmitter, wear suitable protective equipment to prevent possible injury from process material, temperature, or pressure.

Failure to follow these instructions can result in death or serious injury.

- Remove the transmitter, if applicable.

Operation with the Local Display

The local display provides local indication of measurement information on two lines. The upper line displays five digits (four digits when a minus sign is needed); the lower line displays seven alphanumeric characters.

During normal transmitter operation, the display shows either the primary measurement (M1) or secondary measurement (M2), depending on how you configure the transmitter.

- If configured as **Show 1**, the display shows the primary measurement value (M1) and the configured units.
- If configured as **Show 2**, the display shows the secondary measurement value (M2) and the configured units.
- To temporarily view the alternate measurement, press the **ENTER** button. The alternate measurement briefly appears on the display, and then the display reverts to the configured measurement.
- If configured as **Toggle**, the display toggles between the primary (M1) and secondary (M2) measurements. When M2 is displayed, the digit **2** blinks in the lower right corner of the display.

NOTE:

- If the displayed measurement is more than five digits, “99999” flashes on the display. Selecting different engineering units (EGUs) may result in a shorter measurement that can fit on the display.
- For AP transmitters, “a” is typically added to the EGU name on the display (for example, **psia** or **mmHga**). However, if the EGU name is six characters long, the “a” is not added.

Figure 40 - Local Display

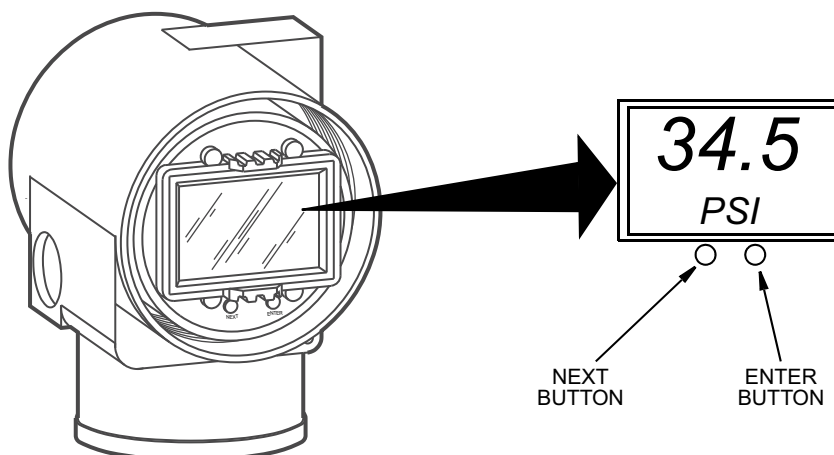

The display and two-button keypad on the front of the transmitter also provide access to calibration, configuration, and other functions. You can access these operations by means of a menu system. To access the multi-level menu from the transmitter’s normal operating mode, press **NEXT**. To exit this menu, cancel your calibration or configuration, and return to the normal operating mode at any time, navigate to **Cancel** and press **ENTER**.

Figure 41 - Top Level Menu

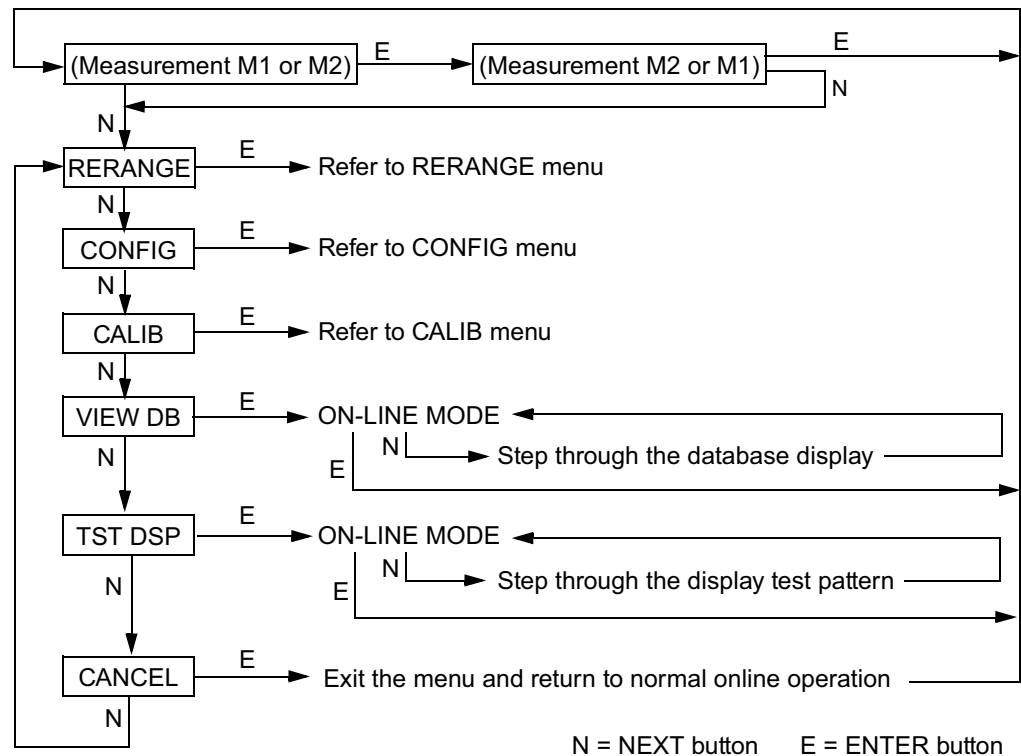

Entering Strings and Numeric Values

To enter strings or numeric values, follow these steps:

1. At the appropriate prompt, press the **ENTER** button. The display shows the last (or default) value with the first character flashing.
2. Use the **NEXT** button to select the first character, then press **ENTER**.
Your selection is entered. The next character flashes.
3. Repeat the previous step until you have entered all five characters. If your string or value has fewer than five characters, use leading or trailing zeroes in the remaining positions, if required.
When you have entered the fifth character, the display prompts you to place the decimal point.
4. Select the desired decimal point location by pressing **NEXT** until the decimal point is placed as desired. Press **ENTER**.

NOTE:

- You cannot place the decimal point immediately after the first digit. For example, you cannot enter a value as 1.2300; you must enter it as 01.230.
- The decimal position is identified by flashing, except at the position after the fifth digit. At that position, a whole number is represented, and the decimal point is assumed.

The display advances to the next menu item.

Table 10 - Permitted Characters for the Local Display

Alphanumeric Characters		Numeric Characters
@	,	
, (comma)	(
A-Z (uppercase))	- (minus sign)
a-z (lowercase)	*	. (decimal point)
[+	0
]	- (hyphen)	1
\	. (period)	2
^	/	3
_ (underscore)	0-9	4
(space)	:	5
!	;	6
"	<	7
#	>	8
\$	=	9
%	?	
&		

Reranging

Since the transmitter continuously determines an internal digital value of the measured pressure from the lower range limit (LRL) to the upper range limit (URL), the 4 and 20 mA output points can be assigned to any pressure values within the span and range limits, without the application of pressure.

- Reranging does not affect the calibration of the transmitter; that is, it does not affect the optimization of the internal digital value of pressure over a specific calibrated range.
- If the reranged LRV and URV are not within the calibrated range, the measured values may not be as accurate as when the LRV and URV are within the calibrated range.
- If you need to perform a span calibration after reranging the transmitter, be sure to perform an offset calibration (**Cal LRV**) before performing the span calibration (**Cal URV**) operation. If you do not perform the offset calibration, you may get a **BADSPAN** message.
- For DP transmitters, if **M1 MODE** is in a square root mode, regardless of engineering units selected, **RERANGE** is done in the following pressure units:
 - **inH2O**, if **M2 MODE** is a type of square root with span range code B or C.
 - **psi**, if **M2 MODE** is a type of square root with span range code D or E.
 - **M2_EGU** units, if **M2 MODE** is linear with all span range codes.

During **RERANGE**, the bottom line of the display indicates the units that are in use. After **RERANGE**, the display automatically returns to the configured engineering units.

You can rerange the transmitter by entering new database values for the LRV and URV.

1. With the transmitter in normal operating mode, press the **NEXT** button to access the transmitter's top level menu. The first menu item is **RERANGE**. Press **ENTER** to select it.
2. Use the procedure in *Entering Strings and Numeric Values, page 52* to adjust **M1_URV** and/or **M1_LRV** as desired.
 - To edit the upper range value, press **ENTER** at the **M1_URV** prompt.
 - To edit the lower range value, press **ENTER** at the **M1_LRV** prompt.

NOTE: For DP transmitters, **M1_LRV** is bypassed if **M1 MODE** is configured as square root, because **M1_LRV** must be zero.

Figure 42 - Rerange Menu Diagram

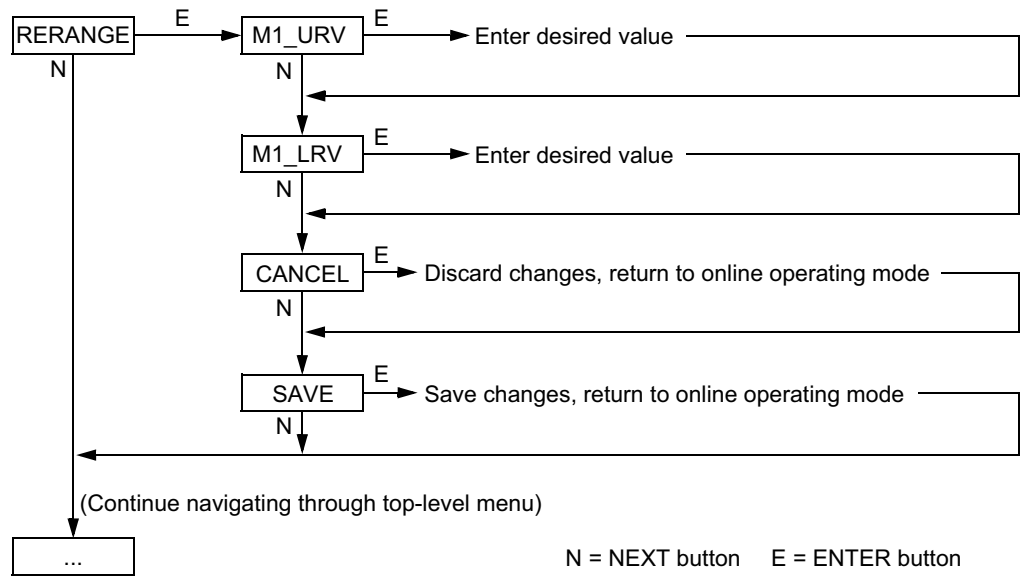

Viewing the Database

You can view the database using the multi-level menu system.

1. From the transmitter's normal operating mode, press the **NEXT** button to access the transmitter's top level menu.
2. Navigate to **VIEW DB**, then press **ENTER**. The display shows the first item in the database, **FMW REV**.
3. Continue stepping through the database by pressing **NEXT**, or exit the database view by pressing **ENTER**.

The following diagram shows the VIEW DB menu. The database items are described in *Transmitter Database Items, page 56*.

Figure 43 - VIEW DB Menu

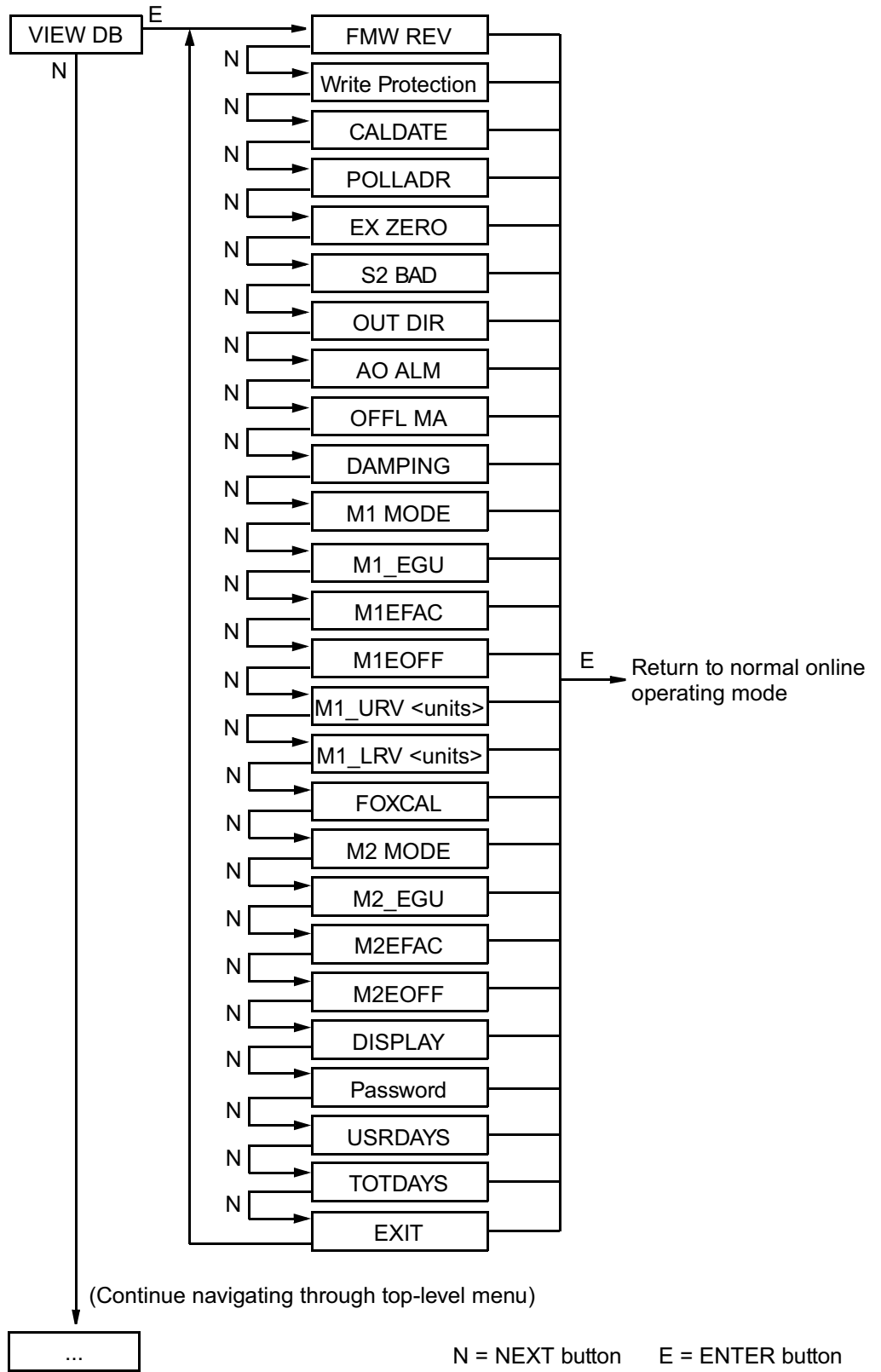

Table 11 - Transmitter Database Items

Database Item	Available Settings or Example
Firmware Revision (FMW REV)	2.0 (example)
write protection status (no parameter label)	WP DISA (disabled) WP ENA (enabled)
Date of Last Calibration (CALDATE)	01JAN18 (example)
Poll Address (POLLADR)	0 through 63
External Zero Status (EX ZERO)	EXZ ENA (enabled) EXZ DIS (disabled)
Temperature Sensor Strategy (S2 BAD)	AO ALM USE DEF
4 to 20 mA Output Direction (OUT DIR)	OUT FWD (forward) OUT REV (reverse)
4 to 20 mA Output Alarm Mode (AO ALM)	LO ALM (low) HI ALM (high)
4 to 20 mA Output in Offline Mode (OFFL MA)	LAST_MA (last) 4.000 (user-set example)
Damping, in Seconds (DAMPING)	DAMP0, DAMP1/4, DAMP1/2, DAMP1, DAMP2, DAMP4, DAMP8, DAMP16, DAMP32
M1 Mode Output (M1 MODE)	Linear: M1 LIN Type of square root: ⁴⁰ M1SQ<1C, M1SQ<4L, M1SQ<nC
Engineering Units for M1 (M1_EGU)	Linear: inH2O, ftH2O, mmH2O, inHg, mmHg, cmHg, mHg, psi, psf, mbar, bar, g/cm2, kg/cm2, kg/m2, Pa, hPa, kPa, MPa, torr, inWC60, ftWC60, inWC4, ftWC4, mmWC4, cmWC4, mWC4, atm, dy/cm2 Square root: ⁴⁰ gal/s, gal/m, gal/h, gal/d, Mgal/d, ft3/s, ft3/m, ft3/h, ft3/d, lgal/s, lgal/m, lgal/h, lgal/d, l/s, l/m, l/h, Ml/d, m3/s, m3/m, m3/h, m3/d, Nl/h, Nm3/h, Sm3/h, Am3/h, Sft3/m, MSCFD, MMSCFD, bbl/s, bbl/m, bbl/h, bbl/d, g/s, g/m, g/h, kg/s, kg/m, kg/h, kg/d, lb/s, lb/m, lb/h, lb/d, t/m, t/h, t/d, STon/m, STon/h, STon/d, LTon/h, LTon/d, %flow
M1 Engineering Factor (M1EFAC)	30.000 (example)
Offset Applied to the Primary Value (M1EOFF)	0.000 (example)
Primary Upper Range Value (M1_URV <units>)	30.000 (example)
Primary Lower Range Value (M1_LRV <units>)	0.000 (example)
Status of FoxCal™ Multiple Calibration (FOXCAL) ⁴¹	FCALON (FoxCal™ on) FCALOFF (FoxCal™ off)
M2 Mode Output (M2 MODE)	Linear: M1 LIN Type of square root flow calculation: ⁴⁰ M2SQ<1C (cutoff below 1% of the calibrated differential <i>pressure</i> range) M2SQ<4L (linear extrapolation below 4% of the calibrated differential <i>pressure</i> range) M2SQ<nC (user-defined cutoff specified between 0 and 20% of the <i>flow</i> upper range value, M2EFAC)

40. Differential pressure transmitters only.

41. FoxCal™ is available with the Advanced (10S) and Premium (50S) Performance tiers only.

Table 11 - Transmitter Database Items (Continued)

Database Item	Available Settings or Example
Engineering Units for M2 (M2_EGU)	Linear: inH2O, ftH2O, mmH2O, inHg, mmHg, cmHg, mHg, psi, psf, mbar, bar, g/cm2, kg/cm2, kg/m2, Pa, hPa, kPa, MPa, torr, inWC60, ftWC60, inWC4, ftWC4, mmWC4, cmWC4, mWC4, atm, dy/cm2 Square root: ⁴² gal/s, gal/m, gal/h, gal/d, Mgal/d, ft3/s, ft3/m, ft3/h, ft3/d, lgal/s, lgal/m, lgal/h, lgal/d, l/s, l/m, l/h, Ml/d, m3/s, m3/m, m3/h, m3/d, NI/h, Nm3/h, Sm3/h, Am3/h, Sft3/m, MSCFD, MMSCFD, bbl/s, bbl/m, bbl/h, bbl/d, g/s, g/m, g/h, kg/s, kg/m, kg/h, kg/d, lb/s, lb/m, lb/h, lb/d, t/m, t/h, t/d, STon/m, STon/h, STon/d, LTon/h, LTon/d, %flow
M2 Engineering Factor (M2EFAC)	1000.0 (example) ⁴²
Offset Applied to the Secondary Value (M2EOFF)	0.000 (example)
Measurement(s) shown on the display (DISPLAY)	SHOW M1 (primary measurement) SHOW M2 (secondary measurement) TOGGLE (toggle between primary and secondary measurements)
Current Password Setting	NO PWDS (no password) ENA PWD (enable password) CFGONLY (configuration only) CFG+CAL (configuration and calibration)
Number of days the transmitter has been running since the Time In Service Meter was reset (USRDAY s)	7 (example)
Number of days the transmitter has been running since it was installed (TOTDAY s)	61 (example)

Testing the Display

You can use the multi-level menu system to test the transmitter display. Follow these steps:

1. From the transmitter's normal operating mode, press **NEXT** to access the transmitter's top level menu.
2. Press **NEXT** to navigate to **TST DSP** and press **ENTER**. The display shows the first test segment pattern.
3. Step through the five test patterns by pressing **NEXT** repeatedly. Refer to the diagram.
4. Exit the display test by pressing **ENTER**.

⁴². Differential pressure transmitters only.

Figure 44 - Display Test Segment Patterns

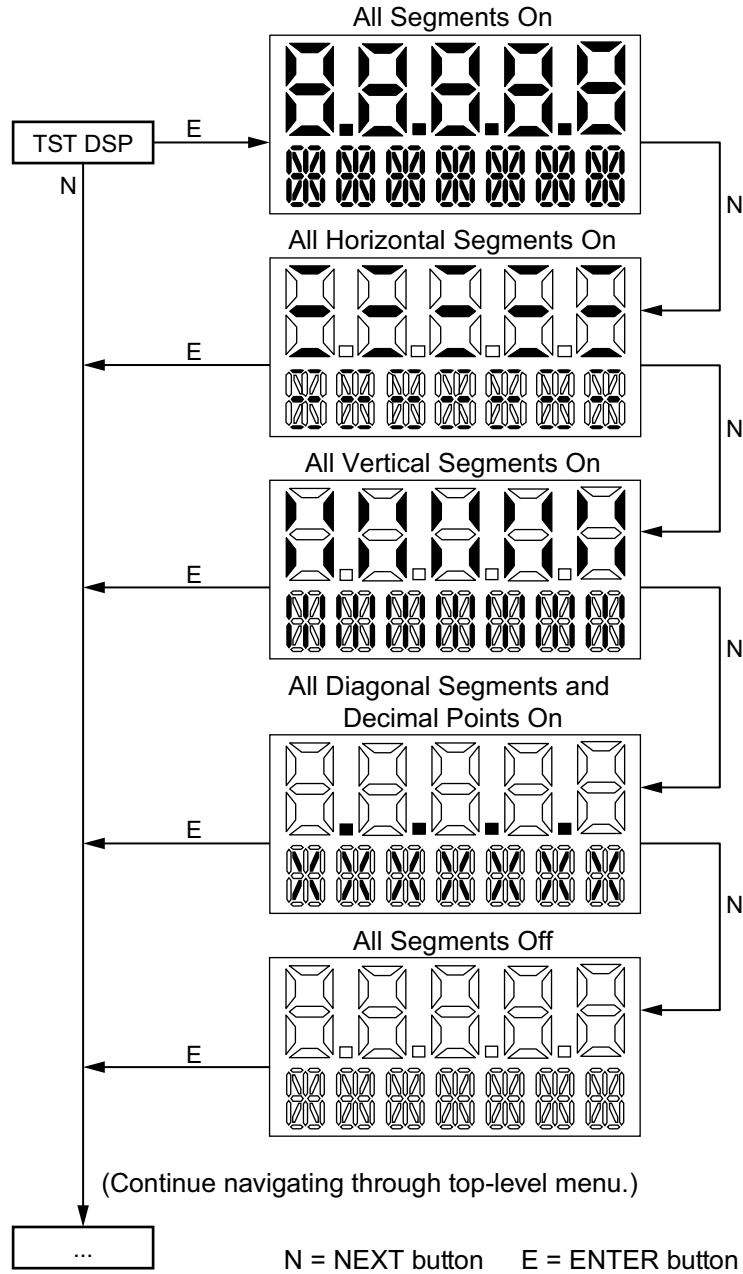

Messages

The following operation-related messages may appear on the display.

Status	Condition Tested	Message	Description
Startup	Database corruption	INITBAD	Perform a SET GDB procedure.
Normal operation	Write protection enabled	WR PROT	Displays periodically to notify that unit is write protected.
	Any non-online condition	OFFLINE	Notifies of a non-online condition.
Measurement outside of limits	Pressure	IN1 BAD	<ul style="list-style-type: none"> • Extreme overrange or underrange input; correct input condition. • Bad calibration; recalibrate transmitter. • Bad sensor connection; check electronics module to sensor. • Inoperative sensor.
	Electronics temperature	IN2 BAD	<ul style="list-style-type: none"> • Bad sensor connection; check electronics module connection to sensor.
	Sensor (process) temperature	IN3 BAD	<ul style="list-style-type: none"> • Inoperative sensor.

Configuration

You can configure the transmitter by accessing the menu system using the **ENTER** and **NEXT** buttons on the local display, or by using a remote configurator.

If your transmitter was ordered with optional feature -C2, the factory default values were customized.

Configuration Using the Optional Local Display

To access configuration mode from normal operating mode, repeatedly press the **NEXT** button until the display reads **CONFIG**. Press the **ENTER** button to select **CONFIG**. The display shows the first item in the Configuration menu.

NOTE:

- The standard factory default configuration is not used if model code option -C2 was specified for the order. Option -C2 is a custom factory configuration to user specifications.
- You can configure most parameters using the local display. For more complete configuration capability, use a HART communicator or PC-based configurator.
- During configuration, a single change could affect several parameters. For this reason, if you make a mistake, review the entire database. Or, use the **CANCEL** feature to restore the transmitter to its starting configuration and begin again.

Proceed to configure your transmitter by using the **NEXT** and **ENTER** buttons to make your selections. Refer to the menu structure diagrams and accompanying table for guidance.

At any time during the configuration, you can **CANCEL** your changes and return to online mode, or **SAVE** your new configuration.

NOTE: During configuration, the transmitter is in offline mode, and output is set to offline mA.

Configuration Menu Structure — AP and GP Transmitters

Figure 45 - Configuration Menu Structure, AP and GP Transmitters (1 of 3)

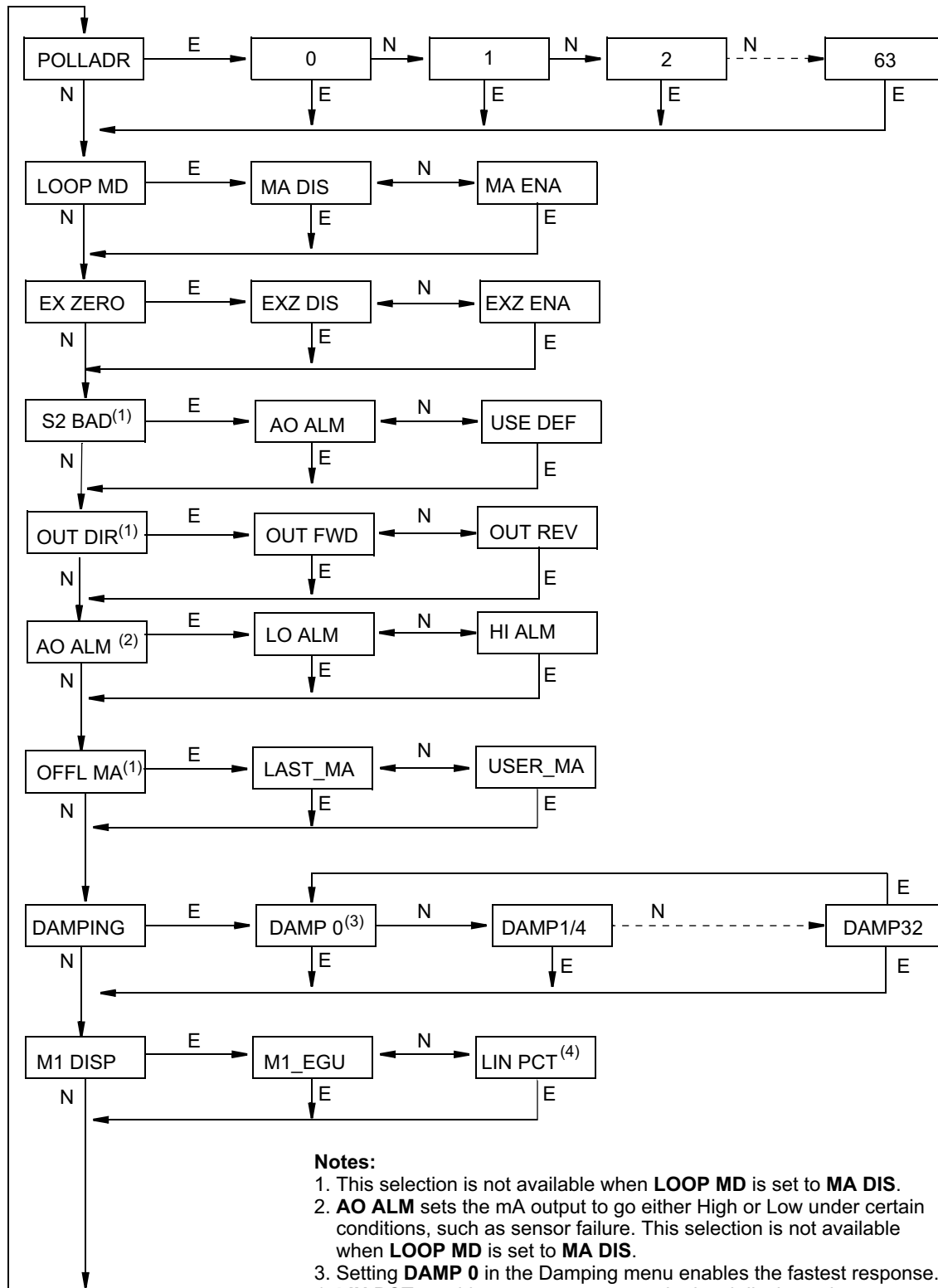

Notes:

1. This selection is not available when **LOOP MD** is set to **MA DIS**.
2. **AO ALM** sets the mA output to go either High or Low under certain conditions, such as sensor failure. This selection is not available when **LOOP MD** is set to **MA DIS**.
3. Setting **DAMP 0** in the Damping menu enables the fastest response.
4. **LIN PCT** provides percent output on the local display only.

Continued on next page

Figure 46 - Configuration Menu Structure, AP and GP Transmitters (2 of 3)

Continued from previous page

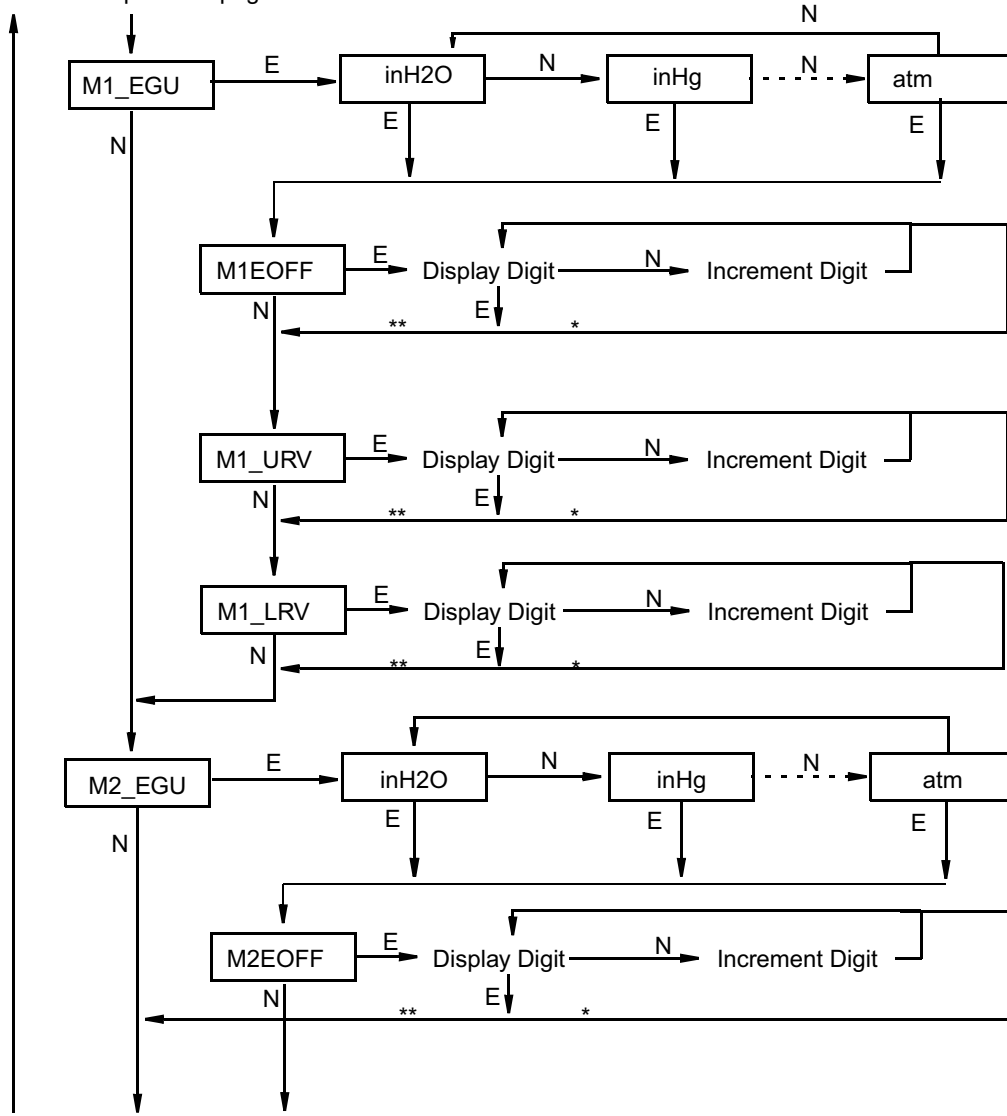

Continued on next page

Notes:

- * If character is not the last position on the display line, advances to the next character.
- ** If character is the last position on the display line, advances to the next menu item.

Figure 47 - Configuration Menu Structure, AP and GP Transmitters (3 of 3)

Continued from previous page

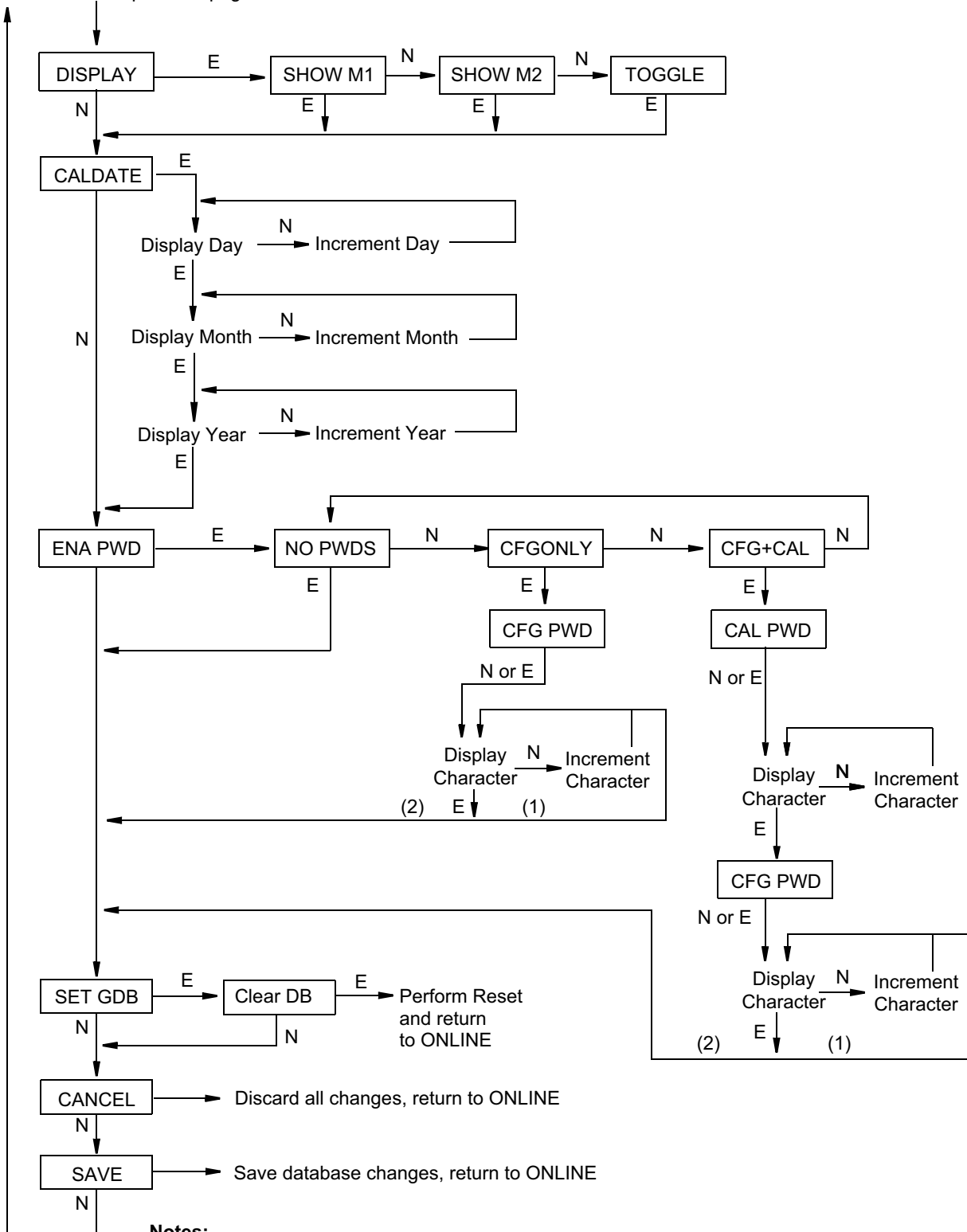

Notes:

1. If character is not the last position on the display line, advances to the next character.
2. If character is the last position on the display line, advances to the next menu item.

Configuration Menu Structure — DP Transmitters

Figure 48 - Configuration Menu Structure, DP Transmitters (1 of 4)

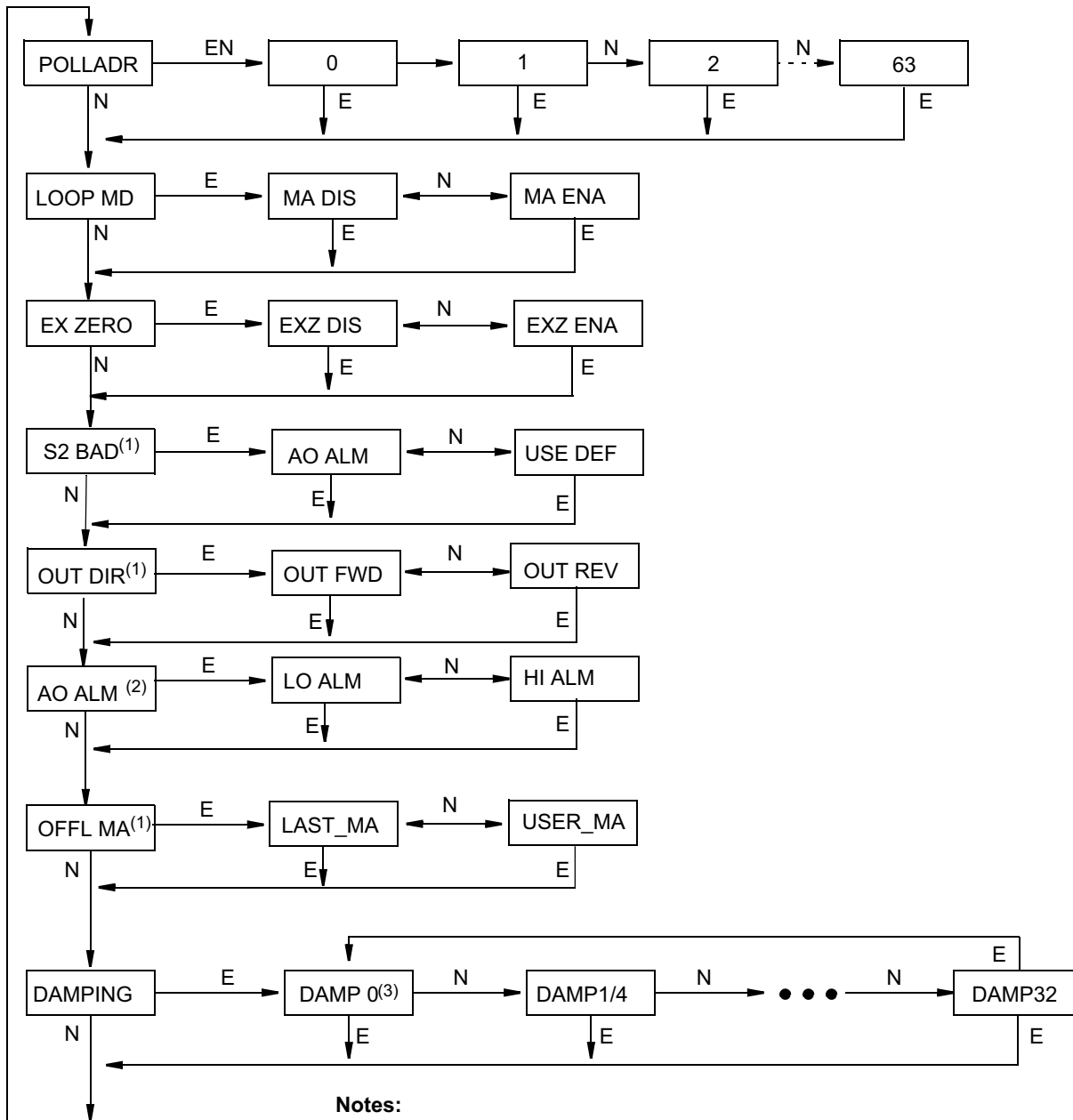

Continued on next page

Notes:

1. This selection is not available when **LOOP MD** is set to **MA DIS**.
2. **AO ALM** sets the mA output to go either High or Low under certain conditions, such as sensor failure. This selection is not available when **LOOP MD** is set to **MA DIS**.
3. Setting **DAMP 0** in the damping menu enables the fastest response.

Figure 49 - Configuration Menu Structure, DP Transmitters (2 of 4)

Continued from previous page

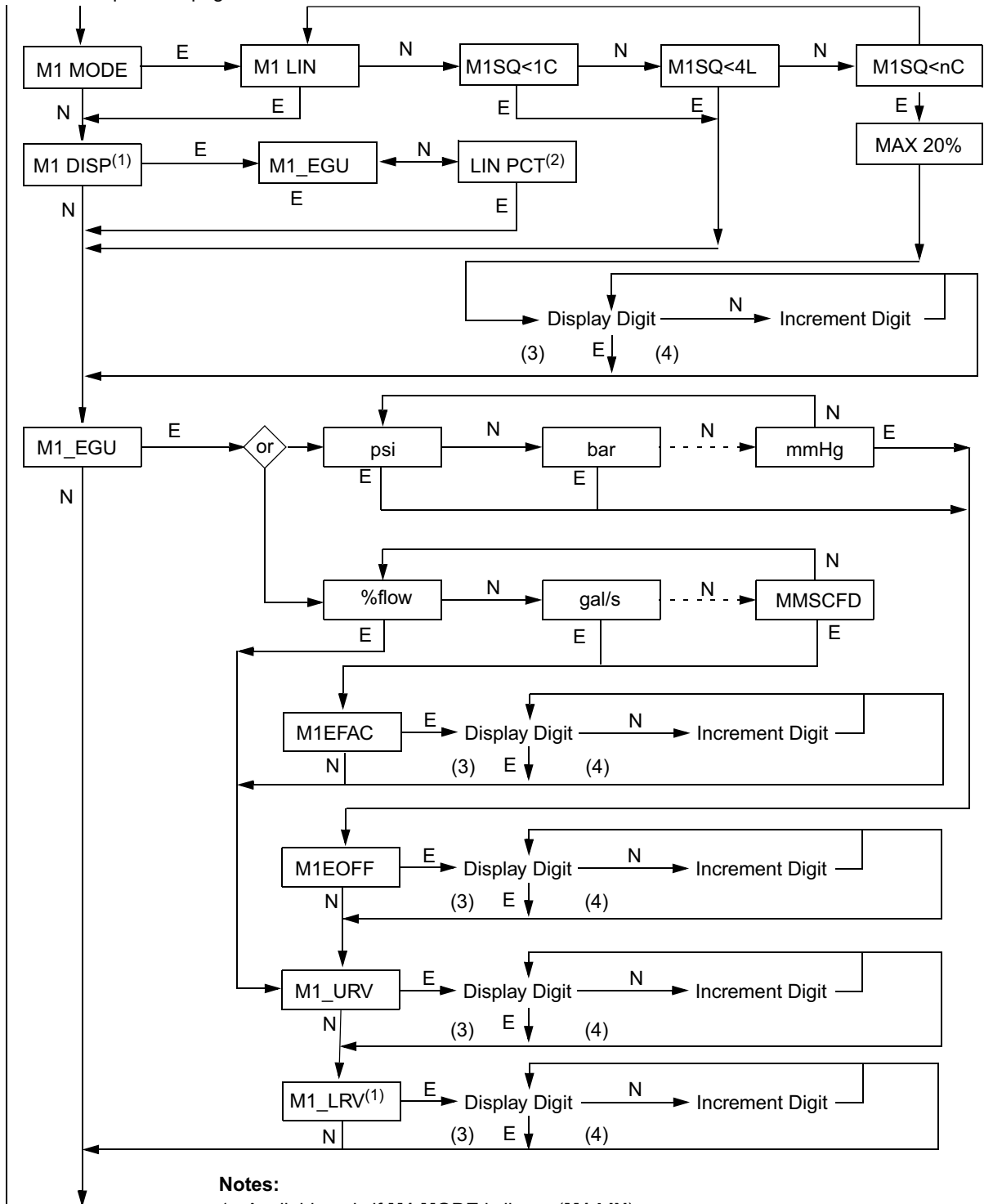

Notes:

1. Available only if **M1 MODE** is linear (**M1 LIN**).
2. **LIN PCT** provides percent output on local display only (linear mode).
Percent flow in square root is selectable under **M1_EGU**.
3. If character is the last position on the display line, advances to the next menu item.
4. If character is not the last position on the display line, advances to the next character.

Continued on next page

Figure 50 - Configuration Menu Structure, DP Transmitters (3 of 4)

Continued from previous page

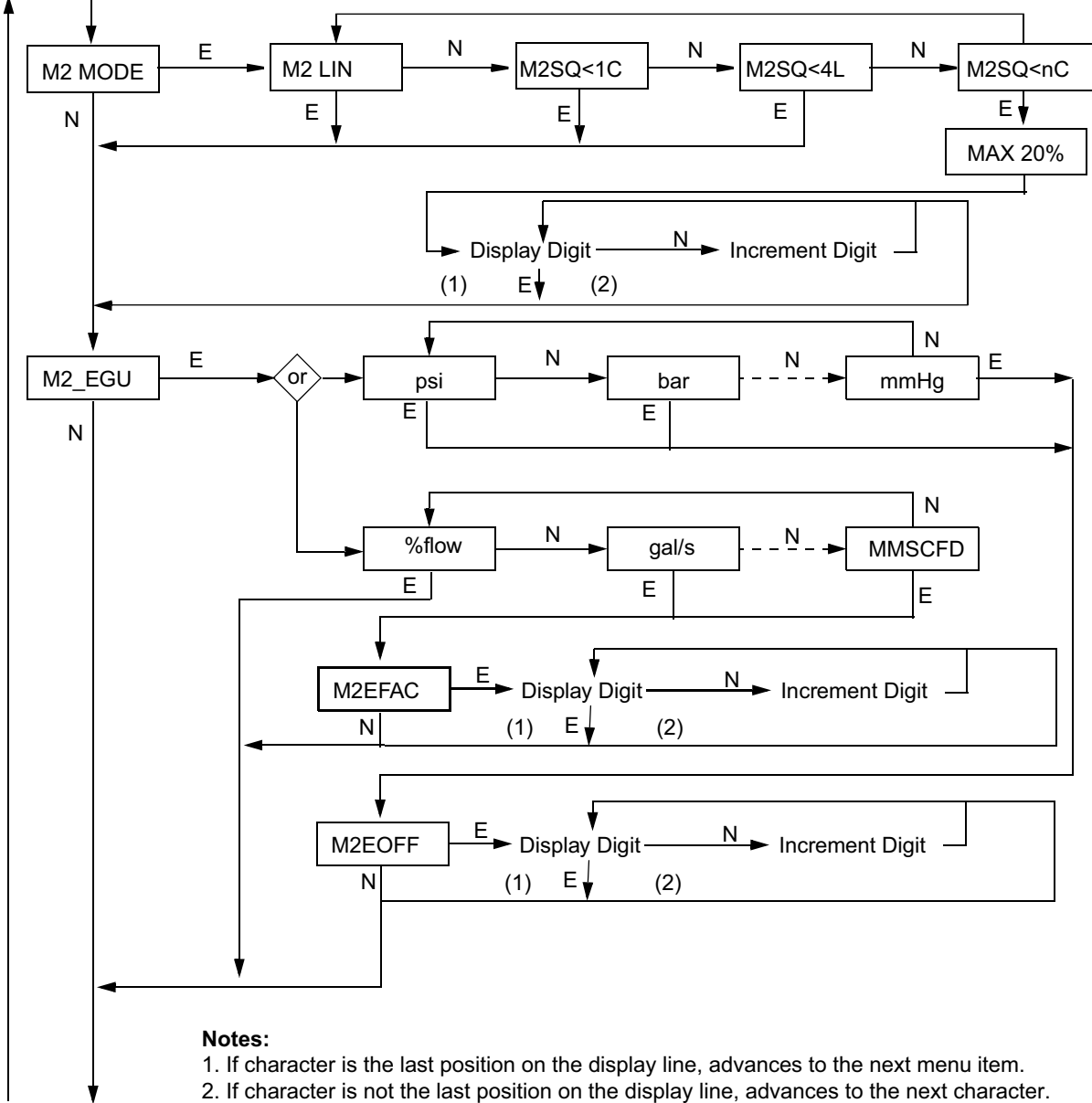

Continued on next page

Figure 51 - Configuration Menu Structure, DP Transmitters (4 of 4)

Continued from previous page

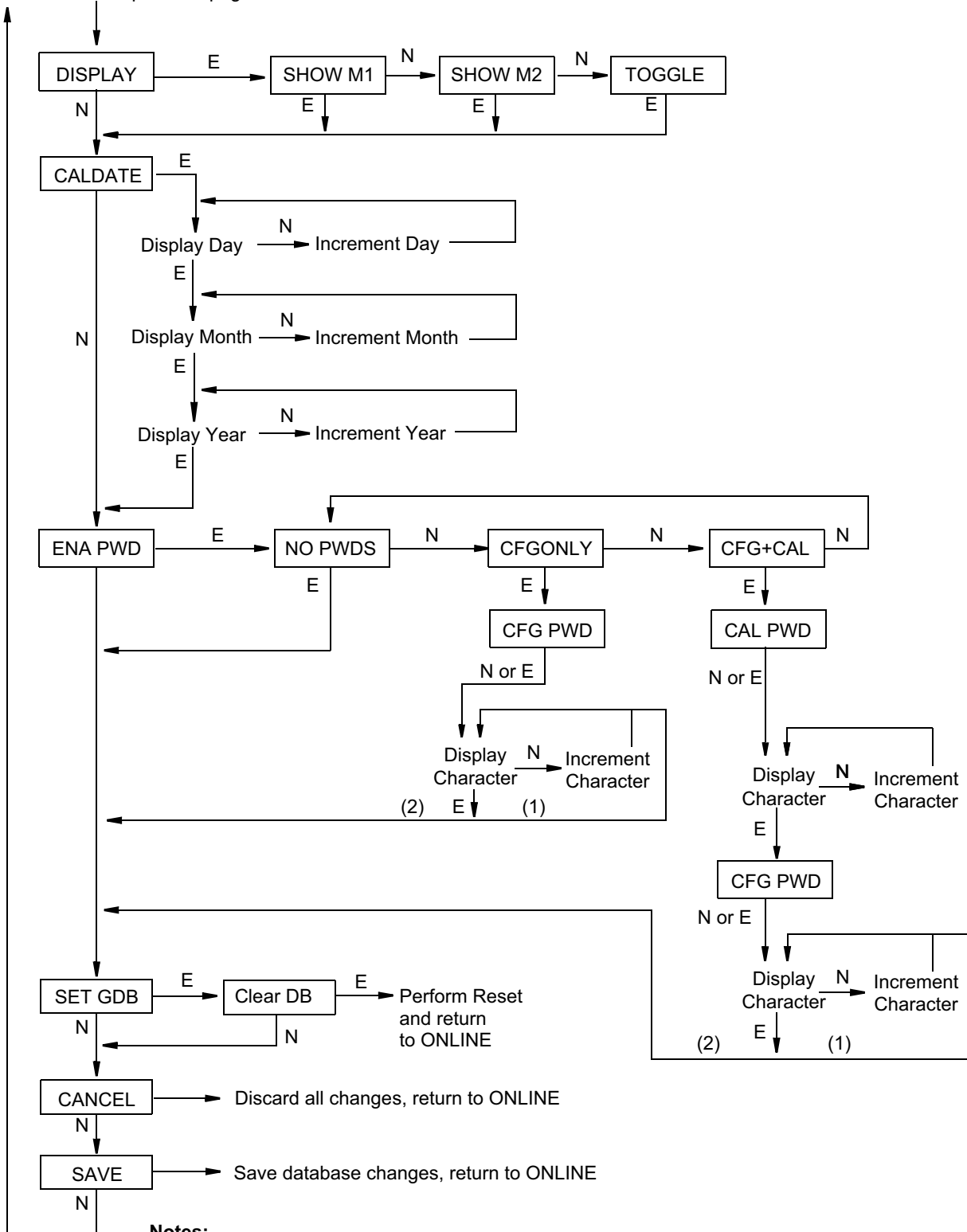

Notes:

1. If character is not the last position on the display line, advances to the next character.
2. If character is the last position on the display line, advances to the next menu item.

Configuration Menu Items

In general, use the **NEXT** button to select an item, and the **ENTER** button to specify a selection.

Item	Description	Default
POLLADR	The transmitter poll address can be set to a value of 0 through 63. To configure the transmitter poll address, press ENTER at the POLLADR prompt. Use the NEXT button to select an address between 0 and 63, then press ENTER .	0
LOOP MD	<p>mA Loop Current Mode can be set to Enabled (active 4 to 20 mA), or Disabled (fixed value of 4.0 mA).</p> <p>To configure mA Loop Mode, navigate to the LOOP MD menu selection and press ENTER. Use the NEXT button to select MA DIS to disable mA Loop Mode, or MA ENA to enable mA Loop Mode.</p> <p>By default, the LOOP MD parameter is set to enabled (MA ENA), which allows the transmitter to operate with a 4 to 20 mA output signal.</p> <p>To lock the transmitter's milliamp output at a fixed value of 4.0 mA, set LOOP MD to disabled (MA DIS). When loop mode is disabled, the AO ALM, OUT DIR, OFFL MA, and mA adjustment selections will not be available from the menu structure after you save the configuration.</p>	Enabled (Active 4 to 20 mA)
EX ZERO ⁴³	<p>The External Zero feature allows you to enable or disable the optional external zero pushbutton.</p> <p>Navigate to the EX ZERO menu selection and press ENTER. Use the NEXT button to select EXZ DIS (disable) or EXZ ENA (enable), and press ENTER.</p>	Disabled
S2 BAD	<p>The temperature sensor compensates for changes in temperature in the transmitter electronics. A bad sensor can cause a 4 to 20 mA accuracy change of up to 0.25%. The S2 BAD feature allows you to specify action (or no action) if such a condition occurs.</p> <p>To configure this feature, navigate to the S2 BAD menu selection and press ENTER. Use the NEXT button to select AO ALM if you want the output go to the value configured in AO ALM, or select USE DEF to continue operation with a potentially bad temperature sensor.</p> <p>This menu option is not available when the milliamp output is fixed at 4.0 mA (that is, when LOOP MD is set to MA DIS), and is bypassed if either M1 MODE or M2 MODE is configured as square root.</p>	USE DEF ⁴⁴
OUT DIR	<p>The 4 to 20 mA output direction can be set to forward or reverse.</p> <p>To configure the output direction, navigate to the OUT DIR menu selection and press ENTER. Use the NEXT button to select OUT FWD (4 to 20 mA) or OUT REV (20 to 4 mA), and press ENTER.</p> <p>This option is not available when the current output is fixed at 4.0 mA (that is, when LOOP MD is set to MA DIS).</p>	Forward
AO ALM	<p>The 4 to 20 mA alarm mode can be configured so that the transmitter's output will be set to either the high value or low value under specific conditions.</p> <p>Navigate to the AO ALM menu selection and press ENTER. Use the NEXT button to select LO ALM or HI ALM and press ENTER.</p> <p>This option is not available when the current output is fixed at 4.0 mA (that is, when LOOP MD is set to MA DIS).</p>	HI ALM
OFFL MA	<p>This parameter allows you to configure the 4 to 20 mA output in offline mode. OFFL MA can be configured so that the transmitter's output will be set to either the last output value or to a user-specified value if the transmitter goes offline.</p> <p>To configure the offline output, press ENTER at the prompt OFFL MA.</p> <ul style="list-style-type: none"> To use the last good output value, press NEXT to select LAST MA, then press ENTER. To specify a different value, navigate to USER MA by pressing NEXT, then press ENTER. Enter the desired value (see <i>Entering Strings and Numeric Values</i>, page 52), then press ENTER. The display advances to the next menu item. <p>This menu option is not available when the milliamp output is fixed at 4.0 mA (that is, when LOOP MD is set to MA DIS).</p>	USER MA

43. For transmitters that have the External Zero option.

44. Select **AO ALM** for additional SIL diagnostics.

Item	Description	Default
DAMPING	<p>Damping can be set to 0, 0.25, 0.5, 1, 2, 4, 8, 16, or 32 seconds.</p> <p>To configure damping, navigate to the DAMPING menu selection and press ENTER. Use the NEXT button to select the desired damping value, then press ENTER.</p> <p>NOTE: Selecting a value of DAMP0 provides the fastest response.</p>	DAMP1/4
M1 MODE	<p>For DP transmitters, the mode of the primary output can be set to linear or a type of square root.</p> <p>To configure the mode of the primary output, press ENTER at the prompt M1 MODE, then use the NEXT button to select one of the following:</p> <ul style="list-style-type: none"> • M1 LIN: Linear (pressure units) • M1SQ<1C: Square root flow calculation with cutoff below 1% of calibrated <i>pressure</i> range • M1SQ<4L: Square root flow calculation with linear extrapolation below 4% of calibrated <i>pressure</i> range • M1SQ<nC: Square root flow calculation with a user-configured cutoff specified between 0 and 20% of the <i>flow</i> upper range value, M1EFAC 	Linear
M1 DISP	<p>If the primary output is in linear mode, this parameter allows you to configure the display to show engineering units or percent of span. (If the primary output is a square root flow calculation, M1 DISP is not available.)</p> <p>To configure the display to show engineering units or percent, navigate to the M1 DISP menu selection and press ENTER. Use the NEXT button to select M1_EGU or LIN PCT and press ENTER.</p>	Engineering units
M1_EGU	<p>This parameter allows you to set the engineering units for the primary measurement.</p> <ul style="list-style-type: none"> • If M1 MODE is set to M1 LIN: <ol style="list-style-type: none"> 1. Select one of the following pressure engineering units for your display and transmission: inH₂O, ftH₂O, mmH₂O, inHg, mmHg, cmHg, mHg, psi, psf, mbar, bar, g/cm², kg/cm², kg/m², Pa, hPa, kPa, MPa, torr, inWC60, ftWC60, inWC4, ftWC4, mmWC4, cmWC4, mWC4, atm, dy/cm². 2. The transmitter then adjusts M1EFAC (engineering factor), M1_URV (upper range value), M1_LRV (lower range value), and defaults the M1EOFF parameter to zero. • For DP transmitters only, when M1 MODE is set to any of the square root settings (M1SQ<1C, M1SQ<4L, or M1SQ<nC): <ol style="list-style-type: none"> 1. Select one of the following flow engineering units for your display and transmission: gal/s, gal/m, gal/h, gal/d, Mgal/d, ft³/s, ft³/m, ft³/h, ft³/d, lgal/s, lgal/m, lgal/h, lgal/d, l/s, l/m, l/h, l/d, m³/s, m³/m, m³/h, m³/d, NI/h, Nm³/h, Sm³/h, Am³/h, Sft³/m, MSCFD, MMSCFD, bbl/s, bbl/m, bbl/h, bbl/d, g/s, g/m, g/h, kg/s, kg/m, kg/h, kg/d, lb/s, lb/m, lb/h, lb/d, t/m, t/h, t/d, STon/m, STon/h, STon/d, LTon/h, LTon/d, %flow. 2. Check the M1EFAC (M1 engineering factor) and adjust it if necessary. 	inH ₂ O or psi
M1EOFF	<p>This parameter allows you to configure an offset value to apply to the primary measurement.</p> <p>You can introduce an offset by entering a nonzero value for M1EOFF. The offset affects the value of the PV that is transmitted in engineering units, transmitted as an analog mA signal, and shown on the display.</p> <p>This feature can be used in applications such as an elevated water storage tank where the transmitter is at grade level but the output corresponds to the level of the tank. An offset value can also be used for a grade level water storage tank where the transmitter is installed above the bottom of the tank where the output should correspond to the level in the tank.</p>	0
M1EFAC	<p>For DP transmitters, the M1EFAC parameter is the numerical relationship between the measured span in pressure units vs. the displayed (and transmitted) span in flow units. It is the displayed URV in flow units (which is also the span in flow units, since flow ranges must be zero-based).</p> <p>For example, for a 200 inH₂O transmitter with a measured range of 0 to 100 inH₂O and displayed range of 0 to 500 gal/m, set M1EFAC to 500.</p> <p>NOTE: Actual flow rates in the process are dependent upon your specific installation (pipe diameter, for example). Be sure to use values for M1EFAC and M2EFAC that correspond to your installation and process conditions.</p> <p>To edit the span in your configured flow units, navigate to the M1EFAC menu selection and press ENTER. (See <i>Entering Strings and Numeric Values</i>, page 52.)</p>	n/a

Item	Description	Default
M1_URV	<p>This parameter allows you to configure the upper range value of the primary measurement.</p> <p>To edit the upper range value of the primary measurement, navigate to the M1_URV menu selection and press ENTER. Define your URV. (See <i>Entering Strings and Numeric Values</i>, page 52.)</p>	URL
M1_LRV	<p>This parameter allows you to configure the lower range value of the primary measurement.</p> <p>To edit the lower range value of the primary measurement, navigate to the M1_LRV menu selection and press ENTER. Define your LRV. (See <i>Entering Strings and Numeric Values</i>, page 52.)</p>	0
M2 MODE	<p>M2 is a secondary measurement that is read by the HART communicator can be shown on the display. You might use this feature to display M1 in your primary pressure units, and M2 in a different set of pressure units.</p> <p>For AP and GP transmitters, the secondary output is in linear mode, which corresponds to pressure units. For DP transmitters, M2 can also be configured to a square root mode, which corresponds to flow units. To configure the mode of the secondary output, press ENTER at the M2 MODE prompt, and then use the NEXT button to select one of the following:</p> <ul style="list-style-type: none"> • M2 LIN: Linear (pressure units) • M2SQ<1C: Square root flow calculation with cutoff below 1% of calibrated differential pressure range • M2SQ<4L: Square root flow calculation with linear extrapolation below 4% of calibrated differential pressure range • M2SQ<nC: Square root flow calculation with a user-configured cutoff specified between 0 and 20% of the flow upper range value, M2EFAC 	Linear
M2_EGU	<p>This parameter allows you to set the engineering units for the secondary measurement.</p> <ul style="list-style-type: none"> • When M2 MODE is set to M2 LIN: <ol style="list-style-type: none"> 1. Select one of the following pressure engineering units for your display and transmission: inH₂O, ftH₂O, mmH₂O, inHg, mmHg, cmHg, mHg, psi, psf, mbar, bar, g/cm², kg/cm², kg/m², Pa, hPa, kPa, MPa, torr, inWC60, ftWC60, inWC4, ftWC4, mmWC4, cmWC4, mWC4, atm, dy/cm². 2. The transmitter then automatically adjusts M2EFAC (engineering factor), M2_URV (upper range value), M2_LRV (lower range value), and defaults the M2EOFF parameter to zero. • For DP transmitters only, when M2 MODE is set to any of the square root settings (M2SQ<1C, M2SQ<4L, or M2SQ<nC): <ol style="list-style-type: none"> 1. Select one of the following flow engineering units for your display and transmission: gal/s, gal/m, gal/h, gal/d, Mgal/d, ft³/s, ft³/m, ft³/h, ft³/d, lgal/s, lgal/m, lgal/h, lgal/d, l/s, l/m, l/h, Ml/d, m³/s, m³/m, m³/h, m³/d, Nl/h, Nm³/h, Sm³/h, Am³/h, Sft³/m, MSCFD, MMSCFD, bbl/s, bbl/m, bbl/h, bbl/d, g/s, g/m, g/h, kg/s, kg/m, kg/h, kg/d, lb/s, lb/m, lb/h, lb/d, t/m, t/h, t/d, STon/m, STon/h, STon/d, LTon/h, LTon/d, %flow. 2. Check the M2EFAC (M2 engineering factor) and adjust it if necessary. 	Same as M1_EGU
M2EFAC	<p>For DP transmitters, the M2EFAC parameter is the numerical relationship between the measured span in pressure units and the displayed (and transmitted) span in flow units. It is the displayed URV in flow units (which is also the span in flow units, since flow ranges must be zero-based).</p> <p>For example, for a 200 inH₂O transmitter with a measured range of 0 to 100 inH₂O and displayed range of 0 to 500 gal/m, set M2EFAC to 500.</p> <p>NOTE: Actual flow rates in the process are dependent upon your specific installation (pipe diameter, for example). Be sure to use values for M1EFAC and M2EFAC that correspond to your installation and process conditions.</p> <p>To edit the span in your configured flow units, navigate to the M2EFAC menu selection and press ENTER. (See <i>Entering Strings and Numeric Values</i>, page 52.)</p>	n/a
M2EOFF	<p>This parameter allows you to configure an offset value to apply to the secondary measurement.</p> <p>You can introduce an offset by entering a nonzero value for M2EOFF. The offset affects the value of the PV that is transmitted in engineering units, transmitted as an analog mA signal, and displayed.</p> <p>This feature can be used in applications such as an elevated water storage tank where the transmitter is at grade level but the output corresponds to the level of the tank. An offset value can also be used for a grade level water storage tank where the transmitter is installed above the bottom of the tank where the output should correspond to the level in the tank.</p>	0

Item	Description	Default
DISPLAY	<p>This parameter allows you to configure whether the display shows M1, M2, or toggles between M1 and M2.</p> <p>To configure the display value, navigate to the DISPLAY menu selection and press ENTER. Use the NEXT button to select SHOW M1, SHOW M2, or TOGGLE and press ENTER.</p>	M1
CALDATE	<p>CALDATE allows you to set the date of the last calibration. This parameter is optional, but it can be used for record-keeping or plant maintenance.</p> <p>To edit the calibration date, navigate to the CALDATE menu selection and press ENTER. You can then change the day, month, and year. The display shows the last date with the day flashing. Use the NEXT button to step through the library of digits to select the desired day, then press ENTER. Repeat this process for the month and year.</p>	None, or date of calibration in factory
ENA PWD	<p>This parameter allows you to enable or disable password(s). By default, passwords are disabled.</p> <p>NOTE: CAL PWD allows access to calibration mode only; CFG PWD allows access to both configuration and calibration.</p> <p>To set a password for configuration only, or for both configuration and calibration:</p> <ol style="list-style-type: none"> 1. Navigate to ENA PWD and press ENTER. 2. Navigate to CFGONLY or CFG+CAL and press ENTER. <ul style="list-style-type: none"> • If you selected CFG+CAL, the CAL PWD prompt appears. • If you selected CFGONLY, the CFG PWD prompt appears. 3. Use the NEXT button to step through the library of characters to select the desired first character, then press ENTER. Your selection is entered, and the second character flashes. Repeat this procedure until you have created your password. <ul style="list-style-type: none"> • If the password has fewer than six characters, use blanks for the remaining positions. 4. When you have configured the sixth position, the display advances to the next menu item. 5. Record your new password before saving changes to the database. <p>To disable passwords:</p> <ol style="list-style-type: none"> 1. Navigate to the ENA PWD menu selection and press ENTER. 2. Navigate to the NO PWDS menu selection and press ENTER. <ul style="list-style-type: none"> • If a configuration password was previously set, you are prompted to enter it. 	NO PWD
CFG PWD	User-set configuration password (six characters).	None
CAL PWD	User-set calibration password (six characters).	None
SET GDB	<p>SET GDB allows you to rewrite calibration values (slope and offset) with default values. It resets M1 and M2 EGUs to psi.</p> <p>If your transmitter database becomes corrupted and you receive an INITBAD message upon startup, this function enables you to rewrite the calibration values with default values.</p> <p>NOTE: Any user calibration values you have entered will be lost. Therefore, do not select SET GDB if your transmitter is functioning normally.</p>	n/a

Messages

The following configuration-related messages may appear on the optional display.

Parameter	Condition Tested	Message	Description
Password Protection	Password	BAD PWD	Bad password entered; use another.
Write Protection	Write Protection Enabled	REJECT	User attempted an action that is write-protected.
M1 MODE ⁴⁵	M1_LRV≠0	LRVnot0	Square root mode with nonzero LRV is not valid. Change M1_LRV to 0.
	M1_URV<0	URV<LRV	Square root mode with negative URV is not valid. Change M1_URV to a positive value.
	OUT DIR is OUT REV	URV<LRV	Square root mode with URV less than LRV is not valid. Change M1_LRV to 0 and M1_URV to a positive value.
	M1EFAC<0 or M2EFAC<0	-M1EFAC -M2EFAC	M1EFAC and M2EFAC cannot be negative. Change to a positive value.
	M1EFAC=0 or M2EFAC=0	0M1EFAC 0M2EFAC	M1EFAC and M2EFAC cannot be zero. Change to a positive value.
	M1EOFF≠0 or M2EOFF≠0	BADEOFF	Square root mode with nonzero M1EOFF and M2EOFF is not valid. Change M1EOFF and M2EOFF to 0.
M1EFAC ⁴⁵	M1EFAC<0	-M1EFAC	Negative M1EFAC is not valid. Change M1EFAC to a positive value.
	M1EFAC=0	0M1EFAC	M1EFAC=0 is not valid. Change M1EFAC to a positive value.
M1_URV	M1_URV>max pressure in EGU	URV>FMX	Entered pressure is greater than maximum rated pressure of transmitter. Check entry. Verify EGUs.
	M1_URV<min pressure in EGU	URV<FMN	Entered pressure is less than the minimum rated pressure of the transmitter. Check entry. Verify EGUs.
	M1_URV=M1_LRV	LRV=URV	Cannot set span to 0. Check entry. Check M1_LRV .
	M1 turndown exceeds limit	BADTDWN	Check entry. Check M1_LRV .
	URV<0 with M1 or M2 SqRt	URV<LRV⁴⁵	Square root mode with nonzero LRV is not valid. Change M1_LRV to 0.
M1_LRV	M1_LRV>max pressure in EGU	LRV>FMX	Entered pressure is greater than the maximum rated pressure of the transmitter. Check entry. Verify EGUs.
	M1_LRV<min pressure in EGU	LRV<FMN	Entered pressure is less than the minimum rated pressure of the transmitter. Check entry. Verify EGUs.
	M1_URV=M1_LRV	LRV=URV	Cannot set span to 0. Check entry. Check M1_URV .
	M1 turndown exceeds limit	BADTDWN	Check entry. Check M1_URV .

45. DP transmitters only.

Parameter	Condition Tested	Message	Description
M2 MODE ⁴⁶ (being changed to square root)	M1_LRV≠0	LRVnot0	Square root mode with nonzero LRV is not valid. Change M1_LRV to 0.
	M1_URV<0	URV<LRV	Square root mode with negative URV is not valid. Change M1_URV to a positive value.
	OUT DIR is OUT REV	URV<LRV	Square root mode with URV less than LRV is not valid. Change M1_LRV to 0 and M1_URV to a positive value.
	M1EFAC<0 or M2EFAC<0	-M1EFAC -M2EFAC	M1EFAC and M2EFAC cannot be negative. Change to a positive value.
	M1EFAC=0 or M2EFAC=0	0M1EFAC 0M2EFAC	M1EFAC and M2EFAC cannot be zero. Change to a positive value.
	M1EOFF≠0 or M2EOFF≠0	BADEOFF	Square root mode with nonzero M1EOFF and M2EOFF is not valid. Change M1EOFF and M2EOFF to 0.
M2EFAC ⁴⁶	M2EFAC<0	-M2EFAC	Negative M2EFAC is not valid. Change M2EFAC to a positive value.
	M2EFAC=0	0M2EFAC	M2EFAC =0 is not valid. Change M2EFAC to a positive value.

Configuration Using a PC50

To configure the transmitter using a PC50 Configurator, follow the procedures in MI 020-501 and MI 020-520.

Configuration Using a HART Communicator

To configure the transmitter using a HART communicator, follow the procedures in *Using the HART Communicator*, page 89.

⁴⁶. DP transmitters only.

Calibration

You can calibrate the transmitter by accessing the menu system using the **ENTER** and **NEXT** buttons on the optional local display, by using the optional external zero button, or by using a remote configurator.

FoxCal™ Multiple Calibration Technology

% Reading Accuracy

Transmitters in the Advanced (10S) and Premium (50S) performance tiers offer FoxCal™ technology, a patented multiple calibration feature that helps eliminate the need for a traditional single-span calibration at an application-specific pressure range. Transmitters with the FoxCal™ feature enabled use multiple calibrated ranges that are stored in on-board memory. The calibrated ranges are preset in the factory and cover the full pressure range of the transmitter. During operation, a real-time, seamless transition from one factory-calibrated range to another maintains digital accuracy as a percent of reading from 100% to as low as 4% of the upper range limit (URL).

% Rerange Span Accuracy

The FoxCal™ feature also supports rerange accuracy. Factory calibration and field calibration for specific applications are not required for zero-based ranges up to 30:1 turndown. Simply configure or rerange the URV without performing a recalibration at the URV. You will only need to perform a zero adjustment after installation to obtain performance to the specified reference accuracy.

Refer to *Span and Range Limits*, page 12.

Enabling and Disabling FoxCal™

The transmitter can be shipped with or without the FoxCal™ feature enabled. If you select the -C1 option in the model code, FoxCal™ is not enabled, and the transmitter is factory calibrated over the specified range. If you do not select the -C1 option in the model code, FoxCal™ is enabled.

The FoxCal™ calibration feature can be enabled or disabled by selecting **FOXCAL** from the **CALIB** menu on the LCD and selecting **FCALON** or **FCALOFF**.

When FoxCal™ is disabled, the last two-point calibration is enabled. As shipped, the last two-point calibration defaults to a calibration from 0 to URL; or, for transmitters ordered with the -C1 option, the two-point Custom Factory Calibration range. If a two-point field calibration is performed later, the last calibration becomes the last field calibration.

If you perform a two-point calibration on a transmitter with FoxCal™ enabled, the new calibration is used, and FoxCal™ is disabled. Re-enable FoxCal™ by selecting **FOXCAL** from the **CALIB** menu and selecting **FCALON**.

NOTICE

POTENTIAL REDUCED PERFORMANCE

When disabling FoxCal™, the last two-point calibrated range may not match the current configuration of the Lower Range Value and Upper Range Value. For optimal performance, avoid large mismatches.

Failure to follow these instructions can result in reduced performance.

One-Point Calibration at LRV

A one-point offset calibration at LRV can be performed with either FoxCal™ or the last two-point calibration enabled.

When a one-point calibration at LRV is performed, the offset adjustment applies to both the last two-point calibration and all the multiple calibrations. The calibrated accuracy at the LRV point is adjusted and maintained for both calibrations, regardless of which selection is enabled at the time of the adjustment. This allows you to enable or disable FoxCal™ without also performing two independent offset adjustments.

Two-Point Field Calibration

The transmitters, including those shipped with the FoxCal™ feature enabled, can be recalibrated to a specific LRV and URV.

NOTE: The calibration at the LRV point applies to transmitters with the FoxCal™ feature enabled as well as transmitters calibrated with a two-point calibration. However, the calibration at the URV point applies only to the two-point calibration. Multiple calibrations stored in the transmitter in the factory do not change when a URV calibration is performed. Instead, as with a custom factory calibration, a field calibration at URV automatically disables the FoxCal™ feature and enables a single two-point calibration.

NOTICE

POTENTIAL REDUCED PERFORMANCE

The accuracy of the input pressure for field span calibration should be a minimum of four times better than the transmitter's reference accuracy specification. An inaccurate span pressure input typically results in degradation of transmitter performance from the factory calibrated state.

Failure to follow these instructions can result in reduced performance.

Calibration Notes

- If you perform a two-point calibration when the FoxCal™ feature is enabled, the new calibration is used and FoxCal™ is disabled.
- For best results in applications where high accuracy is required, rezero the transmitter output once it has stabilized at the final operating temperature.
- Zero shifts resulting from position effects can be eliminated by rezeroing the transmitter output.
- After calibrating, check the underrange and overrange output values to ensure that they extend beyond 4 and 20 mA, respectively.
- (DP transmitters only) When checking the zero reading of a transmitter operating in the square root mode, return the output to the linear mode. This eliminates an apparent instability in the output signal. Return the transmitter output to the square root mode after the zero check is complete.
- The internal digital value of pressure can be shown on the optional local display, converted to a 4 to 20 mA analog output signal, and transmitted digitally.
- The transmitter database has configurable values for both lower range value (LRV) and upper range value (URV). You can display the LRV and URV in pressure units by selecting the **RE RANGE** function on the LCD. These values are used for two functions:
 - Defining the calibrated range when using the pushbuttons for calibration:

- When either **CAL LRV** or **CAL URV** is initiated from the pushbuttons, the transmitter expects that the pressure applied at the time the button is pressed is equal to the LRV or URV value, respectively.
 - This function trims the internal digital value of pressure; that is, it performs a calibration based on the application of accurate pressures equal to the values entered for LRV and URV in the transmitter database.
 - This function also sets the 4 and 20 mA output points; that is, the 4 and 20 mA points that correspond to the values of LRV and URV in the database.
 - The value of LRV can be larger than the value of URV.
 - Reranging without the application of pressure:
 - Since the transmitter continually determines an internal digital value of the measured pressure from the lower range limit (LRL) to the upper range limit (URL), the 4 and 20 mA output points can be assigned to any pressure values within the span and range limits without application of pressure.
 - The reranging function is accomplished by entering new database values for LRV and URV.
 - Reranging does not affect the calibration of the transmitter; that is, it does not affect the optimization of the internal digital value of pressure over the calibrated range.
 - If FoxCal™ is disabled and the reranged LRV and URV are not within the calibrated range, the measured values may not be as accurate as when they are within the calibrated range.
 - (DP transmitters only) If the transmitter is in square root mode for flow rate measurement, the URV in the database is displayed as the flow rate URV when the view database (**VIEW DB**) function is used. However, the LRV and URV in pressure units can be displayed by selecting the **RERANGE** function. LRV is always zero when the transmitter is configured for square root mode.
 - When the local display is used, the internal digital value of pressure is sent directly to the display.
 - The display can show any measured pressure in selected units regardless of the calibrated range and the values of LRV and URV (within the limits of the transmitter and display).
 - If the measured pressure is outside the range established by the LRV and URV values in the database, the display shows the measurement but also continually blinks to indicate that the measurement is out of range. The signal is saturated at either the low or high overrange limit, respectively, but the display continually shows the pressure.
 - The internal digital value of pressure is converted to an analog signal.
 - The transmitter sets the output at 4 mA for the LRV and 20 mA for the URV.
 - There is an independent trim on the digital-to-analog conversion stage. This trim allows for slight adjustment of the 4 and 20 mA outputs. This compensates for any small difference between the transmitter output and an external reference device which is measuring the current.
 - The trim does not affect the calibration or the reranging of the transmitter and does not affect the internal digital value of pressure or the transmission or display of measured pressure.
 - The trim can be done with or without pressure applied to the transmitter.
 - Zeroing from the local display does not affect the span.
- When the transmitter is zeroed to compensate for installed position effect, the transmitter can have either LRV pressure applied (**CAL LRV**) or zero pressure applied (**CAL AT0**). If the range is zero-based, either method produces the same result. However, if the range is not zero-based, it is advantageous to have both methods available.

For example, consider a pressure transmitter having a range of 50 to 100 psig. If it is not feasible to vent the transmitter to atmosphere (or bypass the high and low sides) for zeroing, it can be adjusted while the LRV pressure of 50 psi is applied by using the **CAL LRV** function on the LCD.

On the other hand, if the transmitter has been installed but there is no pressure in the process line yet (or if the high and low sides can be connected by a bypass valve), it can be zeroed while open to atmosphere by using the **CAL AT0** function on the LCD.

- Zeroing with LRV pressure applied (**CAL LRV**):
 - Before using this zeroing function, apply a pressure to the transmitter equal to the value of LRV stored in the transmitter database.
 - When you zero the transmitter, the internal digital value of the pressure is trimmed to be equal to the value of LRV stored in the database, and the output set to 4 mA.
 - If zeroing is done when the applied pressure is different from the LRV pressure value in the database, the internal digital value of pressure is biased by the difference in the values, but the output is still set at 4 mA.
 - Use the **CAL LRV** and **CAL URV** functions when calibrating a transmitter for a specific range with known input pressures applied for the LRV and URV. FoxCal™ is automatically disabled by the **CAL URV** function.
- Zeroing a gauge or differential pressure transmitter with zero pressure applied (**CAL AT0**)⁴⁷:
 - Make sure that the applied pressure is at zero. This means venting the transmitter to atmosphere, or opening a bypass valve to connect the high and low sides.
 - When you zero the transmitter, the internal digital value of the pressure is trimmed to be equal to zero, and the current output is set to an appropriate value such that the output is a nominal 4 mA when the LRV pressure is applied later.
- Zeroing an absolute pressure transmitter: Temporarily set the LRV to the barometric pressure, and perform a **CAL LRV** function with the transmitter vented to atmosphere. Then, set the LRV back to the proper value.

Calibration Setup

The following sections show setups for field and bench calibration. Use test equipment that is at least four times as accurate as the specified accuracy of the transmitter; otherwise, measurement inaccuracy may be introduced.

NOTICE

POTENTIAL REDUCED PERFORMANCE

For both field calibration and bench calibration procedures, using a pressure source that is less accurate than the transmitter's reference accuracy specification typically results in degradation of transmitter performance from the factory calibrated state. The accuracy of the input pressure should be a minimum of four times better than the transmitter's reference accuracy specification.

Failure to follow these instructions can result in reduced performance.

NOTE: Calibration is not necessary to rerange the transmitter to a different range. You can accurately rerange the transmitter by changing the lower and upper range values, which are stored in the transmitter database.

47. The **CAL AT0** function is not applicable with an absolute pressure transmitter. If an absolute pressure transmitter is vented to atmosphere, it does not have zero pressure applied. Instead, it has barometric pressure applied (approximately 14.7 psia at sea level).

Electronic Calibration Equipment

Figure 52 - Setup of Electronic Calibration Equipment

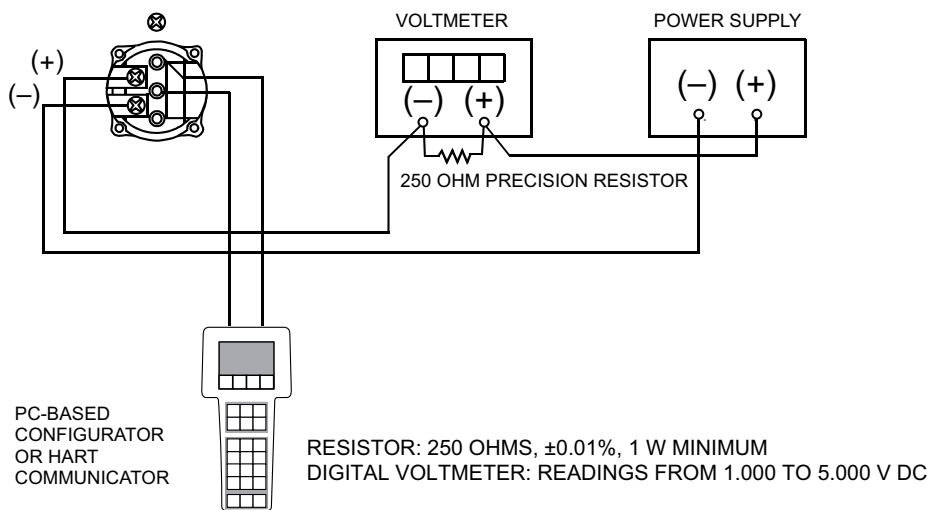

Field Calibration Setup

Field calibration is performed without disconnecting the process piping. If the transmitter is to be removed from the process for calibration, see *Bench Calibration Setup*, page 80.

An adjustable air supply and a pressure measuring device are required. For example, a dead weight tester or an adjustable clean air supply and pressure gauge can be used.

Field Calibration — Direct Connect AP and GP Transmitters

Field calibration is possible only if the transmitter is piped as shown in the diagram.

If you are calibrating the output signal, also connect equipment as shown in *Electronic Calibration Equipment*, page 78.

Figure 53 - Field Calibration Setup for Direct Connect Transmitters

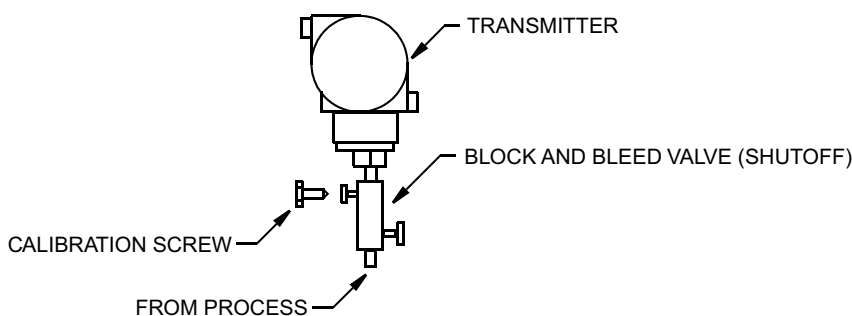

Block and Bleed Valve Maximum Pressure:

- 40 MPa (6000 psi) at 38°C (100°F)
- 25 MPa (4000 psi) at 250°C (400°F)

Calibration Screw Maximum Pressure:

- 0.7 MPa (100 psi) with Poly-Flo Fitting (F0101ES)

Field Calibration — Biplanar AP and GP Transmitters

Field calibration is possible only if you have a shutoff valve between the process and the transmitter, and the process covers vent screw option (-V1).

The pressure source can be connected to the transmitter with pipe fittings, or it can be connected to the vent screw assembly using a calibration screw. The calibration screw has a PolyFlo fitting and can be used for pressures up to 700 kPa (100 psi). It is available as Part Number F0101ES.

To set up the equipment, refer to the diagram and the following procedure:

Figure 54 - Field Calibration Setup for Biplanar Transmitters

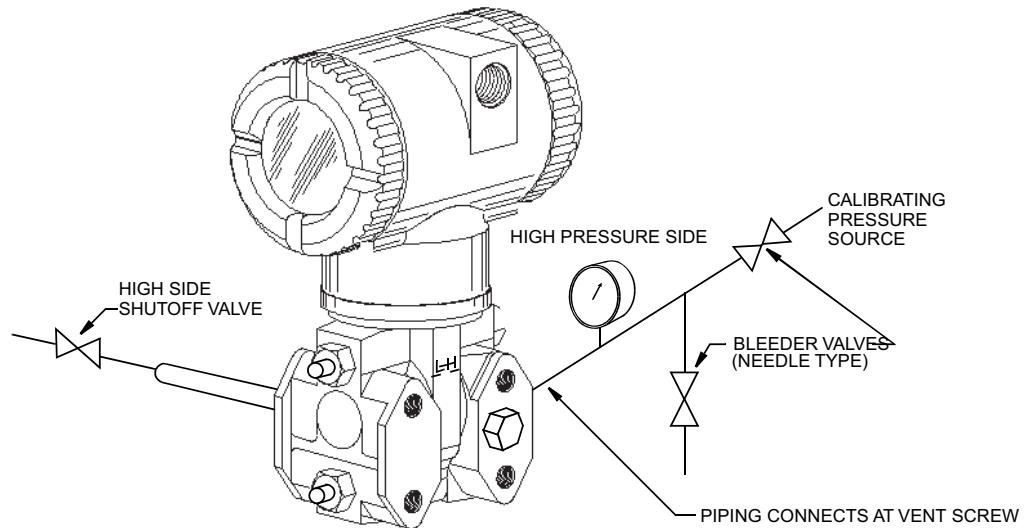

1. Close the shutoff valve between the process and the transmitter.
2. Take the appropriate step:
 - a. If a calibration screw **is** being used, remove the vent screw and replace it with the calibration screw. Connect the pressure source to the calibration screw using 6 x 1 mm or 0.250 inch tubing.
 - b. If a calibration screw is **not** being used, remove the drain plug or the entire vent screw assembly (as applicable) from the high pressure side of the transmitter. Connect calibration tubing using a suitable thread sealant.
3. If you are calibrating the output signal, also connect equipment as shown in *Electronic Calibration Equipment*, page 78..

Field Calibration — DP Transmitters

Field calibration is possible only if you have a bypass and shutoff valves between the process and the transmitter, and one of the following:

- Access to the process connections on the nonprocess side of the transmitter
- The optional vent screw in the side of the process covers

The pressure source can be connected to the transmitter with pipe fittings, or it can be connected to the vent screw assembly using a calibration screw. The calibration screw has a PolyFlo fitting and can be used for pressures up to 700 kPa (100 psi). It is available as Part Number F0101ES.

To set up the equipment, refer to the diagram and the following procedure:

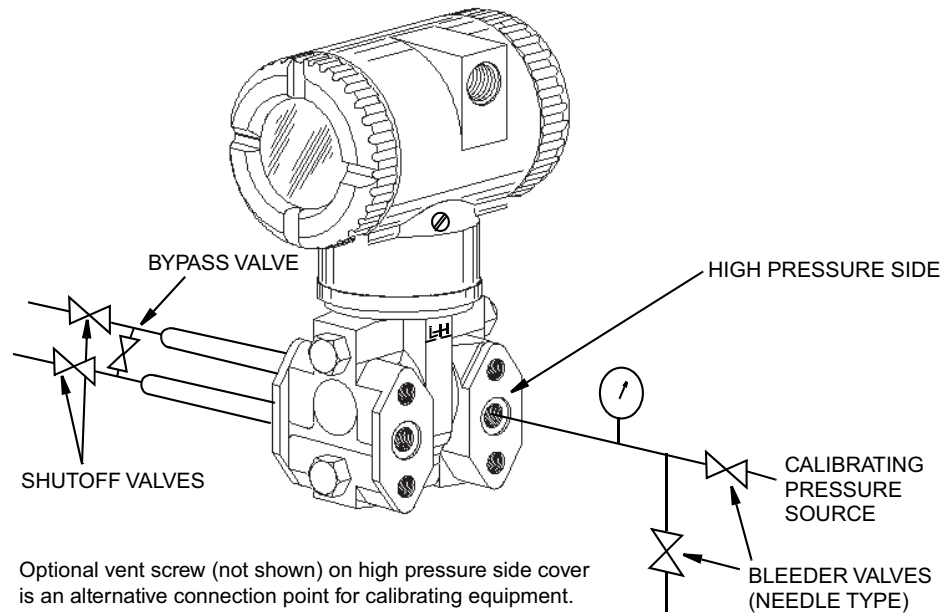
Figure 55 - Field Calibration Setup for DP Transmitters

1. If the transmitter is in operation, follow the steps described in *Taking a Differential Pressure Transmitter out of Operation*, page 49.

NOTICE

POTENTIAL REDUCED PERFORMANCE

With liquid service, drain both sides of the transmitter to avoid calibration errors.

Failure to follow these instructions can result in reduced performance.

2. Take the appropriate step:
 - a. If a calibration screw **is** being used, remove the vent screw and replace it with the calibration screw. Connect the pressure source to the calibration screw using 6 x 1 mm or 0.250 inch tubing.
 - b. If a calibration screw is **not** being used, remove the drain plug or the entire vent screw assembly (as applicable) from the high pressure side of the transmitter. Connect calibration tubing using a suitable thread sealant.
3. Close the bypass valve that was opened in Step 1.
4. Complete the setup shown in the diagram.

NOTE: For vacuum applications, connect the calibrating pressure source to the low pressure side of the transmitter.
5. If you are calibrating the output signal, also connect equipment as shown in *Electronic Calibration Equipment*, page 78.

Bench Calibration Setup

Bench calibration requires disconnecting the process piping. For calibration without disconnecting the process piping, see *Field Calibration Setup*, page 78.

For DP transmitters and biplanar AP and GP transmitters, connect the input piping to the high pressure side of the transmitter. Vent the low pressure side of the transmitter.

NOTE: For vacuum applications, connect the calibrating pressure source to the low pressure side of the transmitter.

See the following diagrams for the correct setup for each transmitter type. If you are calibrating the output signal, also connect equipment as shown in *Electronic Calibration Equipment*, page 78.

Figure 56 - Bench Calibration — Direct Connect AP and GP Transmitters

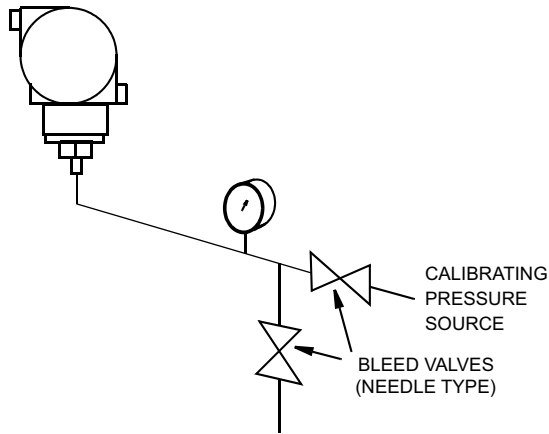

Figure 57 - Bench Calibration — Biplanar AP and GP Transmitters

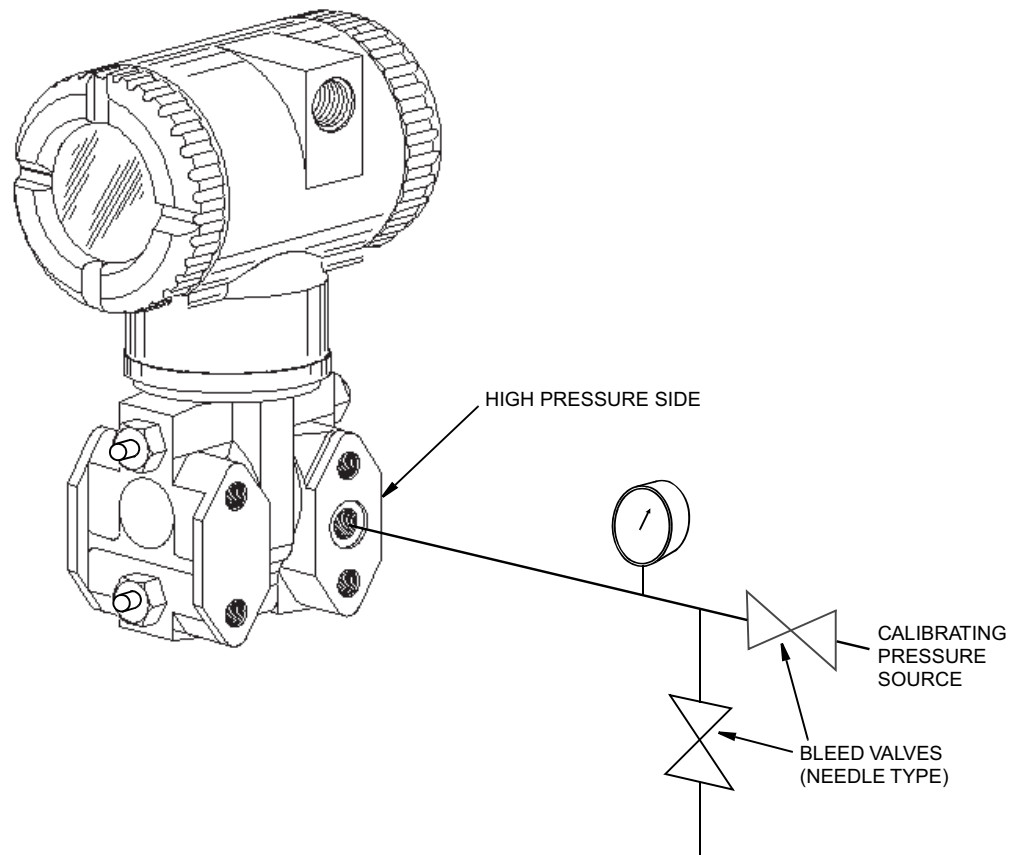
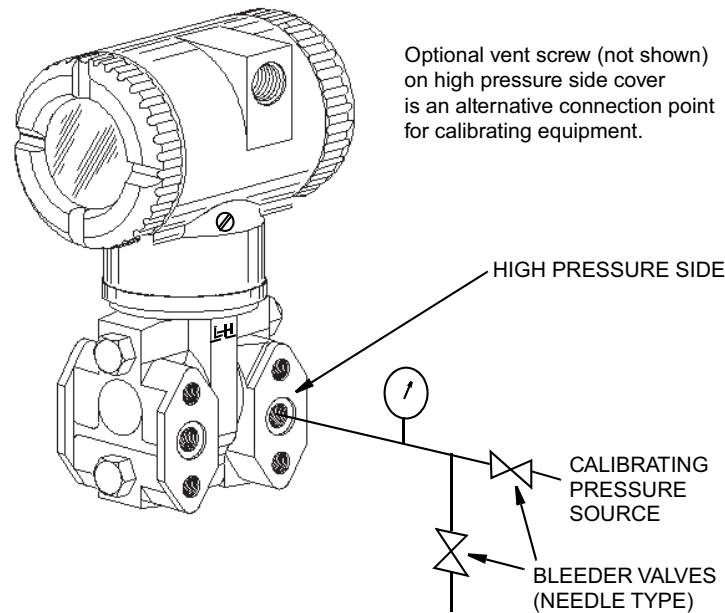

Figure 58 - Bench Calibration — DP Transmitters

Calibration Using the Optional Local Display

From the display, you can:

- Zero the transmitter at zero pressure
- Calibrate the lower range value (LRV or 0% range value)
- Calibrate the upper range value (URV or 100% range value)
- Rerange your transmitter by adjusting the 0% and 100% range values

To access calibration mode from normal operating mode, press the **NEXT** button repeatedly until the display reads **CALIB**. Press the **ENTER** button to select **CALIB**. The display shows the first item in the Calibration menu.

NOTE:

- During calibration, a single change could affect several parameters. For this reason, if you make a mistake, review the entire database. Or, use the **CANCEL** feature to restore the transmitter to its starting configuration and begin again.
- During adjustment of 4 and 20 mA in the Calibration menu, the mA output does not reflect live measurement values.
- If your transmitter is write protected, you cannot write your calibration to the electronics without disabling write protection.

Proceed to calibrate your transmitter by using the **NEXT** and **ENTER** buttons to make your selections. Refer to the menu structure diagrams and accompanying table for guidance.

At any time during the calibration, you can **CANCEL**, restore your prior calibration and return to online mode, or **SAVE** your new calibration.

Figure 59 - Calibration Menu Structure (1 of 2)

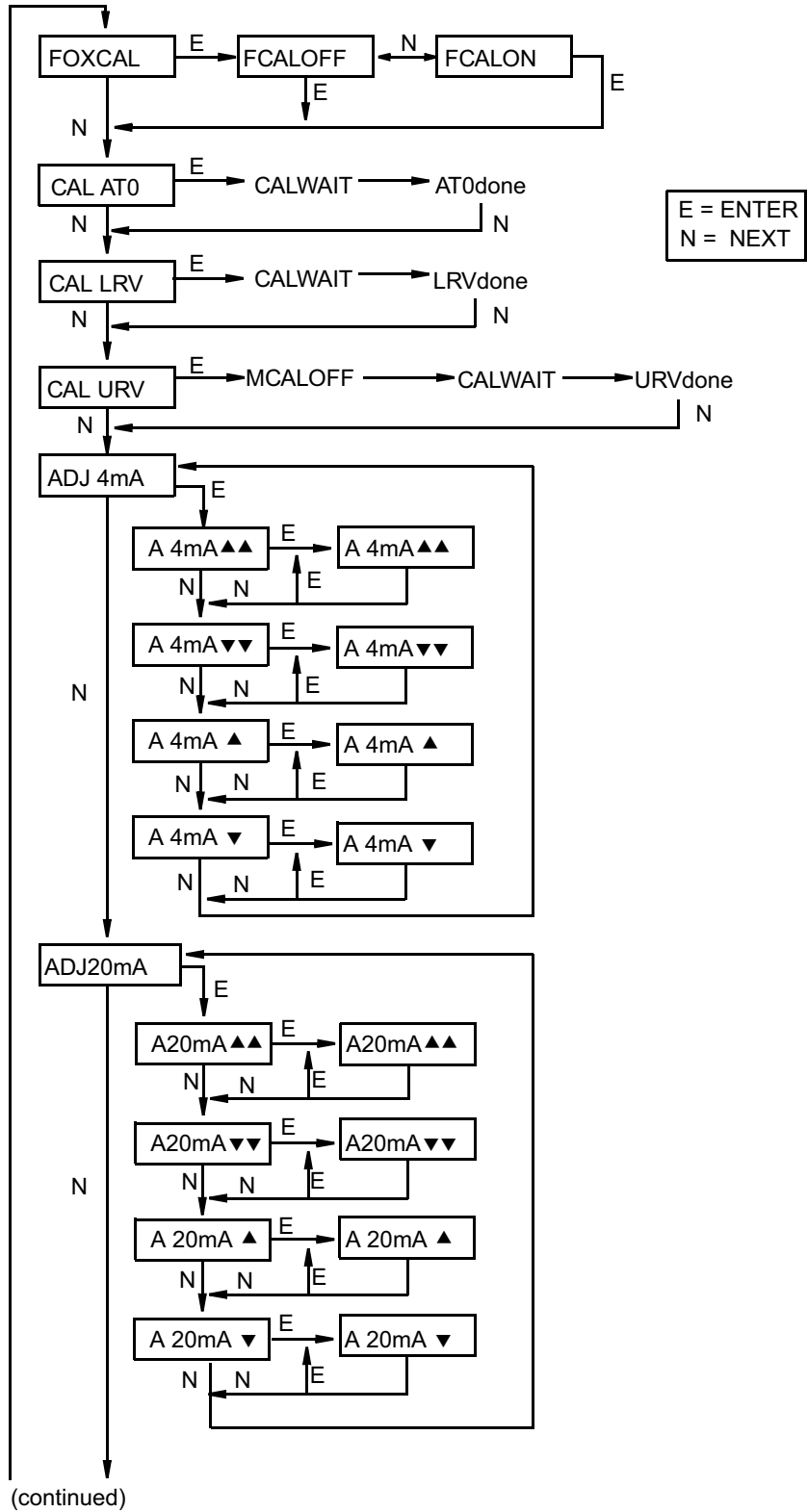

Figure 60 - Calibration Menu Structure (2 of 2)

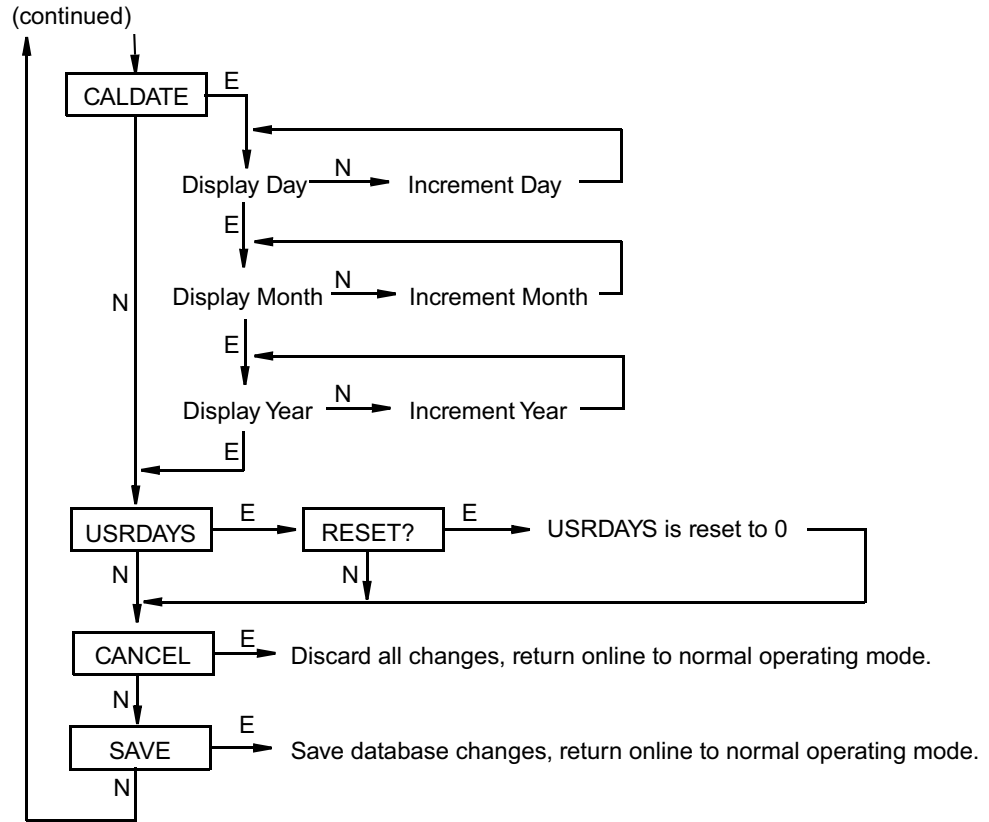

Table 12 - Calibration Menu Items

Item	Description
FOXCAL	This menu option allows you to enable or disable the FoxCal™ multiple calibration feature. To enable FoxCal™ calibrations, select FOXCAL from the CALIB menu, and then select FCALON . Similarly, to disable FoxCal™, select FCALOFF .
CAL AT0⁴⁸	This menu option calibrates the transmitter at zero pressure. To set or reset the zero point at zero pressure, apply zero pressure to the transmitter. When CAL AT0 appears on the display, press ENTER . This can be done whether LRV is zero or not. When the process is complete, AT0done appears on the display.
CAL LRV	This menu option calibrates the transmitter at 0% of the transmitter's range (LRV). To set or reset 0% of range input, apply pressure to the transmitter equal to the lower range value (LRV) in the transmitter database. When CAL LRV appears on the display, press ENTER . CALWAIT appears on the display while the calibration is taking place. LRVdone appears when the process is complete.
CAL URV	This menu option calibrates the transmitter at 100% of the transmitter's upper range value (URV). To set or reset 100% of range input, apply pressure to the transmitter equal to the upper range value (URV) in the transmitter database. When CAL URV appears on the display, press ENTER . NOTE: If FoxCal™ was enabled prior to starting the calibration, the CAL URV process will disable it and display FCALOFF . CALWAIT appears on the display while the calibration is taking place. URVdone appears when the process is complete.

48. This function is not applicable to absolute pressure transmitters.

Table 12 - Calibration Menu Items (Continued)

Item	Description
ADJ 4mA⁴⁹	This menu option adjusts the nominal 4 mA output. If you configured your transmitter operating mode as 4 to 20 mA, you can adjust the 4 mA output by going to ADJ 4mA using the NEXT button and pressing ENTER . These adjustment menu options are not available when the output is fixed at 4 mA (that is, when LOOP MD is set to MA DIS).
A 4mA ▲▲	Increases 4 mA output by a large (0.095 mA) step.
A 4mA ▼▼	Decreases 4 mA output by a large (0.095 mA) step.
A 4mA ▲	Increases 4 mA output by a small (0.003 mA) step.
A 4mA ▼	Decreases 4 mA output by a small (0.003 mA) step.
ADJ20mA⁴⁹	This menu option adjusts the nominal 20 mA output. If you configured your transmitter operating mode as 4 to 20 mA, you can adjust the 20 mA output by going to ADJ20mA using the NEXT button and pressing ENTER . These adjustment menu options are not available when the output is fixed at 4 mA (that is, when LOOP MD is set to MA DIS).
A20mA ▲▲	Increases 20 mA output by a large (0.095 mA) step.
A20mA ▼▼	Decreases 20 mA output by a large (0.095 mA) step.
A20mA ▲	Increases 20 mA output by a small (0.003 mA) step.
A20mA ▼	Decreases 20 mA output by a small (0.003 mA) step.
CALDATE	This menu option allows you to enter the calibration date. This entry is not required, but it can be used for record-keeping or plant maintenance purposes. To edit the calibration date, go to CALDATE with the NEXT button and press ENTER . You then can change the day, month, and year. The display shows the last date with the day flashing. Use the NEXT button to step through the menu of digits to select the desired day, then press ENTER . Repeat this process for the month and year.
USRDAY	The Time in Service meter tracks the number of days the pressure transmitter has been in service since the last Time in Service meter reset. For example, you can reset the Time in Service meter to 0 when the transmitter is calibrated. Reset the number of days the transmitter has been in service by navigating to USRDAY with the NEXT button.

Messages

The following calibration-related messages may appear on the optional display.

Parameter	Condition Tested	Message	Description
Password Protection	Password	BAD PWD	Bad password entered; use another.
Write Protection	Write protection enabled	REJECT	User attempted an action that is write protected.
ZERO	Internal offset too large	BADZERO	Check applied pressure, configured M1_LRV , and configured M1EOFF .
SPAN	Slope too large or too small	BADSPAN	Check applied pressure, configured M1_LRV , and configured M1EFAC .

49. It is not necessary to use the **ADJ 4mA** and **ADJ20mA** menu selections (also known as “trim”) unless there is a plant requirement to make the 4 and 20 mA output values exactly match the readings on certain plant calibration equipment, and the calibration operations result in a small but unacceptable difference between the transmitter’s output values and the test equipment’s readout values.

Parameter	Condition Tested	Message	Description
M1_URV	M1_URV >max pressure in EGU	URV>FMX	Entered pressure is greater than the maximum rated pressure of the transmitter. Check entry. Verify EGUs.
	M1_URV <min pressure in EGU	URV<FMN	Entered pressure is less than the minimum rated pressure of the transmitter. Check entry. Verify EGUs.
	M1_URV = M1_LRV	LRV=URV	Cannot set span to 0. Check entry. Check M1_LRV .
	M1 turndown exceeds limit	BADTDWN	Check entry. Check M1_LRV .
	URV <0 with M1 SqRt or M2 SqRt	URV<LRV ⁵⁰	Square root mode with nonzero LRV is not valid. Change LRV to 0.
M1_LRV	M1_LRV >max pressure in EGU	LRV>FMX	Entered pressure is greater than the maximum rated pressure of the transmitter. Check entry. Verify EGUs.
	M1_LRV <min pressure in EGU	LRV<FMN	Entered pressure is less than the minimum rated pressure of the transmitter. Check entry. Verify EGUs.
	M1_URV = M1_LRV	LRV=URV	Cannot set span to 0. Check entry. Check M1_URV .
	M1 turndown exceeds limit	BADTDWN	Check entry. Check M1_URV .

Using the External Zero Button

Transmitters with HART offer an optional external zero adjustment mechanism in the electronics housing. This mechanism allows calibration at zero pressure (the **CAL AT0** function, for GP and DP transmitters) or at the lower range value pressure (the **CAL LRV** function) without removing the electronics compartment cover. The mechanism is magnetically activated through the housing wall to help prevent moisture from entering the enclosure.

NOTE: Do not use **CAL AT0** if pressure seals are used that are at different elevations than the transmitter.

Figure 61 - Optional External Zero Button

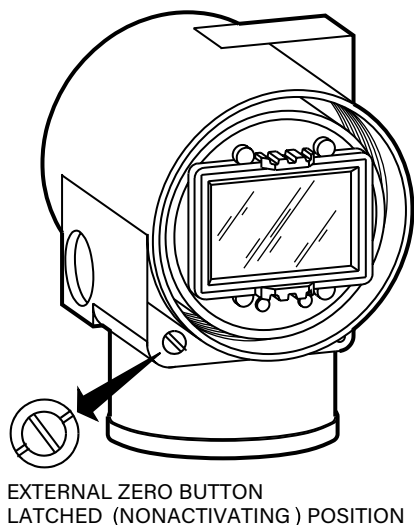

50. DP transmitters only.

Zero Adjustment for Transmitters with the Optional Display

1. Unlatch the external zero button by turning it 90 degrees in a counterclockwise direction so that the screwdriver slot lines up with the two holes in the face of the adjacent part. Do not push the button with the screwdriver while doing this.
2. To set or reset using the optional display:
 - a. To set or reset the zero point at zero pressure, apply zero pressure to the transmitter or (for DP transmitters) use a bypass valve to equalize pressure on both sides of the transmitter. Press the external zero button until the display reads **CAL AT0**. Release the button. The display reads **CALWAIT**.
When the display reads **AT0done**, calibration is complete.
 - b. To set or reset the 0% of range input, apply the lower range value (LRV) pressure to the transmitter and press and hold the external zero button until the display reads **CAL LRV** (it reads **CAL AT0** first). Release the button. The display reads **CALWAIT**.
When the display reads **LRVdone**, calibration is complete.
 - c. If additional rezeroing is required, repeat this step.

Other possible messages are:

 - **DISABLD**, if **EX ZERO** is configured as **EXZ DIS**.
 - **EXZ DIS IGNORED**, if the transmitter is not in the on-line mode.
 - **WP ENAB**, if the write protection jumper is in write protect position.
3. Relatch the external zero button by turning it 90 degrees in a clockwise direction to avoid pressing the button accidentally. Do not push the button with the screwdriver while doing this.

Zero Adjustment for Transmitters without the Optional Display

If the optional display is not present, you can accomplish the same functions by pressing the external zero button for different lengths of time. Pressing the button for 1 to 3 seconds allows you to execute a **CAL AT0**; pressing the button for 5 or more seconds allows you to execute a **CAL LRV**.

NOTICE

POTENTIAL MISCONFIGURATION

Use care when using the external zero button without the optional display. You must rely strictly on the length of time you press and hold the external zero button to distinguish between **CAL AT0** and **CAL LRV**.

Failure to follow these instructions can result in misconfiguration.

1. Unlatch the external zero button by turning it 90 degrees in a counterclockwise direction so that the screwdriver slot lines up with the two holes in the face of the adjacent part. Do not push the button with the screwdriver while doing this.

2. To set or reset using only the external zero button:
 - a. To set or reset the zero point at zero pressure, apply zero pressure to the transmitter or (for DP transmitters) use a bypass valve to equalize pressure on both sides of the transmitter. Press the external zero button for 1 to 3 seconds, then release the button.
 - b. To set or reset 0% of range input, apply the lower range value (LRV) pressure to the transmitter. Press and hold the external zero button for at least 5 seconds, then release the button.
 - c. If additional rezeroing is required, repeat this step.
3. Relatch the external zero button by turning it 90 degrees in a clockwise direction to avoid pressing the button accidentally. Do not push the button with the screwdriver while doing this.

Calibration Using a PC50

To calibrate the transmitter using a PC50 Configurator, follow the procedures in MI 020-520.

Calibration Using a HART Communicator

To calibrate the transmitter using a HART Communicator, follow the procedures in *Using the HART Communicator*, page 89.

Using the HART Communicator

You can use a HART Communicator to configure, operate, and calibrate these pressure transmitters.

Connecting the Communicator to the Transmitter

Connect the HART communicator to the transmitter as described in *Calibration Setup*, page 77. Also refer to the manual supplied with the communicator.

Operation

The value of the primary variable in engineering units (**PV**), the output value of the primary variable in mA (**PV Loop Current**), the primary variable lower range value (**LRV**), and the primary variable upper range value (**URV**) are displayed in the main menu.

Valid Characters for the HART Communicator

Alphanumeric Characters		Numeric Characters
@	'	
, (comma)	(- (minus sign)
A-Z (uppercase))	. (decimal point)
[*	0
]	+	1
\	- (hyphen)	2
^	. (period)	3
_ (underscore)	/	4
(space)	0-9	5
!	:	6
"	;	7
#	<	8
\$	>	9
%	=	
&	?	

Online Configuration

To configure your online transmitter with the communicator:

1. Connect the HART Communicator to the transmitter loop.
2. Select **1 Device Setup** from the Online menu.
3. Select **3 Basic Configuration** or **4 Full Configuration** from the next menu.

4. If you selected **4 Full Configuration**, select **1 View Parameters** to view existing parameters, or **2 Edit Parameters** to edit one or more parameters.

Figure 62 - Online Configuration Flowchart

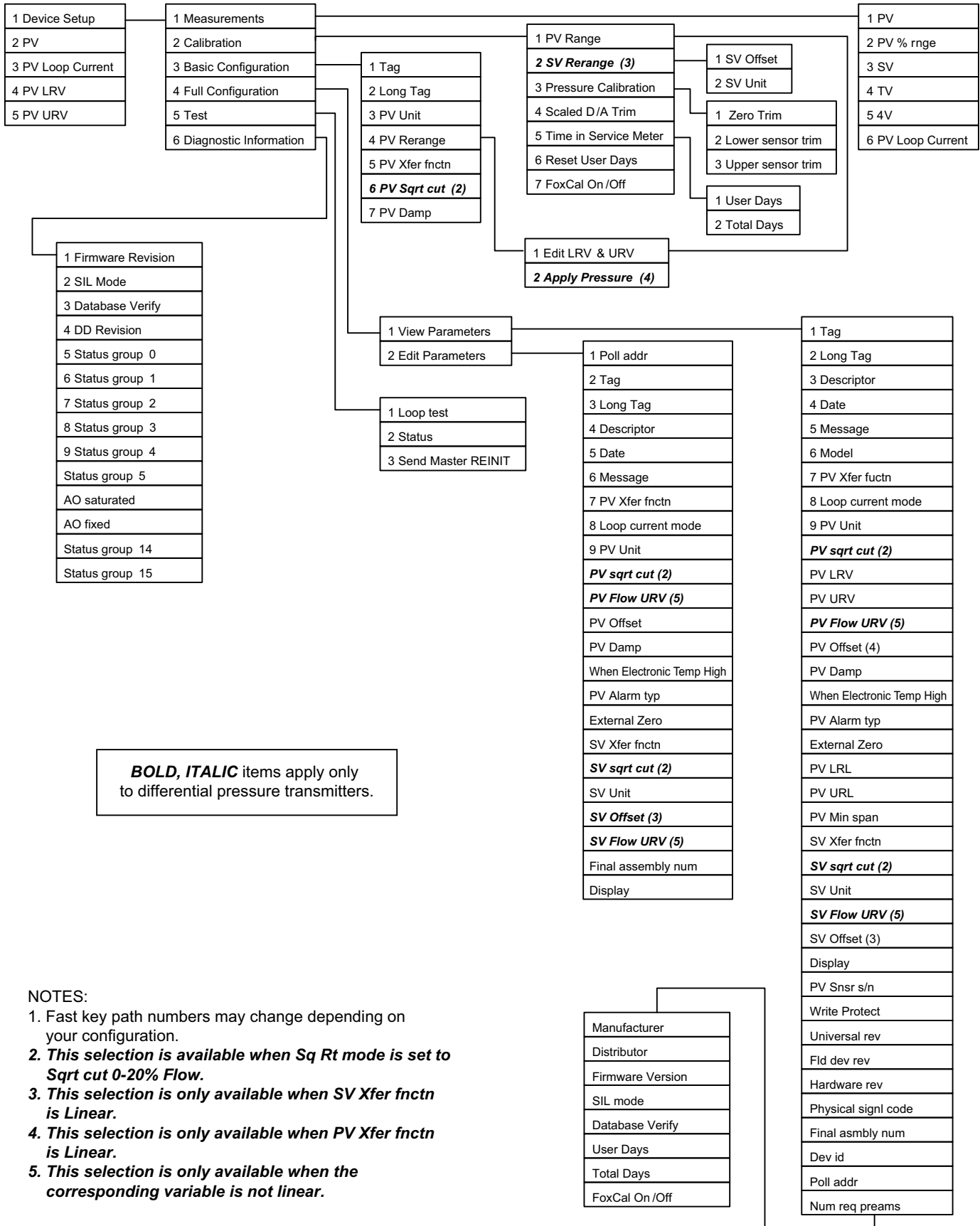

BOLD, ITALIC items apply only to differential pressure transmitters.

- NOTES:
1. Fast key path numbers may change depending on your configuration.
 2. This selection is available when *Sq Rt mode is set to Sqrt cut 0-20% Flow.*
 3. This selection is only available when *SV Xfer fnctn is Linear.*
 4. This selection is only available when *PV Xfer fnctn is Linear.*
 5. This selection is only available when the corresponding variable is not linear.

Table 13 - Online Parameters

Parameter	Description
AO Fixed	Analog Output is set to fixed value (4 mA) when Loop Current Mode is set to fixed (multidrop mode).
AO Saturated	The mA current signal is saturated at either the low or high overrange limit (3.8 mA or 20.5 mA, respectively).
Apply Pressure	This reranging function requires the application of pressure. The purpose of this function is to allow the transmitter to determine and change the values of the LRV and URV based on applied pressures.
Database Verify	Indicates whether the device is performing database verification actions that are required for SIL compliance.
Date	Date entered in the format mm/dd/yyyy.
DD Revision	Revision level of the device description.
Descriptor	The factory default is DESCRIPTOR . This parameter is normally configured as the tag name. The description is limited to 16 characters.
Dev id	Uniquely identifies the transmitter when combined with the manufacturer identification and device type.
Display	This feature allows you to select whether the optional local display will show M1 EGU (the primary measurement), M2 EGU (the secondary measurement), or TOGGLE between the two.
Distributor	The company responsible for the distribution of the transmitter to customers.
External Zero	The External Zero feature allows you to enable the optional external zero pushbutton or disable the button. The default is Disabled .
Final assembly num	Number associated with the overall transmitter.
Firmware version	Version of the transmitter firmware.
Fld dev rev	Revision level of the specific transmitter description.
FoxCal On/Off	Enables/disables the FoxCal™ calibration feature.
Hardware rev	Revision level of the hardware.
Long tag	The factory default is blank. This parameter is normally configured to the plant tag number. The long tag identifies the transmitter when using the HART communicator. The tag is limited to 32 characters.
Loop current mode	<p>Loop current mode can be Active or Fixed.</p> <p>When this parameter is set to Active, the transmitter operates in a standard point-to-point manner with a 4 to 20 mA output signal. When this parameter is Fixed, the transmitter's milliamp output is locked at a fixed value of 4.0 mA.</p> <p>If loop mode is fixed, the AO ALM, OUT DIR, OFFL MA, and mA adjustment selections will not be available from the menu structure after you save the configuration.</p>
Loop test	Procedure to use the transmitter as a calibration source to check other instruments in the loop.
Lower sensor trim	Lower sensor trim is for calibrating pressure at 0% of transmitter range (LRV).
Manufacturer	The company responsible for the manufacture of the transmitter.
Message	The factory default is MESSAGE . This parameter is normally configured as the instrument location. The message is limited to 32 characters.
Model	The model number of the transmitter.
Num req preams	Number of preambles to be sent in a request message from the transmitter to the host.
Physicl signl code	The type of physical layer that has been implemented in the hardware that is responsible for the HART communication port.
Poll addr	A number from 0 through 63.
Pressure Calibration	Calibration procedure using applied pressures.
PV	The primary variable is a dynamic digital value representing the process measurement in selected engineering units.
PV % rng	This is a variable that tracks digital value representation with regard to the range defined by the LRV and URV in normal operating modes.
PV Alarm typ	The user selection for the 4 to 20 mA output setting when a device alarm occurs, which can be either Hi (21.0 mA) or Lo (3.55 mA).

Table 13 - Online Parameters (Continued)

Parameter	Description
PV Damp	Output damping in seconds. Damping can be set to 0, 0.25, 0.5, 1, 2, 4, 8, 16, or 32 seconds.
PV Flow URV⁵¹	If PV Xfer fnctn is set to square root, this parameter shows the maximum flow rate value corresponding to the PV URV.
PV Loop Current	The PV Loop Current value tracks the digital value representation under normal operating mode.
PV LRL	Minimum usable value for PV LRV (lower sensor range limit).
PV LRV	Primary Lower Range Value in PV units.
PV Min span	Also known as the lower span limit, this is the smallest allowable difference between the URV and the LRV.
PV Offset	PV offset (does not change LRV and URV).
PV Rerange	Allows adjustment of 0 and 100% range values for the Primary Variable.
PV Snsr s/n	Serial number of the sensor from which the digital value representation or transmitter variable is primarily derived.
PV Sqrt Cut⁵¹	Set value of <i>n</i> if PV Xfer fnctn is Sqrt cut 0-20% Flow . This is a user entered value.
PV URL	Maximum usable value for PV URV (upper sensor range limit).
PV Unit	PV units (pressure units) when PV Xfer fnctn is linear: inH2O, ftH2O, mmH2O, inHg, mmHg, cmHg, mHg, psi, psf, mbar, bar, g/cm2, kg/cm2, kg/m2, Pa, hPa, kPa, MPa, torr, inWC60, ftWC60, inWC4, ftWC4, mmWC4, cmWC4, mWC4, atm, dy/cm2 PV units (flow units) when PV Xfer fnctn is square root: ⁵¹ gal/s, gal/m, gal/h, gal/d, Mgal/d, ft3/s, ft3/m, ft3/h, ft3/d, lgal/s, lgal/m, lgal/h, lgal/d, l/s, l/m, l/h, Ml/d, m3/s, m3/m, m3/h, m3/d, Nl/h, Nm3/h, Sm3/h, Am3/h, Sft3/m, MSCFD, MMSCFD, bbl/s, bbl/m, bbl/h, bbl/d, g/s, g/m, g/h, kg/s, kg/m, kg/h, kg/d, lb/s, lb/m, lb/h, lb/d, t/h, t/d, STon/m, STon/h, STon/d, LTon/h, LTon/d, %flow
PV URV	Primary Upper Range Value in PV units.
PV Xfer fnctn	Primary Variable Transfer Function (Linear , Sqrt cut<1% DP , Sqrt lin<4% DP , or Sqrt cut 0-20% Flow).
Reset User Days	Allows you to reset User Days (the number of days the transmitter has been powered up since the last Time in Service meter reset) back to zero.
Scaled D/A trim	Calibration procedure to match the 4 to 20 mA output to the calibration of the receiving device.
Send Master REINIT	Procedure to send a command to re-initialize the transmitter.
SIL Mode	Read-only status that indicates whether the device is performing the verification activities that are required for SIL compliance: <ul style="list-style-type: none"> • SIL Required and Active: The electronics support SIL operation. • SIL Available and Active: The electronics support SIL operation even though the transmitter's model code indicates that SIL is not required. • SIL Required but not Active: The electronics do not support SIL operation even though the transmitter's model code indicates that SIL is required. Contact Global Customer Support if this message is displayed. • SIL Not Available: The electronics do not support SIL operation. Contact Global Customer Support if this message is displayed.
Status	Indicates whether the device has detected abnormal operating conditions within the hardware or related to the validity of internal variables.
Status group 0-5	Status groups 0, 1, 2, 3, 4, and 5 consist of conditions related to communications, various device modes, diagnostic messages, input range messages, hardware messages, and alarms.
Status group 14-15	Status groups 14 and 15 consist of conditions related to communications, database verification, SIL mode, verification, etc.
SV	The secondary variable is an alternate value representing the process measurement in selected engineering units.
SV Flow URV⁵¹	If SV Xfer fnctn is set to square root, this parameter shows the maximum flow rate value corresponding to the PV URV.
SV Offset	SV offset. This is a user-entered value.
SV Rerange	Allows adjustment of SV Offset and SV Unit for Secondary Variable.

51. Differential pressure transmitters only.

Table 13 - Online Parameters (Continued)

Parameter	Description
SV Sqrt Cut ⁵²	Set value of n if SV Xfer fnctn is Sqrt cut 0-20% Flow . This is a user entered value.
SV Unit	SV units (pressure units) when SV Xfer fnctn is linear: inH ₂ O, ftH ₂ O, mmH ₂ O, inHg, mmHg, cmHg, mHg, psi, psf, mbar, bar, g/cm ² , kg/cm ² , kg/m ² , Pa, hPa, kPa, MPa, torr, inWC60, ftWC60, inWC4, ftWC4, mmWC4, cmWC4, mWC4, atm, dy/cm ² SV units (flow units) when SV Xfer fnctn is square root: ⁵² gal/s, gal/m, gal/h, gal/d, Mgal/d, ft ³ /s, ft ³ /m, ft ³ /h, ft ³ /d, lgal/s, lgal/m, lgal/h, lgal/d, l/s, l/m, l/h, Ml/d, m ³ /s, m ³ /m, m ³ /h, m ³ /d, Nl/h, Nm ³ /h, Sm ³ /h, Am ³ /h, Sft ³ /m, MSCFD, MMSCFD, bbl/s, bbl/m, bbl/h, bbl/d, g/s, g/m, g/h, kg/s, kg/m, kg/h, kg/d, lb/s, lb/m, lb/h, lb/d, t/h, t/d, STon/m, STon/h, STon/d, LTon/h, LTon/d, %flow
SV Xfer fnctn	Secondary Variable Transfer Function (Linear , Sqrt cut<1% DP , Sqrt lin<4% DP , or Sqrt cut 0-20% Flow).
Tag	The factory default is TAG . This parameter is normally configured to the plant tag number. The Tag is the primary identifier when communicating with a transmitter using the HART communicator. It is limited to eight characters.
Time in Service Meter	There are two ways to track the time that a transmitter has been in service. Total Days is a non-configurable value that represents the number of days the transmitter has been powered up in the field over its lifetime; User Days is the number of days the transmitter has been powered up since the last Time in Service Meter reset.
Total Days	This parameter allows you to view the number of days that a transmitter has been powered up in the field in its entire lifetime.
TV	The tertiary (third) value is a digital representation of the approximate sensor temperature, which is used internally to compensate pressure calculations.
Universal rev	Revision level of the Universal Device Description that the transmitter conforms to.
Upper sensor trim	Upper sensor trim is for calibrating pressure at 100% of transmitter range (URV).
User Days	The number of days the transmitter has been powered up since the last Time in Service Meter reset.
When Electronic Temp High	The "bad sensor strategy" for the electronics temperature sensor can be set to AO Alarm or Use Default .
Write protect	No or Yes . Indicates whether variables can be written to the transmitter, and whether commands that cause actions to be performed in the transmitter can occur.
Zero trim	Calibration procedure to make the sensor input the new zero input reference. Zero trim does not affect span.
4V	The fourth value is a digital representation of the approximate electronics module temperature.

Calibration

PV Rerange

PV Rerange sets new values for the LRV and URV, which correspond to the 4 mA and 20 mA output values, respectively. The 4 to 20 mA output signal is always linked to the primary value (PV).

Two selections are provided for reranging the PV. Neither selection affects the calibration of the transmitter.

- **Edit LRV URV**

This function allows you to enter new known values for the LRV and URV. For example, use this function to change the range from "0 to 200 inH₂O" to "0 to 100 inH₂O." The LRV and URV can be edited independently:

- Changing the LRV does not affect the URV; changing the URV does not affect the LRV.
- Changing either value alone changes the span.

52. Differential pressure transmitters only.

This reranging function does not require the application of pressure. If the transmitter has pressure applied, this pressure is not used for the rerange function and does not affect the result.

- **Apply Pressure**

This function allows the transmitter to determine and change the values of the LRV and URV based on applied pressures. Use this function if the range of the transmitter is to be reset to unknown values. For example, if the liquid level in a tank is brought to the minimum level that will correspond with the new LRV (4 mA point), this function enables the transmitter to rewrite its LRV and provide a 4 mA output at that level. Similarly, if the level is brought to the maximum level, this function enables the transmitter to rewrite its URV and provide a 20 mA outputs at that level.

- Changing the LRV automatically changes the URV by the same amount, keeping the span unchanged.
- Changing the URV has no effect on the LRV; thus, the span is changed.

NOTE: For DP transmitters, the **Apply Pressure** reranging option pertains to linear mode only.

PV Offset

When PV is in linear (pressure) mode, the **PV Offset** function is accessible from **1 Device Setup > 4 Full Configuration > 1 View Parameters** or **2 Edit Parameters**. Editing **PV Offset** causes both the PV and mA output to have an offset without changing either the LRV or URV.

For example, if a transmitter has a range of 0 to 100 inH₂O (LRV=0 and URV=100), entering a value of -10 for **PV Offset** causes the transmitter to provide a PV reading of 10 inH₂O and a current output of 5.6 mA when applied pressure is 0 inH₂O.

PV Flow URV

PV Flow URV⁵³ allows the entry of the maximum flow rate value corresponding to the PV URV and the 20 mA output.

When PV is in square root mode, the **PV Flow URV** function is accessible from **1 Device Setup > 4 Full Configuration > 2 Edit Parameters**. It is also automatically displayed in square root mode when PV units are changed.

SV Rerange

A DP transmitter that has PV in square root mode can have SV in linear mode; a DP transmitter that has PV in linear mode can have SV in square root mode. This allows easy checking of the measured differential pressure when a transmitter is configured for square root operation.

SV Rerange does not function like **PV Rerange**. Instead, it allows you to perform the **SV Offset** and **SV Flow URV** functions. **SV Offset** and **SV Flow URV** are similar to the corresponding PV functions. Refer to *PV Offset*, page 94 and *PV Flow URV*, page 94 for details.

Pressure Calibration

These transmitters are factory characterized and calibrated. There is usually no need to do a pressure calibration. Use the **Zero Trim** function to correct for position effects (see *Zero Trim*, page 95), or use **Rerange** to change the range (see *PV Rerange*, page 93 and *SV Rerange*, page 94). Your transmitter uses its factory entered and stored characterization and calibration data to convert any input pressure within range

53. Differential pressure transmitters only.

limits to a digital value of pressure which can be transmitted, displayed, and converted into a current signal.

However, if a pressure calibration is desired, use the **Pressure Calibration** function to trim the internal digital values of the interpreted pressures based on the precise values of the applied lower and upper range pressures. Apply a pressure to your transmitter that is equal to or near the LRV. Enter that pressure as the pressure for the lower trim point when requested. Similarly, apply a pressure equal to or near the URV, and enter that pressure for the upper trim point.

Also, it may sometimes be desirable to perform a single point calibration (zeroing) with a nonzero pressure input without affecting the span. For example, to zero an absolute pressure transmitter at a measured atmospheric pressure, use a trim point within the **Pressure Calibration** to achieve a single point calibration that does not change the span.

NOTICE

POTENTIAL REDUCED PERFORMANCE

The accuracy of the input pressure for field span calibration should be a minimum of four times better than the transmitter's reference accuracy specification. An inaccurate span pressure input typically results in degradation of transmitter performance from the factory calibrated state.

Failure to follow these instructions can result in reduced performance.

Zero Trim

Use this procedure to adjust the lower trim point to compensate for positioning effects. Set up the calibration equipment per your transmitter instruction (see *Calibration Setup*, page 77).

Zero Trim requires the application of zero pressure (or equal pressures on both sides of a differential pressure transmitter). The LRV does not have to be zero.

Do not use **Zero Trim** on an absolute pressure transmitter unless the transmitter has full vacuum applied.

Zero Trim has no effect on the LRV.

Scaled D/A Trim

You can trim the 4 to 20 mA output at 4 mA and 20 mA, or at other values by connecting a digital voltmeter and precision resistor in the output loop and adjusting the output with this procedure. Set up the calibration equipment as described in *Calibration Setup*, page 77.

Application of pressure is not required. This adjustment has no effect on the internal digital interpretation of pressure, nor on the displayed and transmitted digital values representing the applied pressures. It only trims the conversion of the digital values of pressure to the transmitted 4 to 20 mA analog signal.

NOTE: It is usually not necessary to use this procedure. However, in special cases, it can be used to eliminate minor differences between the transmitter mA output and plant test equipment mA readings.

Time in Service Meter

These transmitters have two ways of tracking the time that a transmitter has been in service:

- **Total Days** is a nonconfigurable value that represents the number of days the transmitter has been powered up in the field over its lifetime.

To view the number of days that a transmitter has been in the field, use the **1 Device Setup > 2 Calibration > Time in Service Meter** menu selection.

- **User Days** is the number of days the transmitter has been powered up since the last Time in Service meter reset.

You can reset the number of user days to zero at any time. For example, you may want to reset this value to zero when the transmitter is calibrated or reset.

To reset the number of days that the transmitter has been in service since the last Time in Service meter reset, use the **1 Device Setup > 2 Calibration > Reset User Days** menu selection.

Enabling and Disabling the FoxCal™ Calibration Feature

For the Advanced (10S) and Premium (50S) performance tiers, transmitters can be shipped with the FoxCal™ feature enabled. Refer to *FoxCal™ Multiple Calibration Technology*, page 74 for more information on this feature.

To turn FoxCal™ on or off, use the **1 Device Setup > 2 Calibration > FoxCal On/Off** menu selection.

NOTICE

POTENTIAL REDUCED PERFORMANCE

When disabling FoxCal™ calibration, the last two-point calibrated range may not match the current configuration of the Lower Range Value and Upper Range Value. For optimal performance, avoid large mismatches.

Failure to follow these instructions can result in reduced performance.

NOTE:

1. For best results in applications where high accuracy is required, rezero the transmitter output once it has stabilized at the final operating temperature.
2. Zero shifts that result from position effects can be eliminated by rezeroing the transmitter output.

After calibrating transmitters operating with a 4 to 20 mA output signal, check that the underrange output value is less than 4 mA and the overrange output value is greater than 20 mA.

Maintenance

WARNING

EXPLOSION HAZARD

- For nonintrinsically safe installations, to help prevent a potential explosion in a Division 1 hazardous area, de-energize transmitters before you remove the threaded housing covers.
- For explosion proof and non-incendive installations, do not disconnect equipment when a flammable or combustible atmosphere is present.

Failure to follow these instructions can result in death or serious injury.

Parts Replacement

For optimum transmitter performance, send the transmitter to the factory to replace parts. Removing the process covers may require recalibration of the transmitter.

Replacing the Terminal Block Assembly

To replace the terminal block assembly, follow these steps:

1. Turn off the transmitter power source.
2. Turn the cover lock screw (if applicable) clockwise to disengage the lock.
3. Remove the covers from the field terminals and electronics compartments by rotating the covers counterclockwise.
4. Remove the digital display (if applicable) by grasping the two tabs on the display and rotating it about 10° in a counterclockwise direction.
5. Remove the electronics module from the housing by loosening the two captive screws that fasten it to the housing. Then pull the module out of the housing far enough to gain access to the cable connectors on the rear of the module.
6. Remove the four socket head screws fastening the terminal block.
7. Disconnect the terminal block cable connector from the electronics module.
8. Remove the terminal block and the gasket under it.
9. Connect the new terminal block cable connector to the electronics module.
10. Install the new terminal block and new gasket. Reinstall the four screws and tighten them to a torque of 0.67 N-m (6 lbf-in) in several even increments.
11. Reinstall the electronics module (and digital display, if applicable).
12. Reinstall the covers onto the housing by rotating them clockwise to seat the o-ring into the housing. Continue to hand-tighten until each cover contacts the housing metal-to-metal.
13. If cover locks are present, lock the cover per the procedure described in *Cover Locks, page 44*.
14. Turn on the transmitter power source.

Replacing the Vent Plug

Figure 63 - Replacing the Vent Plug

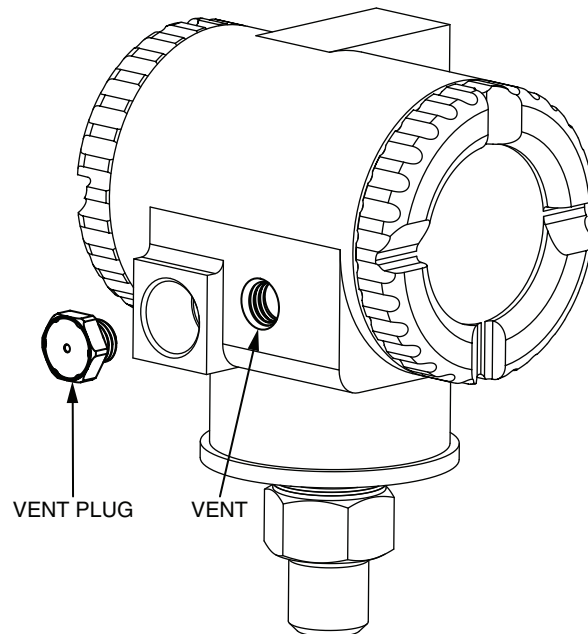

To replace the vent plug (gauge pressure transmitters only), refer to the diagram and follow these steps:

1. Remove the vent plug by unscrewing it counterclockwise.
2. Clean the angled sealing surface on the housing.
3. Lubricate the o-ring and the threads on the new plug with silicone lubricant (part number 0048130 or equivalent).
4. Install the new plug (part number X0179ME) into the housing by screwing it clockwise. Torque to 0.9 ± 0.02 N-m (8 ± 0.2 lbf-in).

Adding the Optional Display

Figure 64 - Adding the Optional Display

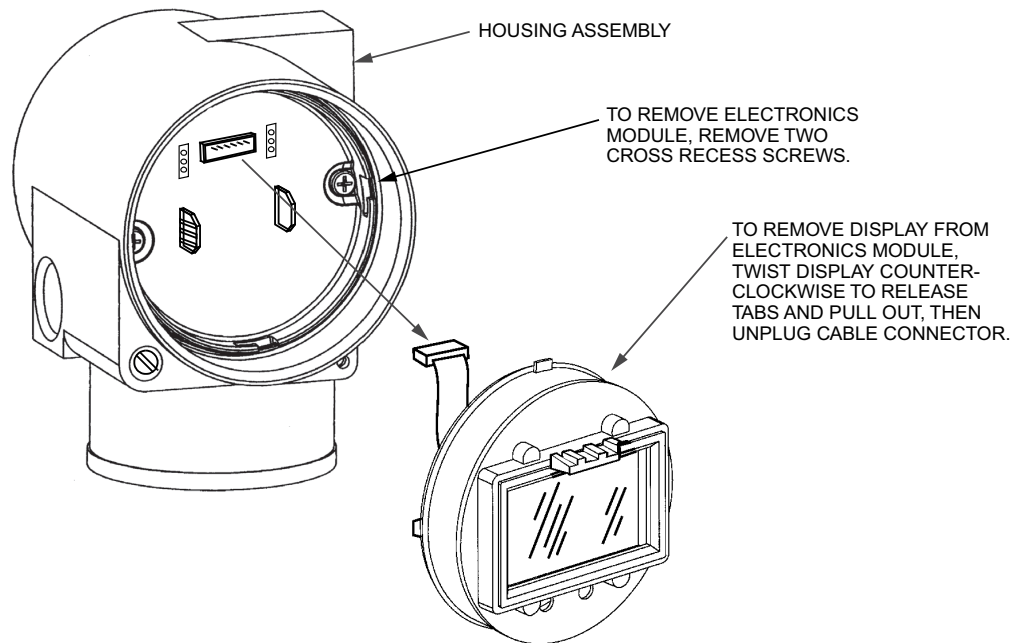

To add the optional display, refer to the diagram and follow these steps:

1. Turn off the transmitter power source.
2. Turn the cover lock screw (if applicable) clockwise to disengage the lock.
3. Remove the electronics compartment cover by rotating it counterclockwise.
4. Plug the display into the receptacle at the top of the electronics assembly.
5. Ensure that the o-ring is seated in its groove in the display housing. Then insert the display into the electronics compartment by grasping the two tabs on the display and rotating it about 10° in a clockwise direction.
6. Install the new, windowed cover onto the housing by rotating it clockwise to seat the o-ring into the housing. Continue to hand-tighten until the cover contacts the housing metal-to-metal.
7. If cover locks are present, lock the cover as described in *Cover Locks, page 44*.
8. Turn on the transmitter power source.

Rotating Process Covers for Venting

Your transmitter provides sensor cavity draining without the need for side drain connections, regardless of whether the transmitter is mounted vertically or horizontally. Sensor cavity venting is provided by mounting the transmitter horizontally or with the optional vent screw (option -V). If you do not have a vent screw, you can achieve venting (instead of draining) with vertical mounting by rotating the process covers.

NOTE: This procedure involves removing the process covers. You may need to recalibrate the transmitter afterwards.

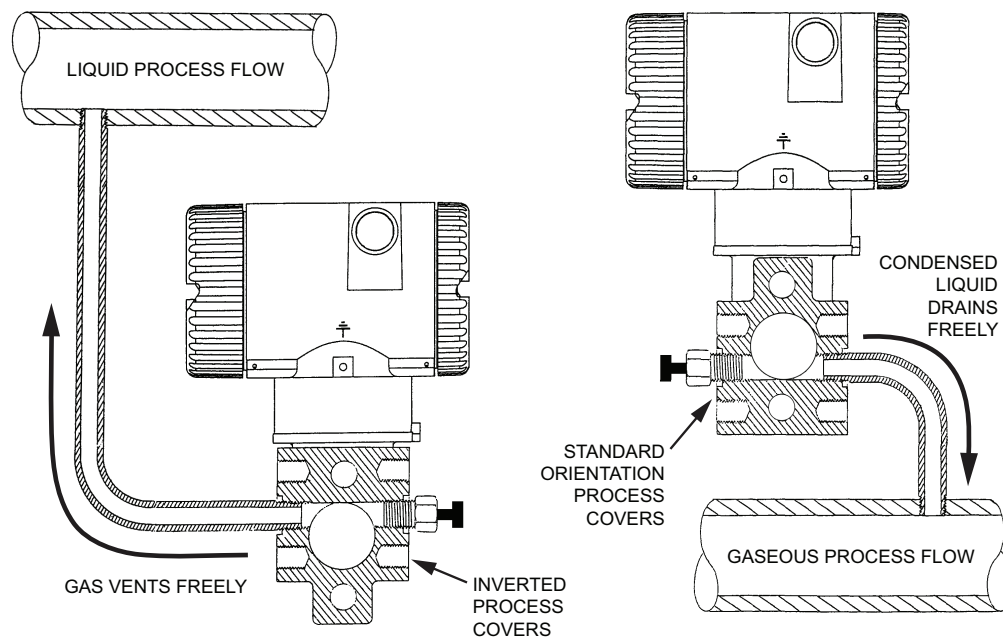
Figure 65 - Sensor Cavity Venting and Draining

To rotate the process covers, refer to the diagram and follow these steps:

1. Turn off the transmitter power source and remove the transmitter from the process.
2. Remove the process covers from the sensor by removing two hex head bolts.
3. Replace the gaskets in the process covers.
4. Rotate the process covers so that the longer tab is at the bottom.
5. Reinstall the process covers and bolts. Torque cover bolts to 100 N-m (75 lbf-ft) in several even increments. Torque values are 68 N-m (50 lbf-ft) for 316 ss bolts; 75 N-m (55 lbf-ft) for B7M bolts.
6. Pressure test the sensor and process cover assembly by applying a hydrostatic pressure of 150% of the maximum static and overrange pressure (see *Maximum Static, Overrange, and Proof Pressure Ratings, page 14*) to both sides of the process cover/sensor assembly simultaneously through the process connections. Hold pressure for one minute. There should be no leakage of the test fluid through the gaskets. If leakage occurs, re-tighten the cover bolts or replace the gaskets and retest.

▲ CAUTION

RISK OF POTENTIAL INJURY AND/OR REDUCED PERFORMANCE

Perform a hydrostatic test with a liquid, and follow proper hydrostatic test procedures.

Failure to follow these instructions can result in injury or reduced performance.

Dimensions

For dimensional information specific to your sales order, contact your sales representative to order a Certified Dimensional Print (CDP).

All dimensions in diagrams are shown in millimeters over inches ($\frac{mm}{in}$).

NOTE: For information on pulp and paper connection and sanitary pressure transmitters, see:

- DP 020-217, *Gauge and Absolute Pressure Transmitters With Pulp and Paper Process Connections*
- DP 020-218, *Sanitary Pressure Transmitters with 1½-, 2-, and 3-inch Tri-Clamp Process Connection*
- DP 020-219, *Sanitary Gauge or Absolute Pressure Transmitters with Mini Tank Spud Seal*

Direct Connect AP and Direct Connect GP Transmitters

Figure 66 - Direct Connect AP/GP Transmitters

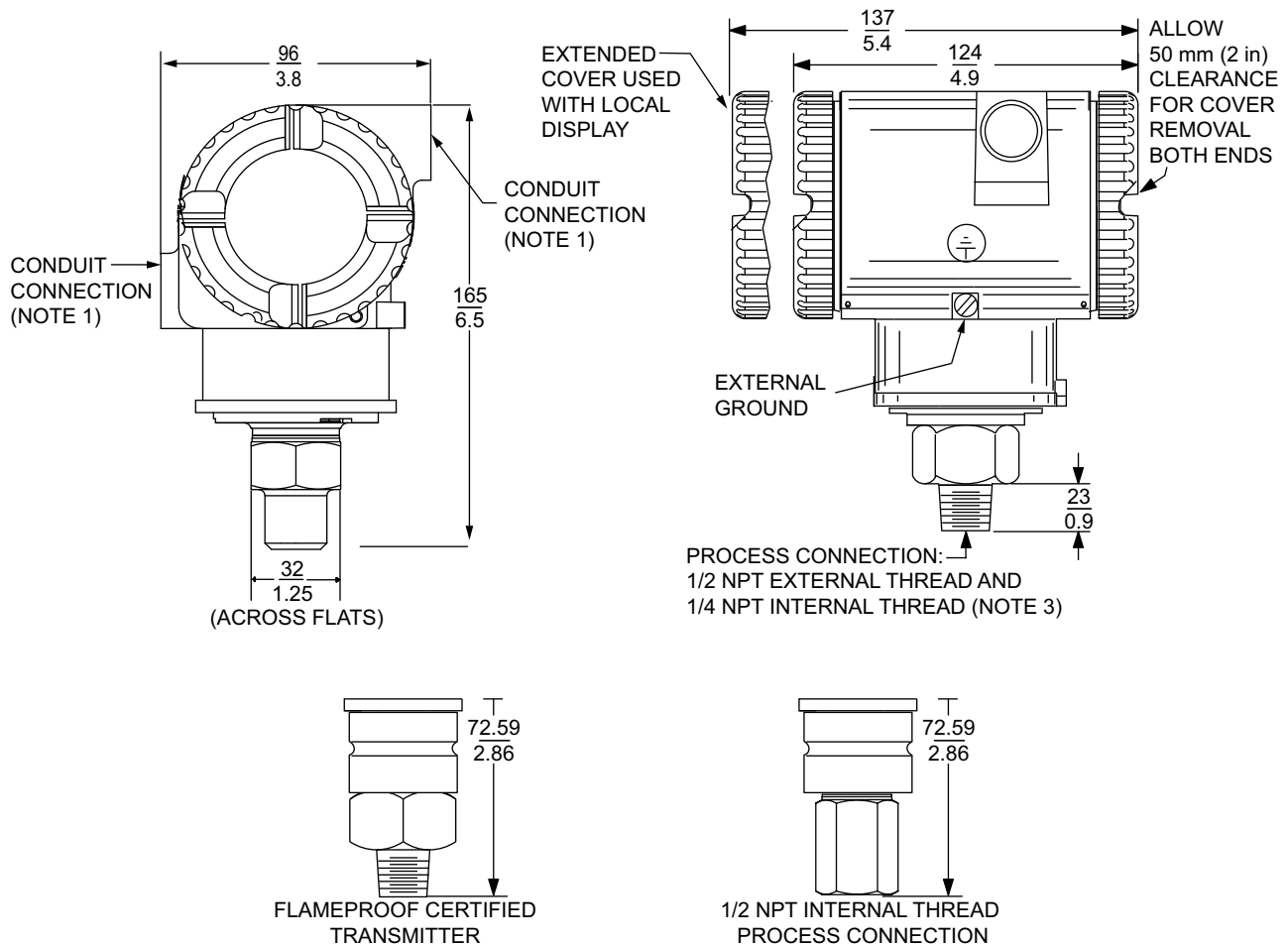

NOTES:

1. CONDUIT CONNECTION 1/2 NPT OR M20, BOTH SIDES: PLUG UNUSED CONNECTION WITH SUPPLIED METAL PLUG.
2. TOPWORKS ROTATABLE TO ANY POSITION WITHIN ONE TURN COUNTERCLOCKWISE OF FULLY TIGHTENED POSITION.
3. DO NOT USE THE 1/4 NPT INTERNAL THREAD TO DIRECTLY CONNECT THE TRANSMITTER.

Figure 67 - Direct Connect AP/GP Transmitters with Options -G, -V1, -V2, -V3, -V4, and -R

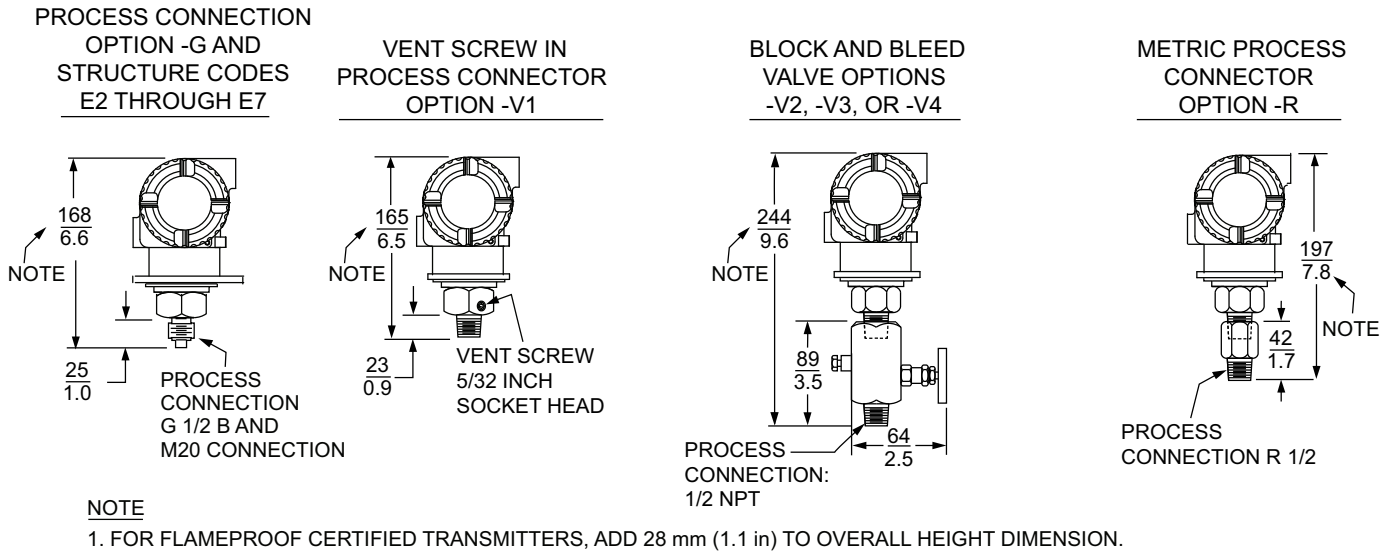

Figure 68 - Direct Connect AP/GP Transmitters with Options -M1, -M2, -M5, and -M6

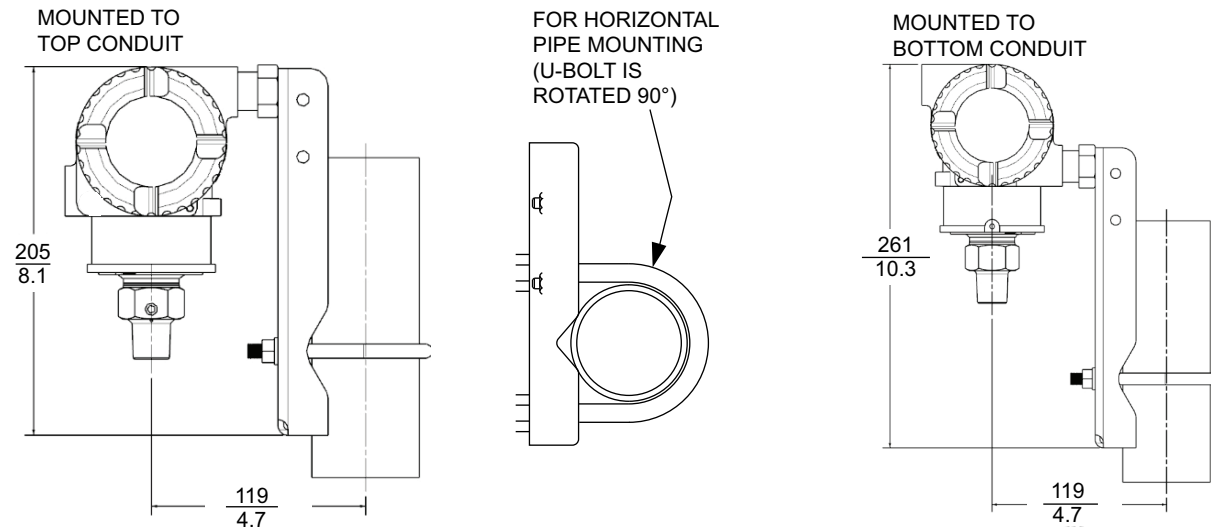

Figure 69 - Flameproof Direct Connect AP/GP Transmitters with Options -M7 and -M8

Figure 70 - Direct Connect GP Transmitters for High Gauge Pressure Measurement



Biplanar AP and Biplanar GP Transmitters

Figure 71 - Biplanar AP/GP Transmitters

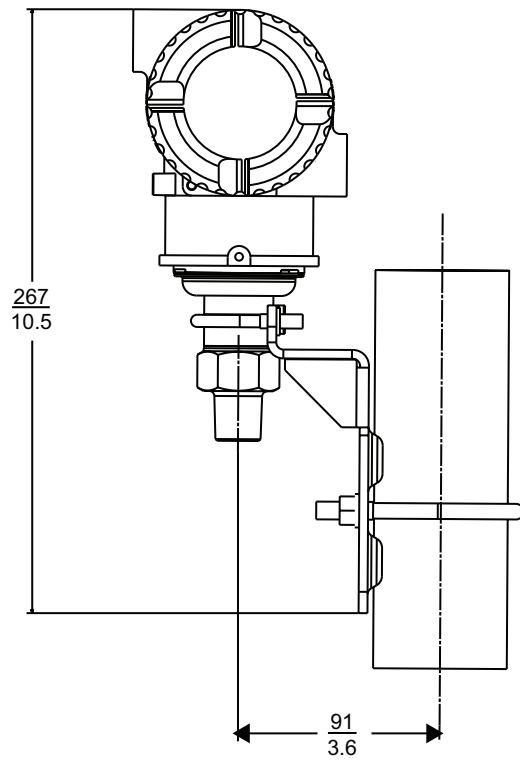
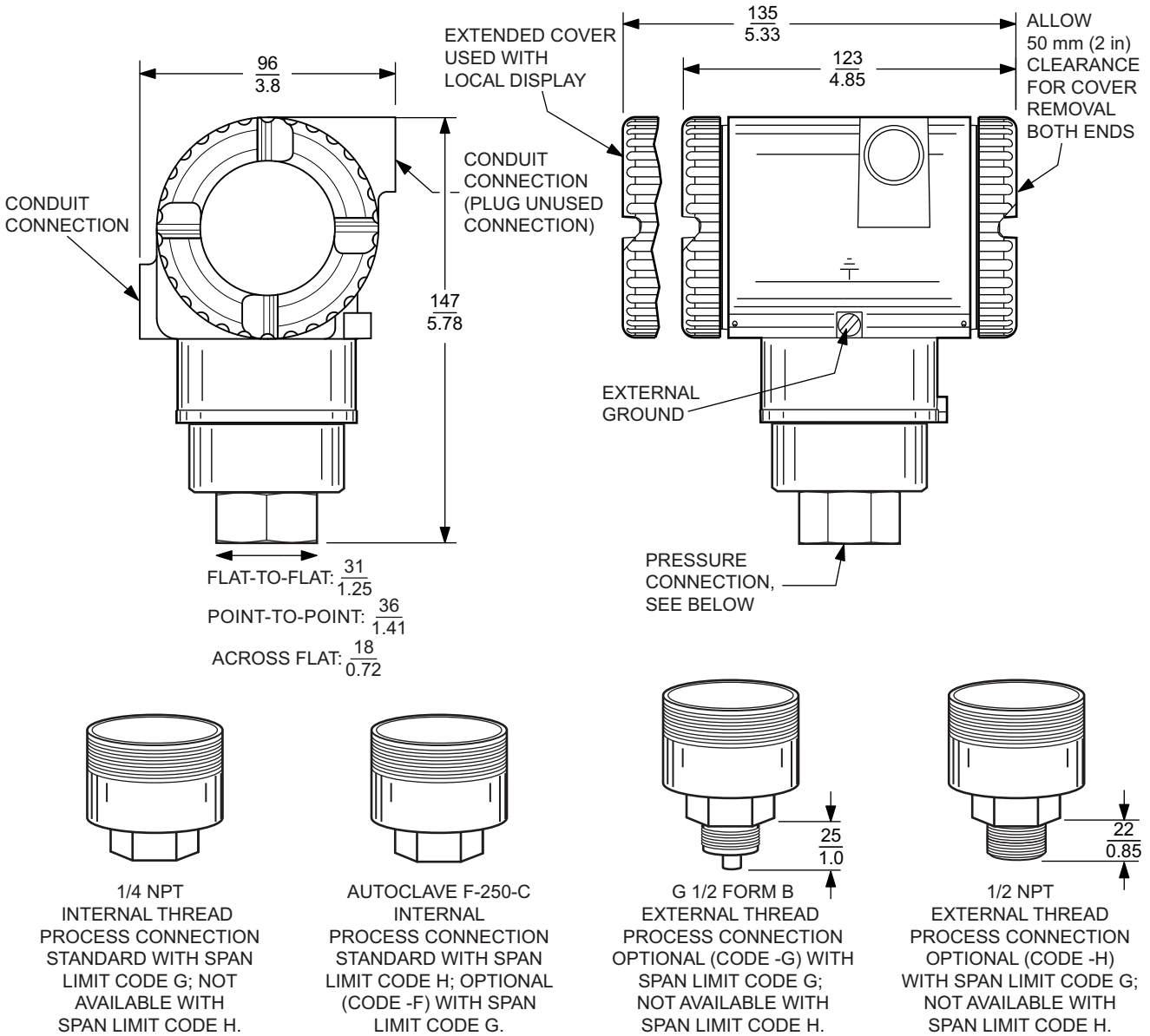
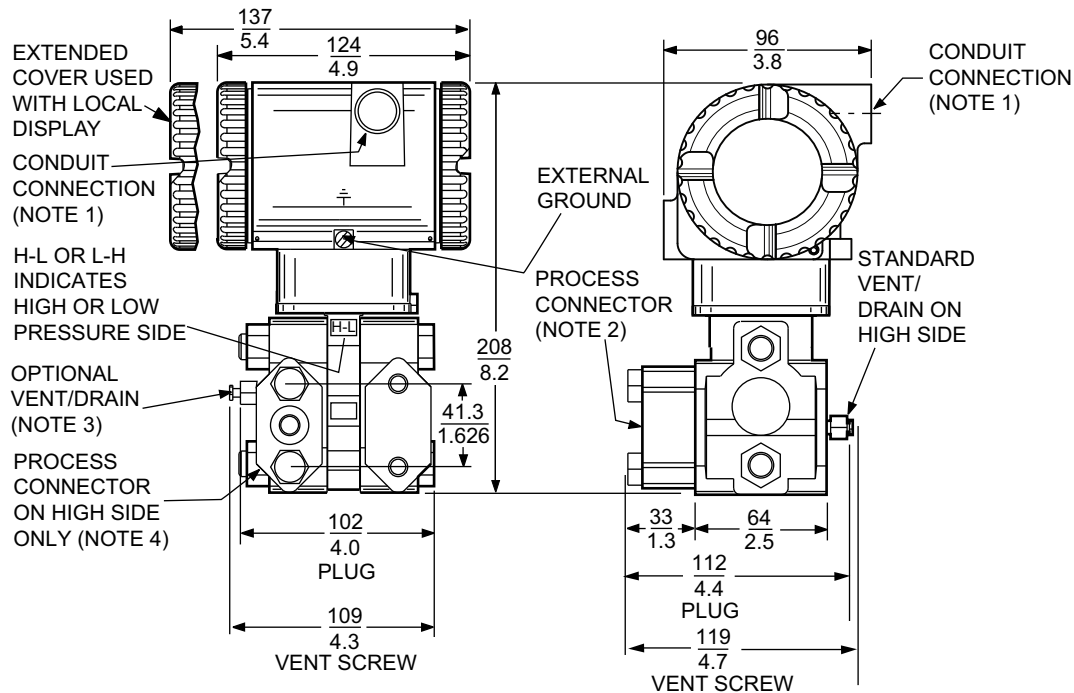

NOTES

1. CONDUIT CONNECTION 1/2 NPT OR M20, BOTH SIDES: PLUG UNUSED CONNECTION WITH SUPPLIED METAL PLUG.
2. PROCESS CONNECTOR CAN BE REMOVED AND CONNECTION MADE DIRECTLY TO PROCESS COVER USING 1/4 NPT INTERNAL THREAD IN PROCESS COVER. NOTE THAT WITH PROCESS CONNECTION CODE "0", THERE IS NO CONNECTOR.
3. PROCESS COVER CAN BE INVERTED MAKING OPTIONAL SIDE VENT A SIDE DRAIN.
4. FOR USERS WHO DESIRE THE PROCESS CONNECTOR ON THE RIGHT SIDE, ROTATE TRANSMITTER 180° AND RELOCATE PROCESS CONNECTOR (AND VENT SCREW, IF APPLICABLE).
5. DO NOT USE THE 1/4 NPT INTERNAL THREAD TO DIRECT-CONNECT THE TRANSMITTER WITHOUT A MOUNTING BRACKET.

Figure 72 - Biplanar AP/GP Transmitters with Options -D1, -D2, -D3, -D4, -D5, -D6, -D7, -D8, and -D9

IEC 61518 CONSTRUCTION OPTIONS

SINGLE ENDED PROCESS COVER OPTIONS	DOUBLE ENDED PROCESS COVER OPTIONS
-D1, -D3, -D5, -D7, -D9	-D2, -D4, -D6, -D8

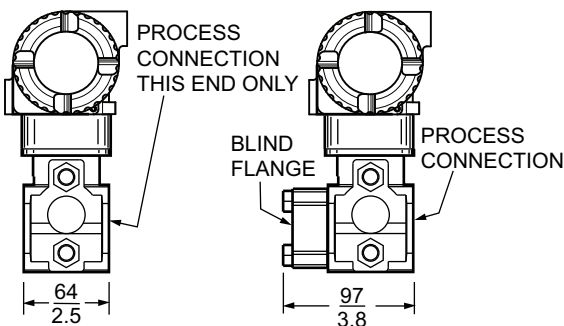

Figure 73 - Biplanar AP/GP Transmitters with Options -M0 and -M9 (Standard Stainless Steel or Painted Steel Bracket)

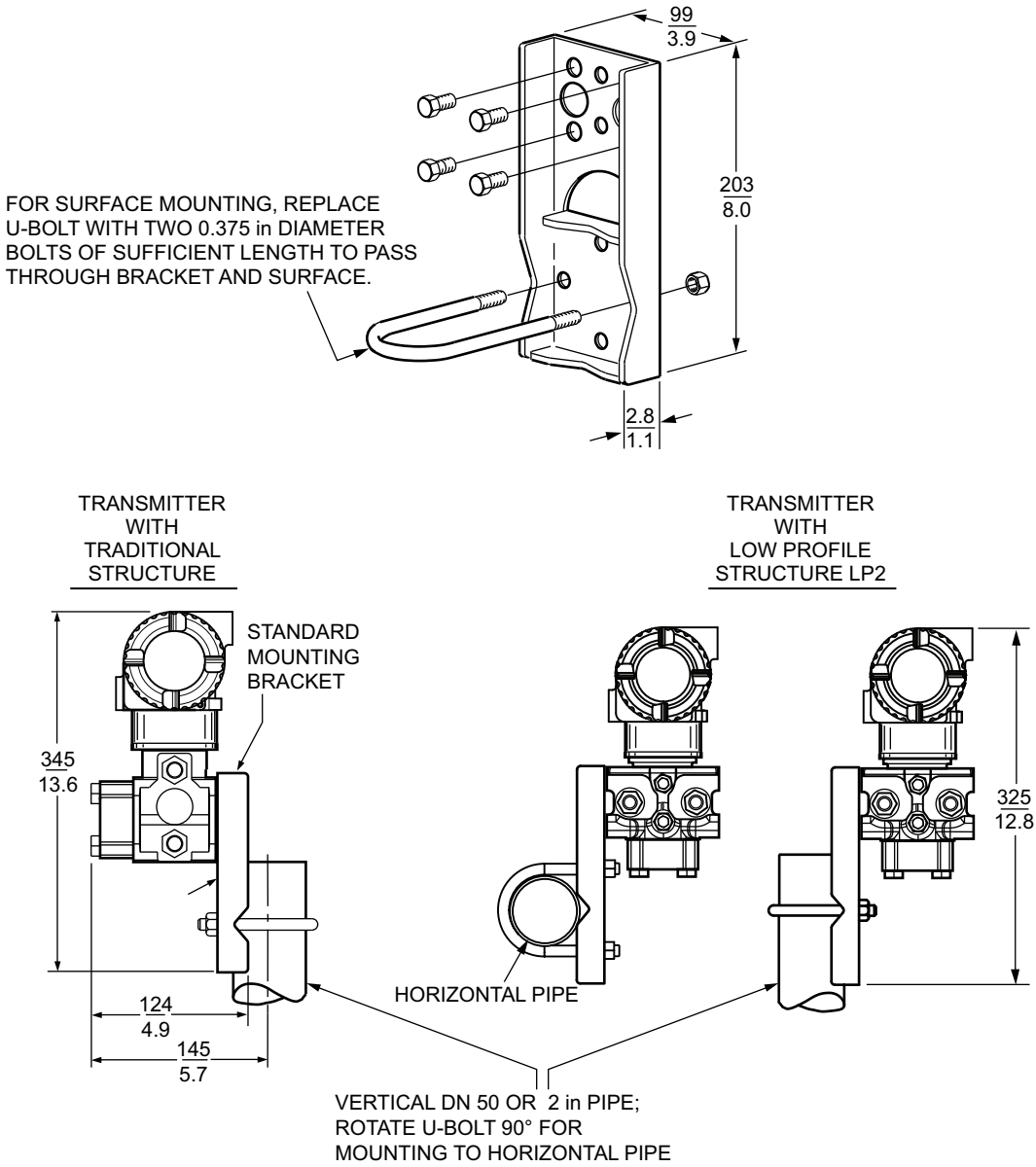
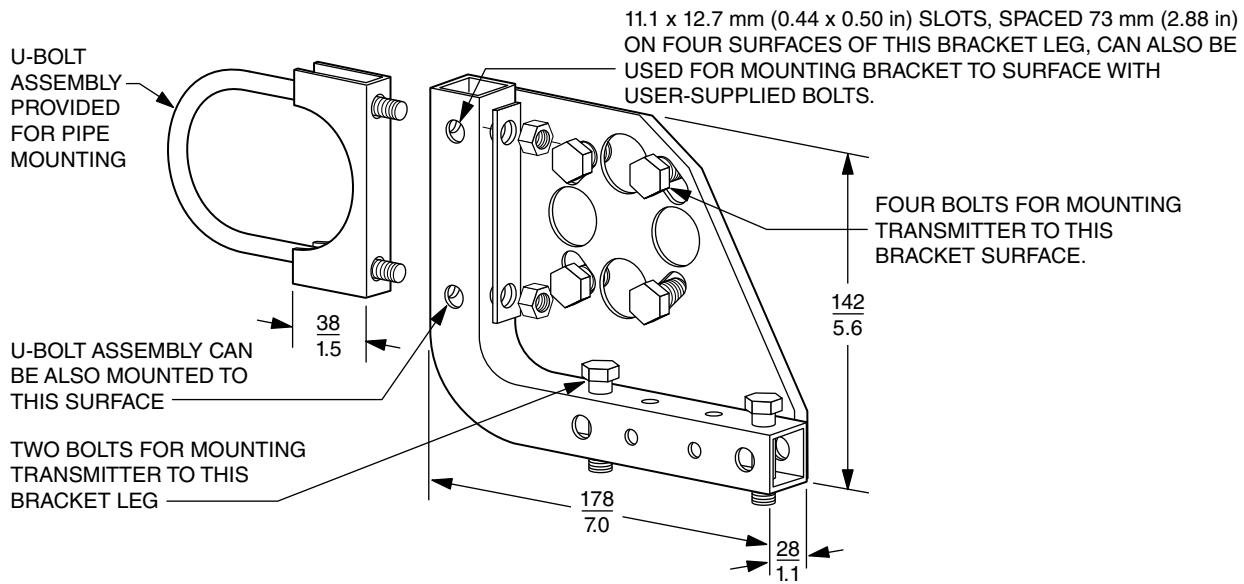
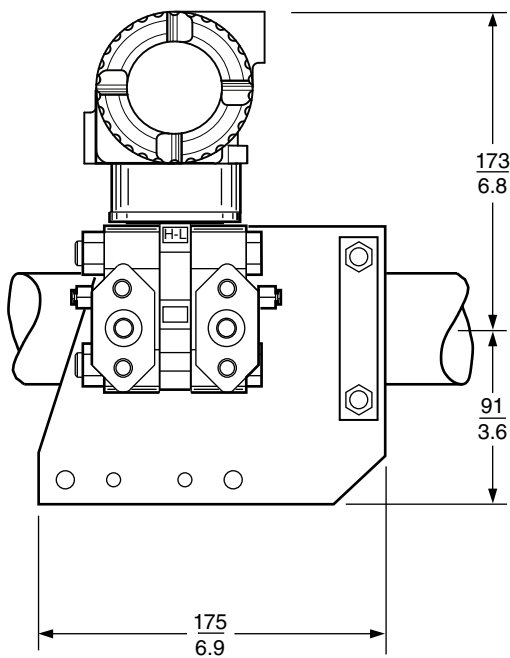

Figure 74 - Biplanar AP/GP Transmitters with Option -M3 (Universal Bracket)



HORIZONTAL PIPE MOUNTING



VERTICAL PIPE MOUNTING

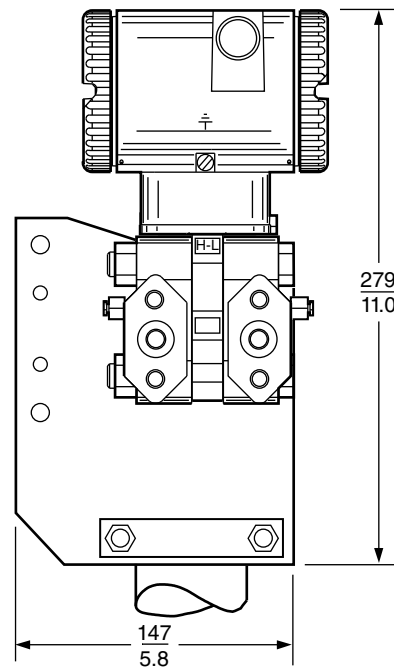

DP Transmitters

Figure 75 - DP Transmitters with Traditional Structure

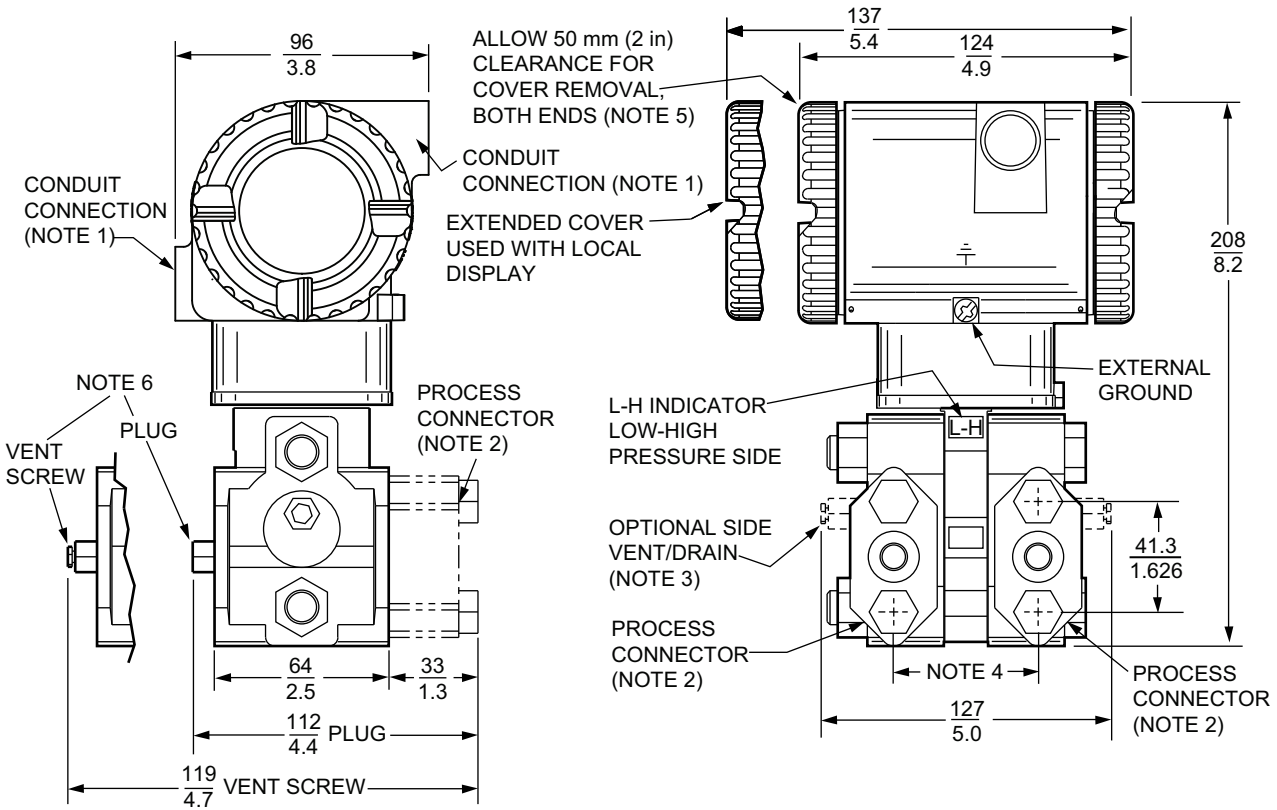

NOTES:

1. CONDUIT CONNECTION 1/2 NPT, BOTH SIDES: PLUG UNUSED CONNECTION WITH SUPPLIED METAL PLUG.
2. PROCESS CONNECTORS MAY BE REMOVED AND TRANSMITTER MOUNTED DIRECTLY ON A MANIFOLD, OR CONNECTIONS MADE DIRECTLY TO PROCESS COVER USING 1/4 NPT INTERNAL THREAD IN PROCESS COVER.
3. PROCESS COVER CAN BE INVERTED MAKING OPTIONAL SIDE VENTS OR SIDE DRAINS.
4. PROCESS CONNECTORS CAN BE INVERTED TO GIVE EITHER 51, 54, OR 57 mm (2.0, 2.125, OR 2.25 in) CENTER-TO-CENTER DISTANCE BETWEEN HIGH AND LOW PRESSURE CONNECTIONS.
5. TOPWORKS CAN BE ROTATED TO ANY POSITION WITHIN ONE TURN COUNTERCLOCKWISE OF THE FULLY TIGHTENED POSITION.
6. PROCESS COVER END PLUGS ARE SUBSTITUTED FOR VENT SCREWS WHEN OPTIONAL SIDE VENTS (NOTE 3) ARE SPECIFIED.

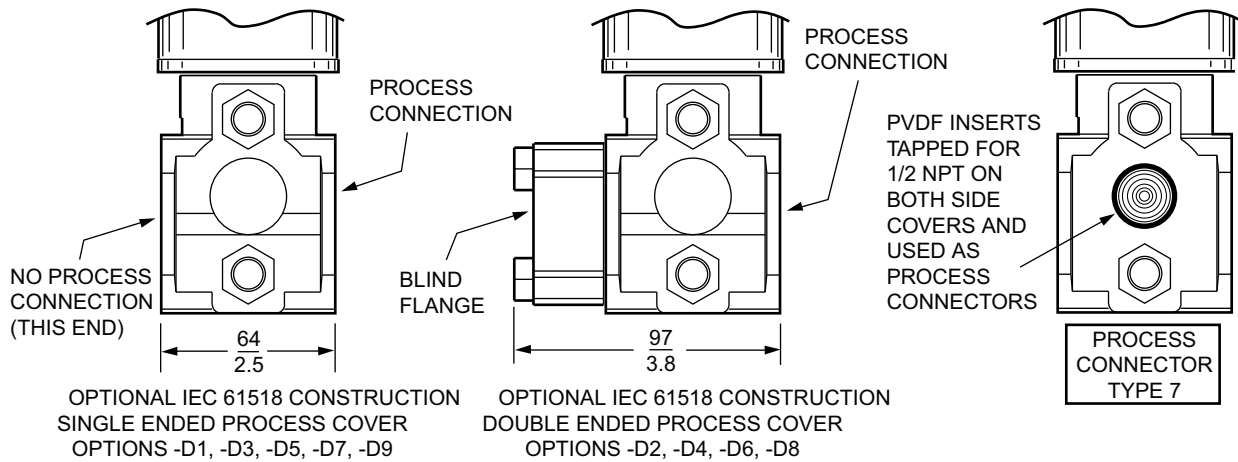
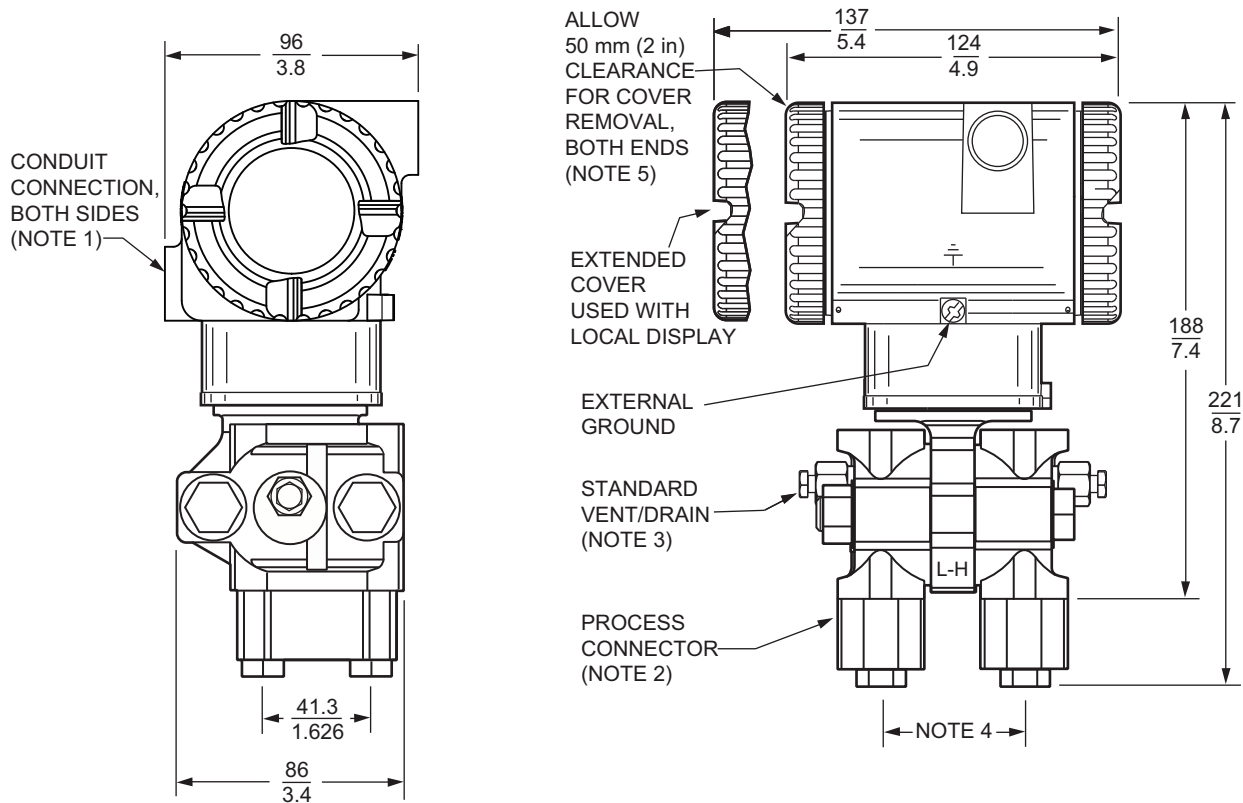

Figure 76 - DP Transmitters with Low Profile 1 (LP1) Structure



NOTES:

1. CONDUIT CONNECTION 1/2 NPT OR M20, BOTH SIDES: PLUG UNUSED CONNECTION WITH SUPPLIED METAL PLUG.
2. PROCESS CONNECTORS MAY BE REMOVED AND TRANSMITTER MOUNTED DIRECTLY ON A MANIFOLD, OR CONNECTIONS MADE DIRECTLY TO PROCESS COVER USING 1/4 NPT INTERNAL THREAD IN PROCESS COVER.
3. THE TRANSMITTER'S LOW PROFILE STRUCTURE LP1 IS SHOWN IN THE VERTICALLY UPRIGHT POSITION. NOTE THE LOCATION OF THE STANDARD VENT/DRAIN SCREW. IN THIS CONFIGURATION, THE TRANSMITTER CAN BE VENTED OR IS SELF-DRAINING. ALSO RECOMMENDED IS A HORIZONTAL INSTALLATION WHERE THE INSTALLED ORIENTATION CAN BE SET TO ALLOW FOR VENTING OR DRAINING.
4. PROCESS CONNECTORS CAN BE INVERTED TO GIVE EITHER 51, 54, OR 57 mm (2.0, 2.125, OR 2.25 in) CENTER-TO-CENTER DISTANCE BETWEEN HIGH AND LOW PRESSURE CONNECTIONS.
5. TOPWORKS CAN BE ROTATED TO ANY POSITION WITHIN ONE TURN COUNTERCLOCKWISE OF THE FULLY TIGHTENED POSITION.

Figure 77 - DP Transmitters with Low Profile 2 (LP2) Structure

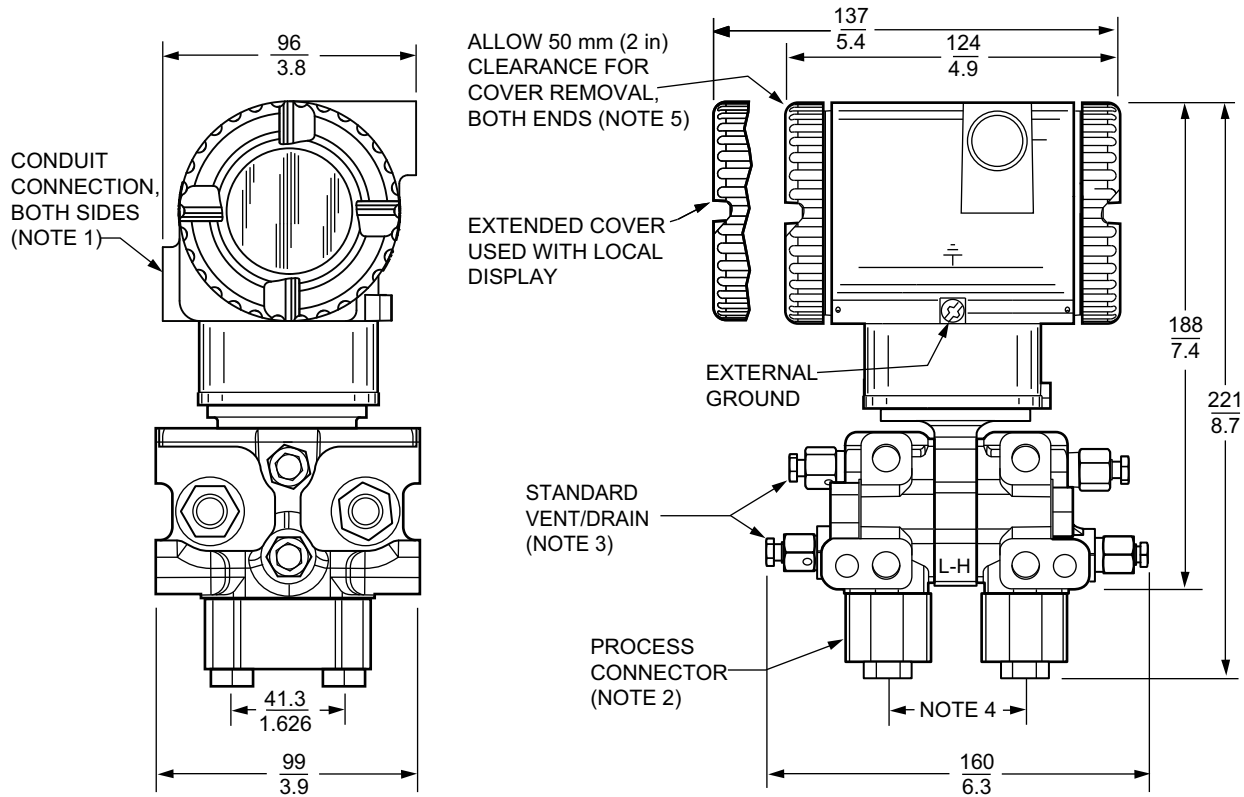

NOTES:

1. CONDUIT CONNECTION 1/2 NPT OR M20, BOTH SIDES: PLUG UNUSED CONNECTION WITH SUPPLIED METAL PLUG.
2. PROCESS CONNECTORS MAY BE REMOVED AND TRANSMITTER MOUNTED DIRECTLY ON A MANIFOLD, OR CONNECTIONS MADE DIRECTLY TO PROCESS COVER USING 1/4 NPT INTERNAL THREAD IN PROCESS COVER.
3. THE TRANSMITTER'S LOW PROFILE STRUCTURE LP2 IS SHOWN IN THE RECOMMENDED VERTICAL UPRIGHT POSITION. NOTE THE STANDARD VENT OR DRAIN SCREWS. HORIZONTAL INSTALLATIONS ARE NOT RECOMMENDED.
4. PROCESS CONNECTORS CAN BE INVERTED TO GIVE EITHER 51, 54, OR 57 mm (2.0, 2.125, OR 2.25 in) CENTER-TO-CENTER DISTANCE BETWEEN HIGH AND LOW PRESSURE CONNECTIONS.
5. TOPWORKS CAN BE ROTATED TO ANY POSITION WITHIN ONE TURN COUNTERCLOCKWISE OF THE FULLY TIGHTENED POSITION.

Figure 78 - DP Transmitters with Traditional or LP2 Structure and Options -M1 and -M2 (Standard Style Mounting Bracket)

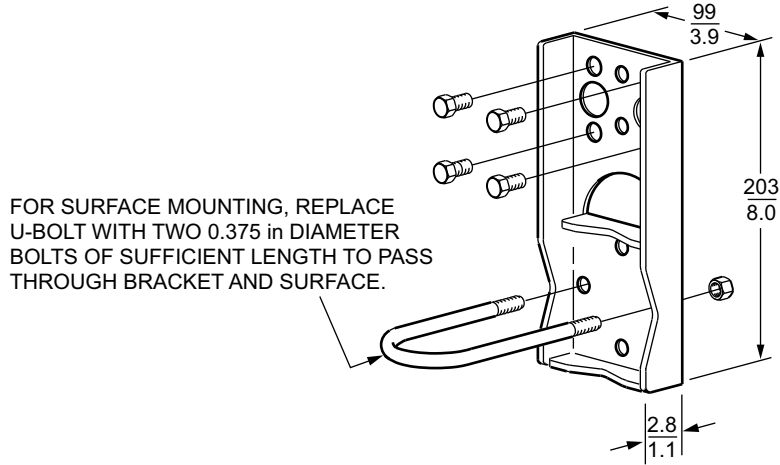

TRANSMITTER WITH TRADITIONAL STRUCTURE

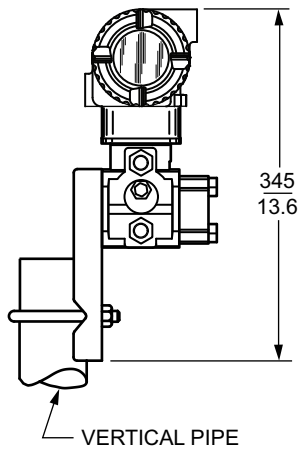

TRANSMITTER WITH LOW PROFILE STRUCTURE LP2

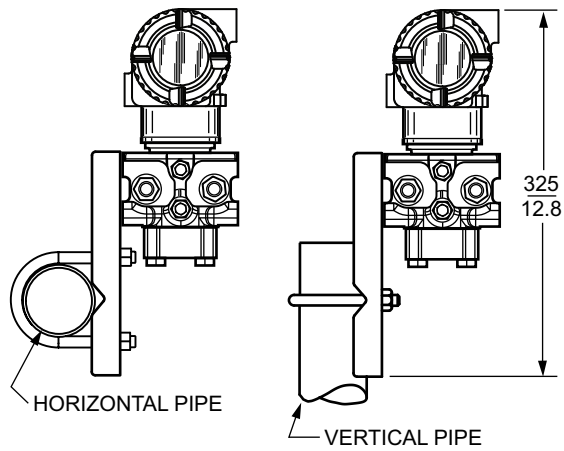
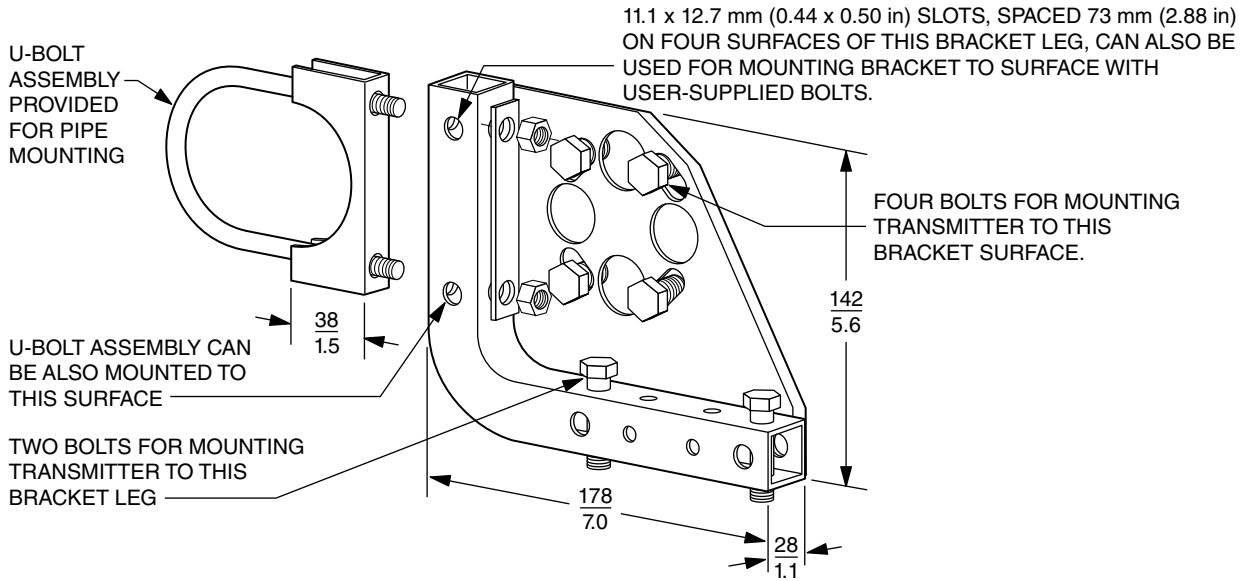
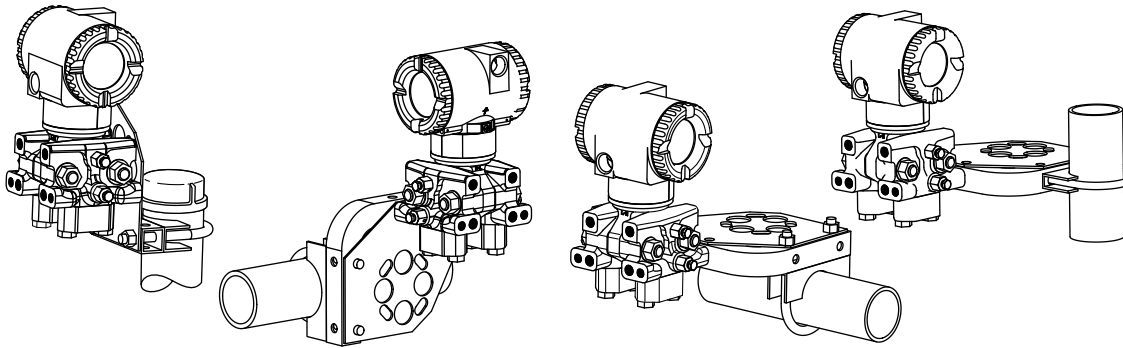

Figure 79 - DP Transmitters with Option -M3 (Universal Style Mounting Bracket Kit)



TYPICAL PIPE MOUNTING WITH LOW PROFILE STRUCTURE LP2



TYPICAL PIPE MOUNTING
LOW PROFILE STRUCTURE LP1

TYPICAL PIPE MOUNTING
WITH TRADITIONAL STRUCTURE

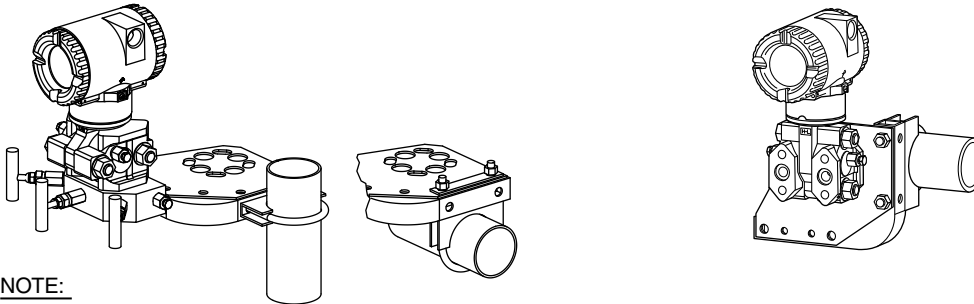

NOTE:

FOR SURFACE MOUNTING CONFIGURATIONS, USE THE U-BOLT MOUNTING HOLES FOR ATTACHING THE BRACKET TO A SURFACE RATHER THAN TO THE U-BOLT ASSEMBLY. SURFACE MOUNTING BOLTS FOR ATTACHING THE BRACKET TO A SURFACE ARE USER SUPPLIED.

Figure 80 - DP Transmitters with LP1 or LP2 Structure Mounted on a Coplanar™ Manifold

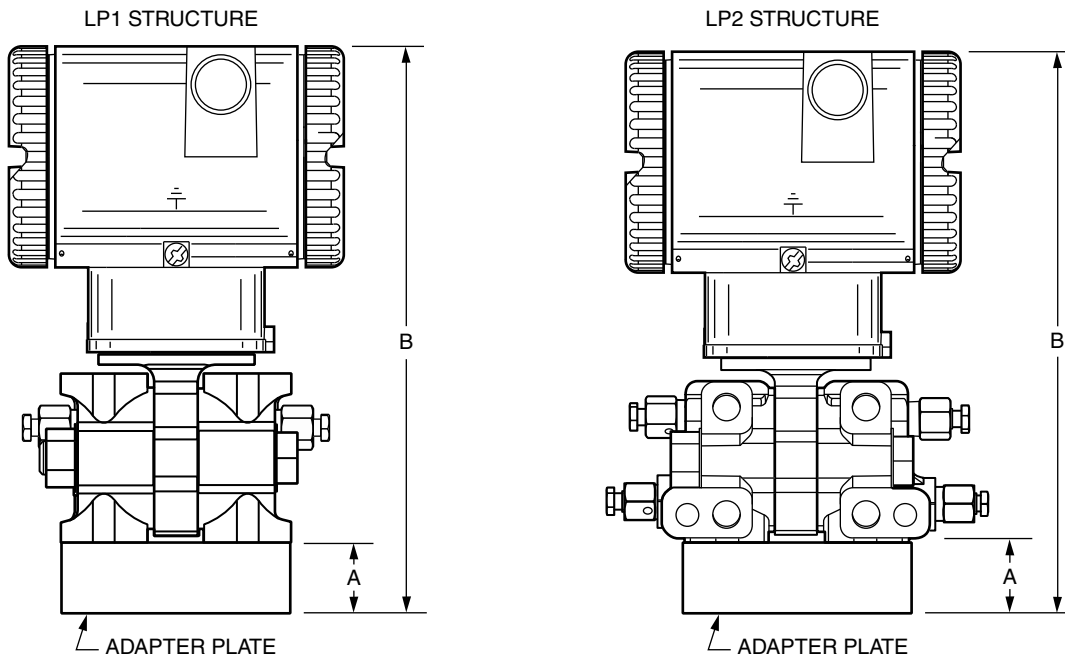

Manifold	Dimension A	Dimension B
MC	11 mm (0.5 in)	199 mm (7.9 in)
MT3	22 mm (0.9 in)	210 mm (8.3 in)

Figure 81 - DP Transmitters with Traditional Structure and Structure Codes -78 and -79 (Filled PVDF Connection)

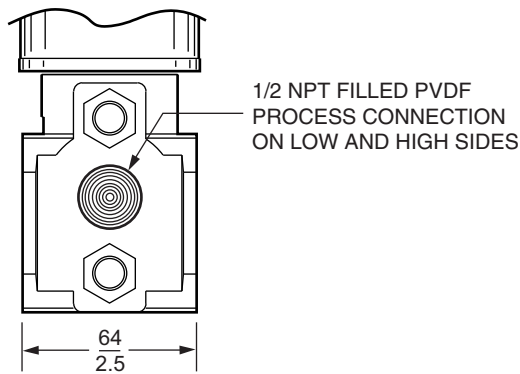
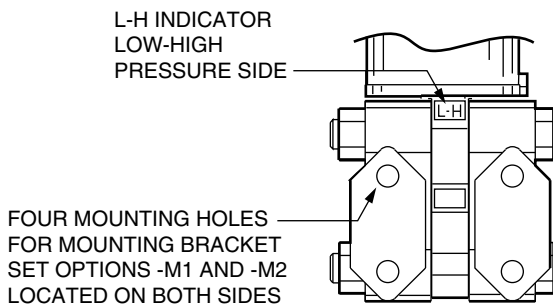

Figure 82 - DP Transmitters with Traditional Structure and Options -D1 to -D9



Parts

Model Codes

These tables list all of the available options, including other protocols, for the Absolute, Gauge, and Differential Pressure Transmitters.

Absolute and Gauge Pressure Transmitters

Table 14 - Absolute and Gauge Pressure Transmitters

Code	Description
Model	
IAP	Absolute Pressure Transmitter
IGP	Gauge Pressure Transmitter
Tier	
05S	Value Performance ⁵⁴
10S	Advanced Performance ⁵⁵ with FoxCal™
50S	Premium Performance ⁵⁶ with FoxCal™
Electronics Versions/Output Signals	
-T	HART and 4 to 20 mA with SIL 2
-F	FOUNDATION Fieldbus H1 Digital Communications ⁵⁷
-V	Low Power Electronics, 1 to 5 Volts ⁵⁸

54. Refer to PSS 2A-1S05 A for accuracy specifications.

55. Refer to PSS 2A-1S10 A for accuracy specifications.

56. Refer to PSS 2A-1S50 A for accuracy specifications.

57. Not available with the Value (05S) transmitter.

58. Available only with the Value (05S) transmitter.

Table 14 - Absolute and Gauge Pressure Transmitters (Continued)

Code	Description
Structure Codes	
Structure — Direct Connect⁵⁹	
20	316L ss Process Sensor; Co-Ni-Cr Diaphragm; Silicone Fill; 1/2 NPT Ext. Conn.; 1/4 NPT Int. Conn. ⁶⁰
21	316L ss Process Sensor; Co-Ni-Cr Diaphragm; Inert Fill; 1/2 NPT Ext. Conn.; 1/4 NPT Int. Conn. ⁶⁰
22	316L ss Process Sensor; 316L ss Diaphragm; Silicone Fill; 1/2 NPT Ext. Conn.; 1/4 NPT Int. Conn.
23	316L ss Process Sensor; 316L ss Diaphragm; Inert Fill; 1/2 NPT Ext. Conn.; 1/4 NPT Int. Conn.
30	316L ss Process Sensor; C276 Diaphragm; Silicone Fill; 1/2 NPT Ext. Conn.; 1/4 NPT Int. Conn.
31	316L ss Process Sensor; C276 Diaphragm; Inert Fill; 1/2 NPT Ext. Conn.; 1/4 NPT Int. Conn.
32	C276 Process Sensor; C276 Diaphragm; Silicone Fill; 1/2 NPT Ext. Conn.; 1/4 NPT Int. Conn.
33	C276 Process Sensor; C276 Diaphragm; Inert Fill; 1/2 NPT Ext. Conn.; 1/4 NPT Int. Conn.
34	316L ss Process Sensor; Co-Ni-Cr Diaphragm; Silicone Fill; 1/2 NPT Internal Conn. Only ^{60 61}
35	316L ss Process Sensor; Co-Ni-Cr Diaphragm; Inert Fill; 1/2 NPT Internal Conn. Only ^{60 61}
36	316L ss Process Sensor; 316L ss Diaphragm; Silicone Fill; 1/2 NPT Internal Conn. Only ^{61 62}
37	316L ss Process Sensor; 316L ss Diaphragm; Inert Fill; 1/2 NPT Internal Conn. Only ^{61 62}
38	316L ss Process Sensor; C276 Diaphragm; Silicone Fill; 1/2 NPT Internal Conn. Only ^{61 62}
39	316L ss Process Sensor; C276 Diaphragm; Inert Fill; 1/2 NPT Internal Conn. Only ^{61 62}
E2	316L ss Process Sensor; 316L ss Diaphragm; Silicone Fill; M20 External Conn. Only ^{61 62}
E3	316L ss Process Sensor; 316L ss Diaphragm; Inert Fill; M20 External Conn. Only ^{61 62}
E4	316L ss Process Sensor; C276 Diaphragm; Silicone Fill; M20 External Conn. Only ^{61 62}
E5	316L ss Process Sensor; C276 Diaphragm; Inert Fill; M20 External Conn. Only ⁶¹
E6	C276 Process Sensor; C276 Diaphragm; Silicone Fill; M20 External Conn. Only ^{61 63}
E7	C276 Process Sensor; C276 Diaphragm; Inert Fill; M20 External Conn. Only ^{61 63}

59. Not available with Electrical Certification codes that end in D or P.

60. Not available with the Value (05S) transmitter.

61. Not available with option codes -V1, -V2, -V3, and -V4.

62. Not available with Electronics Version -V.

63. Not available for 10K PSI (Span Code J).

Table 14 - Absolute and Gauge Pressure Transmitters (Continued)

Code	Description
Structure — Direct Connect Gold-Plated⁶⁴ ⁶⁵	
42	316L ss Process Sensor; Co-Ni-Cr Diaphragm; Silicone Fill; 1/2 NPT Internal Conn. Only ⁶⁶
43	316L ss Process Sensor; Co-Ni-Cr Diaphragm; Inert Fill; 1/2 NPT Internal Conn. Only ⁶⁶
44	316L ss Process Sensor; 316L ss Diaphragm; Silicone Fill; 1/2 NPT Internal Conn. Only ⁶⁶
45	316L ss Process Sensor; 316L ss Diaphragm; Inert Fill; 1/2 NPT Internal Conn. Only ⁶⁶
46	316L ss Process Sensor; C276 Diaphragm; Silicone Fill; 1/2 NPT Internal Conn. Only ⁶⁶
47	316L ss Process Sensor; C276 Diaphragm; Inert Fill; 1/2 NPT Internal Conn. Only ⁶⁶
70	316L ss Process Sensor; Co-Ni-Cr Diaphragm; Silicone Fill; 1/2 NPT Ext. Conn.; 1/4 NPT Int. Conn.
71	316L ss Process Sensor; Co-Ni-Cr Diaphragm; Inert Fill; 1/2 NPT Ext. Conn.; 1/4 NPT Int. Conn.
72	316L ss Process Sensor; 316L ss Diaphragm; Silicone Fill; 1/2 NPT Ext. Conn.; 1/4 NPT Int. Conn.
73	316L ss Process Sensor; 316L ss Diaphragm; Inert Fill; 1/2 NPT Ext. Conn.; 1/4 NPT Int. Conn.
80	316L ss Process Sensor; C276 Diaphragm; Silicone Fill; 1/2 NPT Ext. Conn.; 1/4 NPT Int. Conn.
81	316L ss Process Sensor; C276 Diaphragm; Inert Fill; 1/2 NPT Ext. Conn.; 1/4 NPT Int. Conn.
82	C276 Process Sensor; C276 Diaphragm; Silicone Fill; 1/2 NPT Ext. Conn.; 1/4 NPT Int. Conn.
83	C276 Process Sensor; C276 Diaphragm; Inert Fill; 1/2 NPT Ext. Conn.; 1/4 NPT Int. Conn.
G2	316L ss Process Sensor; 316L ss Diaphragm; Silicone Fill; M20 External Conn. Only ⁶⁶
G3	316L ss Process Sensor; 316L ss Diaphragm; Inert Fill; M20 External Conn. Only ⁶⁶
G4	316L ss Process Sensor; C276 Diaphragm; Silicone Fill; M20 External Conn. Only ⁶⁶
G5	316L ss Process Sensor; C276 Diaphragm; Inert Fill; M20 External Conn. Only ⁶⁶
G6	C276 Process Sensor; C276 Diaphragm; Silicone Fill; M20 External Conn. Only ⁶⁶
G7	C276 Process Sensor; C276 Diaphragm; Inert Fill; M20 External Conn. Only ⁶⁶

64. Not available with the Value (05S) transmitter.

65. Not available with Electrical Certification codes that end in D or P.

66. Not available with option codes -V1, -V2, -V3, and -V4.

Table 14 - Absolute and Gauge Pressure Transmitters (Continued)

Code	Description
Structure — Direct Connect Flameproof	
52	316L ss Process Sensor; 316L ss Diaphragm; Silicone Fill; 1/2 NPT Ext. Conn.; 1/4 NPT Int. Conn.
53	316L ss Process Sensor; 316L ss Diaphragm; Inert Fill; 1/2 NPT Ext. Conn.; 1/4 NPT Int. Conn.
60	316L ss Process Sensor; C276 Diaphragm; Silicone Fill; 1/2 NPT Ext. Conn.; 1/4 NPT Int. Conn.
61	316L ss Process Sensor; C276 Diaphragm; Inert Fill; 1/2 NPT Ext. Conn.; 1/4 NPT Int. Conn.
62	C276 Process Sensor; C276 Diaphragm; Silicone Fill; 1/2 NPT Ext. Conn.; 1/4 NPT Int. Conn.
63	C276 Process Sensor; C276 Diaphragm; Inert Fill; 1/2 NPT Ext. Conn.; 1/4 NPT Int. Conn.
90	316L ss Process Sensor; 316L ss Diaphragm; Silicone Fill; 1/2 NPT Internal Conn. Only ^{67 68}
91	316L ss Process Sensor; 316L ss Diaphragm; Inert Fill; 1/2 NPT Internal Conn. Only ^{67 68}
92	316L ss Process Sensor; C276 Diaphragm; Silicone Fill; 1/2 NPT Internal Conn. Only ^{67 68}
93	316L ss Process Sensor; C276 Diaphragm; Inert Fill; 1/2 NPT Internal Conn. Only ^{67 68}
F2	316L ss Process Sensor; 316L ss Diaphragm; Silicone Fill; M20 External Conn. Only ^{67 68}
F3	316L ss Process Sensor; 316L ss Diaphragm; Inert Fill; M20 External Conn. Only ^{67 68}
F4	316L ss Process Sensor; C276 Diaphragm; Silicone Fill; M20 External Conn. Only ^{67 68}
F5	316L ss Process Sensor; C276 Diaphragm; Inert Fill; M20 External Conn. Only ^{67 68}
F6	C276 Process Sensor; C276 Diaphragm; Silicone Fill; M20 External Conn. Only ^{67 69}
F7	C276 Process Sensor; C276 Diaphragm; Inert Fill; M20 External Conn. Only ^{67 69}

67. Not available with option codes -V1, -V2, -V3, and -V4.

68. Not available with Electronics Version -V.

69. Not available for 10K PSI (Span Code J).

Table 14 - Absolute and Gauge Pressure Transmitters (Continued)

Code	Description
Structure — Biplanar (Vented Low Side Process Cover and Diaphragm)	
B0	316 ss Cover; Co-Ni-Cr Diaphragm; Silicone Fill ⁷⁰
B1	316 ss Cover; Co-Ni-Cr Diaphragm; Inert Fill ⁷⁰
B2	316 ss Cover; 316L ss Diaphragm; Silicone Fill
B3	316 ss Cover; 316L ss Diaphragm; Inert Fill
BG	316 ss Cover; 316 ss Gold-Plated Diaphragm; Silicone Fill ⁷⁰
B4	316 ss Cover; Monel Diaphragm; Silicone Fill ⁷⁰
B5	316 ss Cover; Monel Diaphragm; Inert Fill ⁷⁰
B6	316 ss Cover; C276 Diaphragm; Silicone Fill
B7	316 ss Cover; C276 Diaphragm; Inert Fill
N4	Monel Cover; Monel Diaphragm; Silicone Fill ⁷⁰
N5	Monel Cover; Monel Diaphragm; Inert Fill ⁷⁰
C6	C276 Cover; C276 Diaphragm; Silicone Fill ⁷⁰
C7	C276 Cover; C276 Diaphragm; Inert Fill ⁷⁰
C8	C276 Cover; Tantalum Diaphragm; Silicone Fill ⁷⁰
C9	C276 Cover; Tantalum Diaphragm; Inert Fill ⁷⁰
78	PVDF Insert; Tantalum Diaphragm; Silicone Fill ⁷⁰ ⁷¹
79	PVDF Insert; Tantalum Diaphragm; Inert Fill ⁷⁰ ⁷¹
Structure — LP1 Biplanar (Not Available with Pressure Seals)⁷²	
LL	316 ss Cover; 316L ss Diaphragm; Silicone Fill
LM	316 ss Cover; 316L ss Diaphragm; Inert Fill
LC	316 ss Cover; C276 Diaphragm; Silicone Fill
LD	316 ss Cover; C276 Diaphragm; Inert Fill
CC	C276 Cover; C276 Diaphragm; Silicone Fill ⁷⁰
CD	C276 Cover; C276 Diaphragm; Inert Fill ⁷⁰
Structure — LP2 Biplanar (Not Available with Pressure Seals)⁷²	
L2	316 ss Cover; 316L ss Process Sensor and Diaphragm; Silicone Fill
L3	316 ss Cover; 316L ss Process Sensor and Diaphragm; Inert Fill
L6	316 ss Cover; 316L ss Process Sensor; C276 Diaphragm; Silicone Fill
L7	316 ss Cover; 316L ss Process Sensor; C276 Diaphragm; Inert Fill

70. Not available with the Value (05S) transmitter.

71. Maximum pressure rating is 2.1 MPa (300 psi); temperature limits are derated to -7 and +82°C (+20 and +180°F).

72. Not available with Electronics Version -V.

Table 14 - Absolute and Gauge Pressure Transmitters (Continued)

Code	Description
Structure — Direct Connect, Prepared for Schneider Electric Model Coded Pressure Seals⁷³	
D1	316L ss Process Sensor and Diaphragm; Silicone Fill; Prepared for Direct Connect Seal ⁷⁴
D2	316L ss Process Sensor and Diaphragm; Inert Fill; Prepared for Direct Connect Seal ⁷⁴
S3	316L ss Process Sensor and Diaphragm; Silicone Fill; Prepared for Remote Mount Seal ⁷⁵
S4	316L ss Process Sensor and Diaphragm; Inert Fill; Prepared for Remote Mount Seal ⁷⁵
Structure — Direct Connect, Prepared for Non-Schneider Electric Model Coded Pressure Seals^{73 76}	
SC	316L ss Process Sensor and Diaphragm; Silicone Fill; Prepared for Remote Mount Seal
SD	316L ss Process Sensor and Diaphragm; Inert Fill; Prepared for Remote Mount Seal
Structure — Biplanar, Prepared for Schneider Electric Model Coded Pressure Seals^{77 78}	
P1	316 ss Cover; 316L ss Process Sensor and Diaphragm; Silicone Fill; Prepared for Direct Connect Seal ⁷⁹
P2	316 ss Cover; 316L ss Process Sensor and Diaphragm; Inert Fill; Prepared for Direct Connect Seal ⁷⁹
P3	316 ss Cover; 316L ss Process Sensor and Diaphragm; Silicone Fill; Prepared for Remote Mount Seal ⁷⁵
P4	316 ss Cover; 316L ss Process Sensor and Diaphragm; Inert Fill; Prepared for Remote Mount Seal ⁷⁵
Structure — Biplanar, Prepared for Non-Schneider Electric Model Coded Pressure Seals^{76 78}	
P5	316 ss Cover; 316L ss Process Sensor and Diaphragm; Silicone Fill; Prepared for Remote Mount Seal
P6	316 ss Cover; 316L ss Process Sensor and Diaphragm; Inert Fill; Prepared for Remote Mount Seal
Structure — Direct Connect Flameproof, Prepared for Schneider Electric Model Coded Pressure Seals	
D5	316L ss Process Sensor and Diaphragm; Silicone Fill; Prepared for Direct Connect Seal ⁷⁴
D6	316L ss Process Sensor and Diaphragm; Inert Fill; Prepared for Direct Connect Seal ⁷⁴
S5	316L ss Process Sensor and Diaphragm; Silicone Fill; Prepared for Remote Mount Seal ⁷⁵
S6	316L ss Process Sensor and Diaphragm; Inert Fill; Prepared for Remote Mount Seal ⁷⁵
Structure — Direct Connect Flameproof, Prepared for Non-Schneider Electric Model Coded Pressure Seals⁷⁶	
SH	316L ss Process Sensor and Diaphragm; Silicone Fill; Prepared for Remote Mount Seal
SJ	316L ss Process Sensor and Diaphragm; Inert Fill; Prepared for Remote Mount Seal

73. Not available with Electrical Certification codes that end in D or P.

74. Specify direct connect seal PSFFD, PSFAD, PSISD, or PSTAD.

75. Specify remote mount seal PSFFR, PSFAR, PSFES, PSFPS, PSISR, PSSCR, PSSSR, or PSTAR.

76. These structures are prepared for attachment of pressure seals by others. Do not specify a Schneider Electric seal model code.

77. Not available with optional Biplanar Process Connector (codes -F1 through -F6).

78. Not available with options -X1, -X2, or -X3.

79. Specify biplanar, direct connect seal PSFLT, PSSST, or PSSCT.

Table 14 - Absolute and Gauge Pressure Transmitters (Continued)

Code	Description
Structure — Direct Connect, Prepared for Sanitary or Pulp and Paper Seals^{80 81}	
TA	316L ss Process Sensor; 316L ss Diaphragm; Neobee Fill; 1.5" Tri-Clamp Sanitary Connection
T2	316L ss Process Sensor; 316L ss Diaphragm; Neobee Fill; 2.0" Tri-Clamp Sanitary Connection
T3	316L ss Process Sensor; 316L ss Diaphragm; Neobee Fill; 3.0" Tri-Clamp Sanitary Connection
TB	316L ss Process Sensor; C276 Diaphragm; Neobee Fill; 1.5" Tri-Clamp Sanitary Connection
T4	316L ss Process Sensor; C276 Diaphragm; Neobee Fill; 2.0" Tri-Clamp Sanitary Connection
T5	316L ss Process Sensor; C276 Diaphragm; Neobee Fill; 3.0" Tri-Clamp Sanitary Connection
M1	316L ss Process Sensor; 316L ss Diaphragm; Neobee Fill; Mini Tank Spud Seal, 1.5" Ext.
M6	316L ss Process Sensor; 316L ss Diaphragm; Neobee Fill; Mini Tank Spud Seal, 6" Ext.
M9	316L ss Process Sensor; 316L ss Diaphragm; Neobee Fill; Mini Tank Spud Seal, 9" Ext.
PA	316L ss Process Sensor; 316L ss Diaphragm; Silicone Fill; Sleeve Type 1" (nominal)
PB	316L ss Process Sensor; 316L ss Diaphragm; Silicone Fill; Threaded Type 1" (nominal)
PC	316L ss Process Sensor; 316L ss Diaphragm; Silicone Fill; Sleeve Type 1.5" (nominal)
PD	316L ss Process Sensor; 316L ss Diaphragm; Silicone Fill; Threaded Type 1.5" (nominal)
PE	316L ss Process Sensor; C276 Diaphragm; Silicone Fill; Sleeve Type 1" (nominal)
PF	316L ss Process Sensor; C276 Diaphragm; Silicone Fill; Threaded Type 1" (nominal)
PG	316L ss Process Sensor; C276 Diaphragm; Silicone Fill; Sleeve Type 1.5" (nominal)
PH	316L ss Process Sensor; C276 Diaphragm; Silicone Fill; Threaded Type 1.5" (nominal)
PJ	316L ss Process Sensor; C276 Diaphragm; Silicone Fill; Threaded Type 1.5" (fits Ametek spud)
Structure — Direct Connect, High Pressure (Gauge Pressure Only)⁸²	
24	15-5 ss Process Sensor and Diaphragm; 1/4 NPT Internal Connection ⁸³
26	Inconel X-750 Process Sensor and Diaphragm; 1/4 NPT Internal Connection ⁸³
28	13-8 Moly ss Process Sensor and Diaphragm; Autoclave F-250-C Connection ⁸⁴

80. Not available with Electrical Certification codes that end in D or P.

81. Available with Span Limit codes C and D only.

82. Available only with the Value (05S) transmitter.

83. Available with Span Limit code G only.

84. Available with Span Limit code H only.

Table 14 - Absolute and Gauge Pressure Transmitters (Continued)

Code	Description	
Span Limits		
Code	Transmitters with Direct Connect Structures	Transmitters with Biplanar Structures
A ⁸⁵	n/a	With -T or -F Electronics: n/a With -V Electronics: 0.12 and 7.5 kPa (0.5 and 30 inH ₂ O) ⁸⁶
B	n/a	With -T or -F Electronics: 0.12 and 50 kPa (0.5 and 200 inH ₂ O) With -V Electronics: 0.87 and 50 kPa (3.5 and 200 inH ₂ O)
C	With -T or -F Electronics: n/a With -V Electronics: 6.9 and 207 kPa (1 and 30 psi)	With -T or -F Electronics: 0.62 and 250 kPa (2.49 and 1000 inH ₂ O) With -V Electronics: 6.9 and 207 kPa (1 and 30 psi)
D	With -T or -F Electronics: 3.4 and 1380 kPa (0.5 and 200 psi) With -V Electronics: 69 and 2070 kPa (10 and 300 psi)	With -T or -F Electronics: 26 and 2070 kPa (3.75 and 300 psi) ^{87 88} With -V Electronics: 69 and 2070 kPa (10 and 300 psi) ^{87 88}
E	With -T or -F Electronics: 0.034 and 13.8 MPa (5 and 2000 psi) With -V Electronics: 0.69 and 20.7 MPa (100 and 3000 psi)	With -T or -F Electronics: 0.26 and 20.7 MPa (37.5 and 3000 psi) ^{87 88} With -V Electronics: 0.69 and 20.7 MPa (100 and 3000 psi) ^{87 88}
F	With -T or -F Electronics: 0.52 and 41.4 MPa (75 and 6000 psi) ⁸⁶ With -V Electronics: 13.8 and 41.4 MPa (2000 and 6000 psi) ⁸⁶	With -T or -F Electronics: 1.1 and 34.5 MPa (165 and 5000 psi) ^{86 87 88} With -V Electronics: 1.38 and 34.5 MPa (200 and 5000 psi) ^{86 87 88}
J ⁸⁵	With -T Electronics: 6.9 and 69 MPag (1000 and 10000 psig) ^{86 89} With -V Electronics: 6.9 and 69 MPag (1000 and 10000 psig) ^{86 89}	n/a
G ⁸⁵	With -T Electronics: 34.5 and 104 MPag (5000 and 15000 psig) ^{86 90} With -V Electronics: 34.5 and 104 MPag (5000 and 15000 psig) ^{86 90}	n/a
H ⁸⁵	With -T Electronics: 69 and 207 MPag (10000 and 30000 psig) ^{86 91} With -V Electronics: 69 and 207 MPag (10000 and 30000 psig) ^{86 91}	n/a
Conduit Connection and Housing Material		
1	1/2 NPT Conduit Connection, Both Sides, Aluminum Housing	
3	1/2 NPT Conduit Connection, Both Sides, 316 ss Housing	
5	M20 Conduit Connection, Both Sides, Aluminum Housing	
6	M20 Conduit Connection, Both Sides, 316 ss Housing	

85. Available only with the Value (05S) transmitter.

86. Available for gauge pressure transmitters only.

87. Span limit, maximum working pressure, maximum overrange pressure, and maximum static pressure (d/p) are derated for optional IEC 61518 Construction and optional Bolting except for codes -D3, -D7, and -B2. Option -D1 is derated to 2320 psi. Options -D5 and -B1 are derated to 2175 psi. Options -D2, -D4, -D6, and -D8 are derated to 1500 psi. Option -B3 is derated to 2900 psi.

88. Not available with Structure codes 78 and 79 (PVDF process covers).

89. Available for Model IGP05S only and structure codes 22, 23, 30, 31, 32, 33, 52, 53, 60, 61, 62, and 63.

90. Available with Structure codes 24 and 26 only.

91. Available with Structure code 28 only.

Table 14 - Absolute and Gauge Pressure Transmitters (Continued)

Code	Description
Electrical Certifications	
AA	ATEX intrinsically safe, Ex ia IIC ⁹²
AD	ATEX flameproof, Ex d IIC ⁹³
AM	ATEX multiple certifications (includes ATEX Codes AA and AN) ⁹²
AN	ATEX protection type n, Ex ic IIC, or Ex nA ⁹²
AP	ATEX multiple certifications (includes ATEX Codes AA, AD and AN) ^{92 93}
BA	INMETRO intrinsically safe, Ex ia IIC ⁹²
BD	INMETRO flameproof, Ex d IIC ⁹³
BP	INMETRO multiple certifications (includes INMETRO Codes BA and BD) ^{92 93}
CA	CSA intrinsically safe, Zone certified Ex ia
CD	CSA zone certified flameproof Ex d IIC; also explosion proof, dust ignition-proof ⁹³
CM	CSA multiple certifications (includes CSA Codes CA and CN)
CN	CSA non-incendive, Zone certified Ex nA IIC
CP	CSA multiple certifications (includes CSA Codes CA, CD and CN) ⁹³
DA	Multi-marked ATEX and IECEx intrinsically safe, Ex ia IIC ⁹²
DD	Multi-marked ATEX and IECEx flameproof, Ex d IIC ⁹³
DM	Multi-marked ATEX and IECEx multiple certifications, ia, ic ⁹²
DN	Multi-marked ATEX and IECEx protection type n, Ex ic IIC ⁹²
DP	Multi-marked ATEX and IECEx multiple certifications, ia, ic, and d ^{92 93}
EA	IECEX intrinsically safe, Ex ia IIC ⁹²
ED	IECEX flameproof, Ex d IIC ⁹³
EM	IECEX multiple certifications, ia, ic, nA ⁹²
EN	IECEX protection type n, Ex ic IIC, or Ex nA ⁹²
EP	IECEX multiple certifications, ia, ic, nA, and d ^{92 93}
FA	FM Classes I, II and III Division 1 intrinsically safe, AEx ia IIC
FD	FM Classes I, II and III Division 1 explosion proof, dust-ignition proof, Zone approved AEx d IIC ⁹³
FM	FM multiple certifications (includes FM Codes FA or FN)
FN	Classes I, II and III FM Division 2 non-incendive, Zone approved AEx nA IIC
FP	FM multiple certifications (includes FM Codes FA, FD or FN) ⁹³
KD	KOSHA Ex d ⁹⁴
RA	EAC intrinsically safe, Ex ia ⁹²
RD	EAC flameproof, Ex d ^{92 93}
RN	EAC protection type n, Ex ic IIC or Ex nA ⁹²
ZZ	No certification

92. Not available with Electronics Version -V.

93. Available with all biplanar structures and only the following Direct Connect Structure codes: 52, 53, 60, 61, 62, 63, 90, 91, 92, 93, F2, F3, F4, F5, F6, F7, D5, D6, S5, S6, SH, SJ, 24, 26, and 28.

94. Available only with Structure codes 52, 53, 60, 61, B2, B3, B6, B7, P1, P2, P3, P4, P5, P6, D5, D6, S5, S6, SH, SJ, 24, 26, and 28.

Table 14 - Absolute and Gauge Pressure Transmitters (Continued)

Code	Description
Optional Mounting Bracket Sets	
-M1	Painted Steel Bracket, Plated Steel Bolts, 1/2 NPT, Direct Connect Only ^{95 96 97}
-M2	Stainless Steel Bracket, Stainless Steel Bolts, 1/2 NPT, Direct Connect Only ^{95 96 97}
-M3	Universal Stainless Steel Mounting Bracket Set, Stainless Steel Hardware, Biplanar Only
-M5	Painted Steel Bracket, Plated Steel Bolts, M20, Direct Connect Only ^{95 96 98}
-M6	Stainless Steel Bracket, Stainless Steel Bolts, M20, Direct Connect Only ^{95 96 98}
-M7	Stainless Steel Bracket for Flameproof Direct Connect Sensor Structures ⁹⁹
-M8	Painted Steel Bracket for Flameproof Direct Connect Sensor Structures ⁹⁹
-M9	Painted Steel Bracket, Plated Steel Bolts, Biplanar Only
-M0	Stainless Steel Bracket, Stainless Steel Bolts, Biplanar Only
Optional Vent Screw and Block and Bleed Valve	
-V1	316 ss Vent Screw in Process Connection ^{95 100 101}
-V2	Block and Bleed Valve, Carbon Steel ^{95 100 102}
-V3	Block and Bleed Valve, 316 ss ^{95 100 102}
-V4	Block and Bleed Valve, 316 ss w/ Monel Trim, NACE Approved ^{95 100 102}
-V5	Vent Screw in Side of Process Cover ^{103 104 105}
-V6	Omit Vent Screw ¹⁰⁶
Optional Biplanar Process Connector Type (same material as Process Cover)^{103 107}	
-F1	1/4 NPT ¹⁰⁸
-F2	1/2 NPT
-F3	RC 1/4 ¹⁰⁸
-F4	RC 1/2
-F6	1/2 Schedule 80 Weld Neck ¹⁰⁸
Options for Digital Indicator with Pushbuttons	
-L1	Digital Display, Pushbuttons and Window Cover ¹⁰⁹
-L2	Substitute Solid Cover over Digital Display ¹¹⁰

95. Not available with biplanar structures.

96. Not available with Electrical Certification codes that end in D or P.

97. Available with Conduit Connection and Housing Material codes 1 and 3 only.

98. Available with Conduit Connection and Housing Material codes 5 and 6 only.

99. Available only with flameproof Direct Connect Structure codes, excluding D5 and D6.

100. Not available with option -G.

101. Available only with 1/2 NPT 316L ss Structure codes 20, 21, 22, 23, 30, 31, 52, 53, 60, 61, 70, 71, 72, 73, 80, and 81.

102. Available only with structures that have 1/2 NPT external connections.

103. Available with biplanar structures only.

104. Not available with Structure codes LL, LM, LC, LD, CC, CD, L2, L3, L6, or L7. A vent screw in the side of the process cover is standard with these structures.

105. Not available with optional IEC 61518 Construction codes -D1 through -D9.

106. Available only for transmitters with biplanar LP1 or LP2 structures.

107. Not available with Structure codes 78 and 79 (PVDF process covers).

108. Not available with biplanar C276 structures.

109. Not available with Electronics Version -V.

110. Available only with Electronics Version -V.

Table 14 - Absolute and Gauge Pressure Transmitters (Continued)

Code	Description
Optional IEC 61518 Construction^{111 112}	
-D1	Single-Ended Process Cover with B7 Steel Bolt; No Connector Screw; MWP=2320 psi ¹¹³
-D2	Double-Ended Process Cover ¹¹⁴ with B7 Steel Bolt; Size M10 Steel Connector Screw; MWP=1500 psi ^{115 116 117}
-D3	Single-Ended Process Cover with B7 Steel Bolt; No Connector Screw; MWP=3626 psi ¹¹³
-D4	Double-Ended Process Cover ¹¹⁴ with B7 Steel Bolt; Size 7/16 Steel Connector Screw; MWP=1500 psi ^{115 116 117}
-D5	Single-Ended Process Cover with 316 ss Bolt; No Connector Screw; MWP=2175 psi ¹¹³
-D6	Double-Ended Process Cover ¹¹⁴ with 316 ss Bolt; Size 7/16 316 ss Connector Screw; MWP=1500 psi ^{115 116 117}
-D7	Single-Ended Process Cover with 17-4 PH Bolt; No Connector Screw; MWP=3626 psi ¹¹³
-D8	Double-Ended Process Cover ¹¹⁴ with 17-4 PH Bolt; Size 7/16 17-4 PH Connector Screw; MWP=1500 psi ^{115 116 117}
-D9	Single-Ended Process Cover with 17-4 PH Bolt; No Connector Screw; MWP=5800 psi ¹¹³
Optional Cleaning and Preparation¹¹⁸	
-X1	Unit Degreased – for Silicone Fill Sensors Only ¹¹⁹
-X2	Cleaned and Prepared for Oxygen Service – for Inert Fill Sensors Only ^{120 121}
-X3	Cleaned and Prepared for Chlorine Service ^{120 122}
Optional Bolting (Process Covers and Process Connectors)^{111 123 124 125}	
-B1	316 ss Bolts and Nuts (high corrosion protection; MWP derated to 2175 psi) ¹²⁶
-B2	17-4 PH ss Bolts and Nuts (bright acid tin coated corrosion protection with no pressure derating)
-B3	B7M Bolts and 2HM Nuts (conforms to NACE MR0175/MR0103, Class II; MWP derated to 2900 psi) ¹²⁶
Optional Conduit Thread Adapters^{127 128}	
-A1	Hawke-Type 1/2 NPT Brass Cable Gland
-A3	M20 Connector
Optional Custom Factory Configuration	
-C1	Custom Factory Calibration (Calibration and Unit Tags Required) ¹²⁹
-C2	Custom Factory Configuration (requires Configuration Form to be filled out)

111. Span limit, maximum working pressure, maximum overrange pressure, and maximum static pressure (d/p) are derated for optional IEC 61518 Construction and optional Bolting except for codes -D3, -D7, and -B2. Option -D1 is derated to 2320 psi. Options -D5 and -B1 are derated to 2175 psi. Options -D2, -D4, -D6, and -D8 are derated to 1500 psi. Option -B3 is derated to 2900 psi.

112. Not available with optional Biplanar Process Connector (codes -F1 through -F6).

113. Available with Biplanar Structure codes B0, B1, B2, B3, BG, B4, B5, B6, B7, LL, LM, LC, and LD.

114. Blind connector supplied.

115. Temperature limits are derated to -10 and +80°C (14 and 176°F) for optional IEC 61518 Construction codes -D2, -D4, -D6, and -D8 only.

116. Available only with Structure codes B0, B1, B2, B3, BG, B4, B5, B6, and B7.

117. Not available with optional Mounting Bracket Sets -M3, -M9, and -M0.

118. Not available with Span codes G and H.

119. Available only with structures that have silicone fill and are not prepared for seals.

120. Available only with structures that have inert fill (excluding Structure code 79) and are not prepared for seals.

121. After units are cleaned and reassembled for oxygen service, they are not rechecked for accuracy. This may affect performance for DP and biplanar GP transmitters.

122. For -X3, standard bolting is replaced with 17-4 ph ss bolts and nuts. Therefore, Bolting codes -B1, -B2, and -B3 are not available with -X3.

123. Not available with Structure codes 78 and 79 (PVDF process covers).

124. Not available with optional IEC 61518 Construction codes -D1 through -D9.

125. Available with biplanar structures only.

126. See *Maximum Static, Overrange, and Proof Pressure Ratings, page 14* for pressure deratings when certain IEC 61518 options and Bolting Options -B1 or -B3 are specified.

127. Not available with Electrical Certification codes that end in D or P.

128. Available with Conduit Connection and Housing Material codes 1 and 3 only.

129. Not available as a selection for the Value (05S) transmitter because it is standard for these models.

Table 14 - Absolute and Gauge Pressure Transmitters (Continued)

Code	Description
Optional Electronics Housing Features	
-Z1	External Zero Adjustment ^{130 131}
-Z2	Custody Transfer Lock and Seal ¹³²
-Z3	External Zero Adjustment and Custody Transfer Lock/Seal ^{130 131 132}
Optional Ermeto Connectors	
-E3	316 ss for Connecting 6 mm Tubing to 1/4 NPT Process Connector ¹³³
-E4	316 ss for Connecting 12 mm Tubing to 1/2 NPT Process Connector ¹³⁴
Optional Manifold Configurations	
-H1	Manifold Mounted to Transmitter and Pressure Tested (1.5 times transmitter range or 1.5 times manifold rating, whichever is less)
-H2	Manifold Mounted to Transmitter and Pressure Tested (Certificate)
Optional SIL 2 Selections¹³⁵	
-S1	Yellow Cover for SIL2 on Electronics/Indicator Side of Housing
-S2	Red Cover for SIL2 on Electronics/Indicator Side of Housing
Miscellaneous Optional Selections	
-F	Autoclave F-250-C (GP transmitters only) ¹³⁶
-G	G 1/2 B Manometer Process Connection ^{136 137}
-G1	Metal O-Ring for Pressure Seals in Vacuum Service ¹³⁸
-H	1/2 NPT External Thread (GP transmitters only) ¹³⁶
-J	Low Temperature Operative Limit -50°C (-58°F) ^{130 139 140 141}
-K2	FoxDoc DVD-ROM (instead of "Getting Started" Guide)
-R	R 1/2 Process Connection (1/2 NPT to R 1/2 Adapter) ¹⁴²
-T	Supplemental Customer Tag (Stainless Steel Tag Wired onto Transmitter)

130. Not available with Electronics Version -V.

131. Not available for structures with sanitary or pulp and paper seals.

132. For flameproof models, the -Z2 and -Z3 options provide the seals in addition to the cover locks that are already included in the standard offering for these models.

133. Available only with Biplanar Structure codes B0, B1, B2, B3, BG, B4, B5, B6, and B7, and Optional Biplanar Process Connector Type code -F1.

134. Available only with Biplanar Structure codes B0, B1, B2, B3, BG, B4, B5, B6, and B7, and Optional Biplanar Process Connector Type code -F2.

135. Available only with Electronics Version -T.

136. Available with Structure codes 24 and 26 only.

137. Available with non-gold-plated 316L ss direct connect structures with 1/2 NPT external connections.

138. Available only with Structure codes P1, P2, P3, P4, P5, and P6.

139. Not available with Structure codes 78 and 79 (PVDF process covers).

140. Not available with Optional IEC 61518 Construction codes -D2, -D4, -D6, and -D8.

141. Not available with Direct Connect Structure codes 21, 23, 31, 33, 35, 37, 39, E3, E5, E7, 43, 45, 47, 71, 73, 81, 83, G3, G5, G7, 53, 61, 63, 91, 93, F3, F5, F7; Biplanar Structure codes B1, B3, B5, B7, N5, C7, C9, 78, 79, LM, LD, CD, L3, L7, D2, S4, SD, P2, P4, P6, D6, S6, SJ; and all Sanitary/Pulp and Paper structures.

142. Available with 316L ss direct connect structures with 1/2 NPT external connections.

Differential Pressure Transmitters

Table 15 - Differential Pressure Transmitters

Code	Description
Model	
IDP	Differential Pressure Transmitter
Tier	
05S	Value Performance ¹⁴³
10S	Advanced Performance ¹⁴⁴ with FoxCal™
50S	Premium Performance ¹⁴⁵ with FoxCal™
Electronics Versions/Output Signals	
-T	HART and 4 to 20 mA with SIL 2
-F	FOUNDATION Fieldbus H1 Digital Communications ¹⁴⁶
-V	Low Power Electronics, 1 to 5 Volts ¹⁴⁷
Structure Codes	
Structure — Traditional¹⁴⁸	
20	316 ss Cover; Co-Ni-Cr Diaphragm; Silicone Fill; Max Static Pressure=25 MPa (3626 psi) ¹⁴⁶
21	316 ss Cover; Co-Ni-Cr Diaphragm; Inert Fill; Max Static Pressure=25 MPa (3626 psi) ¹⁴⁶
22	316 ss Cover; 316L ss Diaphragm; Silicone Fill; Max Static Pressure=25 MPa (3626 psi)
23	316 ss Cover; 316L ss Diaphragm; Inert Fill; Max Static Pressure=25 MPa (3626 psi)
24	316 ss Cover; Monel Diaphragm; Silicone Fill; Max Static Pressure=25 MPa (3626 psi) ¹⁴⁶
25	316 ss Cover; Monel Diaphragm; Inert Fill; Max Static Pressure=25 MPa (3626 psi) ¹⁴⁶
26	316 ss Cover; C276 Diaphragm; Silicone Fill; Max Static Pressure=25 MPa (3626 psi)
27	316 ss Cover; C276 Diaphragm; Inert Fill; Max Static Pressure=25 MPa (3626 psi)
34	Monel Cover; Monel Diaphragm; Silicone Fill; Max Static Pressure=25 MPa (3626 psi) ¹⁴⁶
35	Monel Cover; Monel Diaphragm; Inert Fill; Max Static Pressure=25 MPa (3626 psi) ¹⁴⁶
46	C276 Cover; C276 Diaphragm; Silicone Fill; Max Static Pressure=25 MPa (3626 psi) ¹⁴⁶
47	C276 Cover; C276 Diaphragm; Inert Fill; Max Static Pressure=25 MPa (3626 psi) ¹⁴⁶
48	C276 Cover; Tantalum Diaphragm; Silicone Fill; Max Static Pressure=25 MPa (3626 psi) ¹⁴⁶
49	C276 Cover; Tantalum Diaphragm; Inert Fill; Max Static Pressure=25 MPa (3626 psi) ¹⁴⁶
78	PVDF Insert; Tantalum Diaphragm; Silicone Fill; Max Static Pressure=2.07 MPa (300 psi) ^{146 149}
79	PVDF Insert; Tantalum Diaphragm; Inert Fill; Max Static Pressure=2.07 MPa (300 psi) ^{146 149}

143. Refer to PSS 2A-1S05 A for accuracy specifications.

144. Refer to PSS 2A-1S10 A for accuracy specifications.

145. Refer to PSS 2A-1S50 A for accuracy specifications.

146. Not available with the Value (05S) transmitter.

147. Available only with the Value (05S) transmitter.

148. Maximum static pressure can be derated by optional selections.

149. Maximum static pressure rating is 2.1 MPa (300 psi); temperature limits are -7 and +82°C (+20 and +180°F).

Table 15 - Differential Pressure Transmitters (Continued)

Code	Description
Structure — LP1 Direct Mount (Not Available with Pressure Seals); Maximum Static Pressure=25 MPa (3626 psi)¹⁵⁰	
LL	316 ss Cover; 316L ss Diaphragm; Silicone Fill
LM	316 ss Cover; 316L ss Diaphragm; Inert Fill
LC	316 ss Cover; C276 Diaphragm; Silicone Fill
LD	316 ss Cover; C276 Diaphragm; Inert Fill
CC	C276 Cover; C276 Diaphragm; Silicone Fill ¹⁵¹
CD	C276 Cover; C276 Diaphragm; Inert Fill ¹⁵¹
Structure — LP2 Bracket Mount or Direct Mount (Not Available with Pressure Seals); Maximum Static Pressure=25 MPa (3626 psi)¹⁵⁰	
52	316 ss Cover; 316L ss Diaphragm; Silicone Fill
53	316 ss Cover; 316L ss Diaphragm; Inert Fill
56	316 ss Cover; C276 Diaphragm; Silicone Fill
57	316 ss Cover; C276 Diaphragm; Inert Fill
Structure — Prepared for Schneider Electric Model Coded Pressure Seals (Static Pressure Rating Limited by Seal)^{152 153}	
S1	316 ss Cover; 316L ss Diaphragm; Silicone Fill; Remote Mount Seals, Both Sides ¹⁵⁴
S2	316 ss Cover; 316L ss Diaphragm; Inert Fill; Remote Mount Seals, Both Sides ¹⁵⁴
S3	316 ss, 1/2 NPT Cover; 316L ss Diaphragm; Silicone Fill; Remote Mount Seal, High Side ¹⁵⁴
S4	316 ss, 1/2 NPT Cover; 316L ss Diaphragm; Inert Fill; Remote Mount Seal, High Side ¹⁵⁴
S5	316 ss, 1/2 NPT Cover; 316L ss Diaphragm; Silicone Fill; Remote Mount Seal, Low Side ¹⁵⁴
S6	316 ss, 1/2 NPT Cover; 316L ss Diaphragm; Inert Fill; Remote Mount Seal, Low Side ¹⁵⁴
F1	316 ss, 1/2 NPT Cover; 316L ss Diaphragm; Silicone Fill; Direct Connect Seal, High Side
F2	316 ss, 1/2 NPT Cover; 316L ss Diaphragm; Inert Fill; Direct Connect Seal, High Side
F3	316 ss Cover; 316L ss Diaphragm; Silicone Fill; Direct Connect Seal, High Side and Remote Mount Seal, Low Side
F4	316 ss Cover; 316L ss Diaphragm; Inert Fill; Direct Connect Seal, High Side and Remote Mount Seal, Low Side
Structure — Prepared for Non-Schneider Electric Model Coded Pressure Seals (Static Pressure Rating Limited by Seal)¹⁵²	
SA	316 ss Cover; 316L ss Diaphragm; Silicone Fill; Remote Mount Seals, Both Sides
SB	316 ss Cover; 316L ss Diaphragm; Inert Fill; Remote Mount Seals, Both Sides
SC	316 ss, 1/2 NPT Cover; 316L ss Diaphragm; Silicone Fill; Remote Mount Seal, High Side
SD	316 ss, 1/2 NPT Cover; 316L ss Diaphragm; Inert Fill; Remote Mount Seal, High Side
SE	316 ss, 1/2 NPT Cover; 316L ss Diaphragm; Silicone Fill; Remote Mount Seal, Low Side
SF	316 ss, 1/2 NPT Cover; 316L ss Diaphragm; Inert Fill; Remote Mount Seal, Low Side

150. Maximum static pressure can be derated by optional selections.

151. Not available with the Value (05S) transmitter.

152. Not available with options -X1, -X2, or -X3.

153. Both transmitter and pressure seal model numbers are required. See PSS 2A-1Z11 B for pressure seal model codes.

154. Remote seal models that may be specified are PSFPS, PSFES, PSFAR, PSTAR, PSISR, PSSCR, and PSSSR.

Table 15 - Differential Pressure Transmitters (Continued)

Code	Description
Span Limits	
A ¹⁵⁵	With -T or -F Electronics: n/a With -V Electronics: 0.12 and 7.5 kPa; 0.5 and 30 inH ₂ O; 1.2 and 75 mbar
B	With -T or -F Electronics: 0.12 and 50 kPa; 0.5 and 200 inH ₂ O; 1.2 and 500 mbar With -V Electronics: 0.87 and 50 kPa; 3.5 and 200 inH ₂ O; 8.7 and 500 mbar
C	With -T or -F Electronics: 0.62 and 250 kPa; 2.5 and 1000 inH ₂ O; 6.2 and 2500 mbar With -V Electronics: 7 and 210 kPa; 28 and 840 inH ₂ O; 70 and 2100 mbar
D	With -T or -F Electronics: 0.026 and 2.07 MPa; 3.75 and 300 psi; 0.26 and 20.7 bar With -V Electronics: 0.069 and 2.07 MPa; 10 and 300 psi; 0.69 and 20.7 bar
E ¹⁵⁶	With -T or -F Electronics: 0.26 and 20.7 MPa; 37.5 and 3000 psi; 2.6 and 207 bar With -V Electronics: 0.69 and 20.7 MPa; 100 and 3000 psi; 6.9 and 207 bar
Process Connector Type (Same Material as the Process Cover)	
0	None
1	1/4 NPT ^{156 157 158}
2	1/2 NPT ^{156 157}
3	RC 1/4 ^{156 157 158}
4	RC 1/2 ^{156 157}
6	1/2 Schedule 80 Weld Neck ^{156 157 158}
7	None; PVDF insert tapped for 1/2 NPT process inlet located on side of process cover ¹⁵⁹
Conduit Connection and Housing Material	
1	1/2 NPT Conduit Connection, Both Sides, Aluminum Housing
3	1/2 NPT Conduit Connection, Both Sides, 316 ss Housing
5	M20 Conduit Connection, Both Sides, Aluminum Housing
6	M20 Conduit Connection, Both Sides, 316 ss Housing
Electrical Certifications	
AA	ATEX intrinsically safe, Ex ia IIC ¹⁶⁰
AD	ATEX flameproof, Ex d IIC
AM	ATEX multiple certifications (includes ATEX Codes AA and AN) ¹⁶⁰
AN	ATEX protection type n, Ex ic IIC, or Ex nA ¹⁶⁰
AP	ATEX multiple certifications (includes ATEX Codes AA, AD and AN) ¹⁶⁰
BA	INMETRO intrinsically safe, Ex ia IIC ¹⁶⁰
BD	INMETRO flameproof, Ex d IIC
BP	INMETRO multiple certifications (includes INMETRO Codes BA and BD) ¹⁶⁰

155. Span limit code A is not available with pressure seals, except for sanitary spud seal models PSSSR-*4 and PSSST-*4.

156. Not available with Structure codes 78 and 79 (PVDF process covers).

157. Not available with structures that have seals on both sides.

158. Not available with structures that have C276 process covers.

159. Available only with Structure codes 78 and 79 (PVDF process covers).

160. Not available with Electronics Version -V.

Table 15 - Differential Pressure Transmitters (Continued)

Code	Description
CA	CSA intrinsically safe, Zone certified Ex ia
CD	CSA zone certified flameproof Ex d IIC; also explosion proof, dust ignition-proof
CM	CSA multiple certifications (includes CSA Codes CA and CN)
CN	CSA non-incendive, Zone certified Ex nA IIC
CP	CSA multiple certifications (includes CSA Codes CA, CD and CN)
DA	Multi-marked ATEX and IECEx intrinsically safe, Ex ia IIC ¹⁶¹
DD	Multi-marked ATEX and IECEx flameproof, Ex d IIC
DM	Multi-marked ATEX and IECEx multiple certifications, ia, ic ¹⁶¹
DN	Multi-marked ATEX and IECEx protection type n, Ex ic IIC ¹⁶¹
DP	Multi-marked ATEX and IECEx multiple certifications, ia, ic, and d ¹⁶¹
EA	IECEx intrinsically safe, Ex ia IIC ¹⁶¹
ED	IECEx flameproof, Ex d IIC
EM	IECEx multiple certifications, ia, ic, nA ¹⁶¹
EN	IECEx protection type n, Ex ic IIC, or Ex nA ¹⁶¹
EP	IECEx multiple certifications, ia, ic, nA, and d ¹⁶¹
FA	FM Classes I, II and III Division 1 intrinsically safe, AEx ia IIC
FD	FM Classes I, II and III Division 1 explosion proof, dust-ignition proof, Zone approved AEx d IIC
FM	FM multiple certifications (includes FM Codes FA or FN)
FN	Classes I, II and III FM Division 2 non-incendive, Zone approved AEx nA IIC
FP	FM multiple certifications (includes FM Codes FA, FD or FN)
KD	KOSHA Ex d
RA	EAC intrinsically safe, Ex ia ¹⁶¹
RD	EAC flameproof, Ex d ¹⁶¹
RN	EAC protection type n, Ex ic IIC or Ex nA ¹⁶¹
ZZ	No certification
Optional Mounting Bracket Sets^{162 163}	
-M1	Standard Style Painted Steel Bracket with Plated Steel Bolts
-M2	Standard Style Stainless Steel Bracket with Stainless Steel Bolts
-M3	Universal Style Stainless Steel Bracket with Stainless Steel Bolts

161. Not available with Electronics Version -V.

162. Not available with Structure codes F1, F2, F3, and F4 (direct connect seal).

163. Not available with Low Profile (LP1 and LP2) structures.

Table 15 - Differential Pressure Transmitters (Continued)

Code	Description
Optional Adapter Plates^{164 165 166}	
-P1	Adapter Set for MC Coplanar Manifolds, B7 Bolts ¹⁶⁷
-P2	Adapter Set for MC Coplanar Manifolds, 316 ss Bolts ¹⁶⁸
-P3	Adapter Set for MC Coplanar Manifolds, 17-4 ss Bolts ¹⁶⁹
-P4	Adapter Set for MC Coplanar Manifolds, B7M Bolts ¹⁷⁰
-P5	Adapter Set for MT3 Coplanar Manifolds, Traditional Flange, B7 Bolts ¹⁶⁷
-P6	Adapter Set for MT3 Coplanar Manifolds, Traditional Flange, 316 ss Bolts ¹⁶⁸
-P7	Adapter Set for MT3 Coplanar Manifolds, Traditional Flange, 17-4 ss Bolts ¹⁶⁹
-P8	Adapter Set for MT3 Coplanar Manifolds, Traditional Flange, B7M Bolts ¹⁷⁰
Options for Digital Indicator with Pushbuttons	
-L1	Digital Display, Pushbuttons and Window Cover ¹⁷¹
-L2	Substitute Solid Cover over Digital Display ¹⁷²
Optional IEC 61518 Construction^{166 173 174}	
-D1	Single-Ended Process Cover with B7 Steel Bolt; No Connector Screw; MWP=2320 psi
-D2	Double-Ended Process Cover ¹⁷⁵ with B7 Steel Bolt; Size M10 Steel Connector Screw; MWP=1500 psi ^{176 177}
-D3	Single-Ended Process Cover with B7 Steel Bolt; No Connector Screw; MWP=3626 psi
-D4	Double-Ended Process Cover ¹⁷⁵ with B7 Steel Bolt; Size 7/16 Steel Connector Screw; MWP=1500 psi ^{176 177}
-D5	Single-Ended Process Cover with 316 ss Bolt; No Connector Screw; MWP=2175 psi
-D6	Double-Ended Process Cover ¹⁷⁵ with 316 ss Bolt; Size 7/16 316 ss Connector Screw; MWP=1500 psi ^{176 177}
-D7	Single-Ended Process Cover with 17-4 PH Bolt; No Connector Screw; MWP=3626 psi
-D8	Double-Ended Process Cover ¹⁷⁵ with 17-4 PH Bolt; Size 7/16 17-4 PH Connector Screw; MWP=1500 psi ^{176 177}
-D9	Single-Ended Process Cover with 17-4 PH Bolt; No Connector Screw; MWP=5800 psi
Optional Cleaning and Preparation	
-X1	Unit Degreased – for Silicone Fill Sensors Only ¹⁷⁸
-X2	Cleaned and Prepared for Oxygen Service – for Inert Fill Sensors Only ^{179 180}
-X3	Cleaned and Prepared for Chlorine Service ^{179 181}

164. Not available with optional IEC 61518 Construction codes -D1 through -D9.

165. Not available with structures prepared for pressure seals.

166. Available only with Process Connector Type code 0.

167. Not available with Bolting Options -B1, -B2, or -B3.

168. Available only with option -B1.

169. Available only with option -B2.

170. Available only with option -B3.

171. Not available with Electronics Version -V.

172. Available only with Electronics Version -V.

173. See *Maximum Static, Overrange, and Proof Pressure Ratings, page 14* for pressure deratings when certain IEC 61518 options and Bolting Options -B1 or -B3 are specified.

174. Available only with Structure codes 20 through 27. Not available with options -V and -V1.

175. Blind connector supplied.

176. Not available with Mounting Bracket Set options -M1, -M2, and -M3.

177. Temperature limits are derated to -10 and +80°C (14 and 176°F) for optional IEC 61518 Construction codes -D2, -D4, -D6, and -D8 only.

178. Available only with structures that have silicone fill and are not prepared for seals.

179. Available only with structures that have inert fill (excluding Structure code 79) and are not prepared for seals.

180. After units are cleaned and reassembled for oxygen service, they are not rechecked for accuracy. This may affect performance for DP and biplanar GP transmitters.

181. For -X3, standard bolting is replaced with 17-4 ph ss bolts and nuts. Therefore, Bolting codes -B1, -B2, and -B3 are not available with -X3.

Table 15 - Differential Pressure Transmitters (Continued)

Code	Description
Optional Bolting (Process Covers and Process Connectors)^{182 183 184 185}	
-B1	316 ss Bolts and Nuts (high corrosion protection; MWP derated to 2175 psi) ¹⁸⁶
-B2	17-4 PH ss Bolts and Nuts (bright acid tin coated corrosion protection with no pressure derating)
-B3	B7M Bolts and 2HM Nuts (conforms to NACE MR0175/MR0103, Class II; MWP derated to 2900 psi) ¹⁸⁶
Optional Conduit Thread Adapters^{187 188}	
-A1	Hawke-Type 1/2 NPT Brass Cable Gland
-A3	M20 Connector
Optional Custom Factory Configuration	
-C1	Custom Factory Calibration (Calibration and Unit Tags Required) ¹⁸⁹
-C2	Custom Factory Configuration (requires Configuration Form to be filled out)
Optional Electronics Housing Features	
-Z1	External Zero Adjustment ¹⁹⁰
-Z2	Custody Transfer Lock and Seal ¹⁹¹
-Z3	External Zero Adjustment and Custody Transfer Lock/Seal ^{190 191}
Optional Ermeto Connectors	
-E3	316 ss for Connecting 6 mm Tubing to 1/4 NPT Process Connector ¹⁹²
-E4	316 ss for Connecting 12 mm Tubing to 1/2 NPT Process Connector ¹⁹³
Optional Manifold Configurations	
-H1	Manifold Mounted to Transmitter and Pressure Tested (1.5 times transmitter range or 1.5 times manifold rating, whichever is less)
-H2	Manifold Mounted to Transmitter and Pressure Tested (Certificate)
Optional SIL 2 Selections¹⁹⁴	
-S1	Yellow Cover for SIL2 on Electronics/Indicator Side of Housing
-S2	Red Cover for SIL2 on Electronics/Indicator Side of Housing

182. Not available with Structure codes 78 and 79 (PVDF process covers).

183. Not available with optional IEC 61518 Construction codes -D1 through -D9.

184. For stainless steel bolts with IEC 61518 construction, specify -D5 to -D9, as required, instead of -B1 or -B2.

185. Not available with structures that have Monel process covers.

186. See *Maximum Static, Overrange, and Proof Pressure Ratings, page 14* for pressure deratings when certain IEC 61518 options and Bolting Options -B1 or -B3 are specified.

187. Not available with Electrical Certification codes that end in D or P.

188. Available with Conduit Connection and Housing Material codes 1 and 3 only.

189. Not available as a selection for the Value (05S) transmitter because it is standard for these models.

190. Not available with Electronics Version -V.

191. Cover locks are provided as standard with Electrical Certification codes that end in D or P (flameproof).

192. Available only with Structure codes 20 to 27, and Process Connector codes 0 and 1.

193. Available only with Structure codes 20 to 27, and Process Connector code 2.

194. Available only with Electronics Version -T.

Table 15 - Differential Pressure Transmitters (Continued)

Code	Description
Miscellaneous Optional Selections	
-G1	Metal O-Ring for Pressure Seals in Vacuum Service ^{195 196}
-GP	Gold Plated Diaphragm ^{197 198 199}
-J	Low Temperature Operative Limit -50°C (-58°F) ^{200 201 202 203}
-K2	FoxDoc DVD-ROM (instead of "Getting Started" Guide)
-T	Supplemental Customer Tag (Stainless Steel Tag Wired onto Transmitter)
-V	Supply Vent Screw in Side of Each Process Cover ²⁰⁴
-V1	Omit Vent Screw in Side of Each Process Cover ²⁰⁵
-Y	Static Pressure Rating to 40 MPa (5800 psi) and 17-4 ss Bolts and Nuts ^{201 206 207 208}

195. When the pressure seal is used in vacuum applications, -G1 is required. This selection substitutes a vacuum service metal gasket for the standard PTFE process cover gasket.

196. Available only with structure codes for pressure seals.

197. Available only with Structure code 22.

198. Not available with options -X1, -X2, or -X3.

199. Not available with the Value (05S) transmitter.

200. Not available with Electronics Version -V.

201. Not available with Structure codes 78 and 79 (PVDF process covers).

202. Not available with Optional IEC 61518 Construction codes -D2, -D4, -D6, and -D8.

203. Not available with Traditional, LP1, or LP2 structures with inert fill fluid.

204. Available only with Traditional Structure codes 20 to 49.

205. Available only with LP1 Direct Mount structures with 316 ss process covers.

206. Not available with structures prepared for pressure seals.

207. Not available with Bolting Options -B1, -B2, or -B3.

208. Not available with structures that have Monel process covers.

Transmitter Parts

Warning

▲ WARNING

RISK OF MOISTURE INGRESS

To maintain IEC IP66/IP67 and NEMA Type 4X protection, plug the unused conduit opening with the metal plug provided. Use a suitable thread sealant on both conduit connections. In addition, the threaded housing covers must be installed. Turn covers to seat the o-ring into the housing, then continue to hand-tighten until the cover contacts the housing metal-to-metal.

Failure to follow these instructions can result in death or serious injury.

Parts for Direct Connect AP and GP Transmitters

Figure 83 - Direct Connect Transmitters

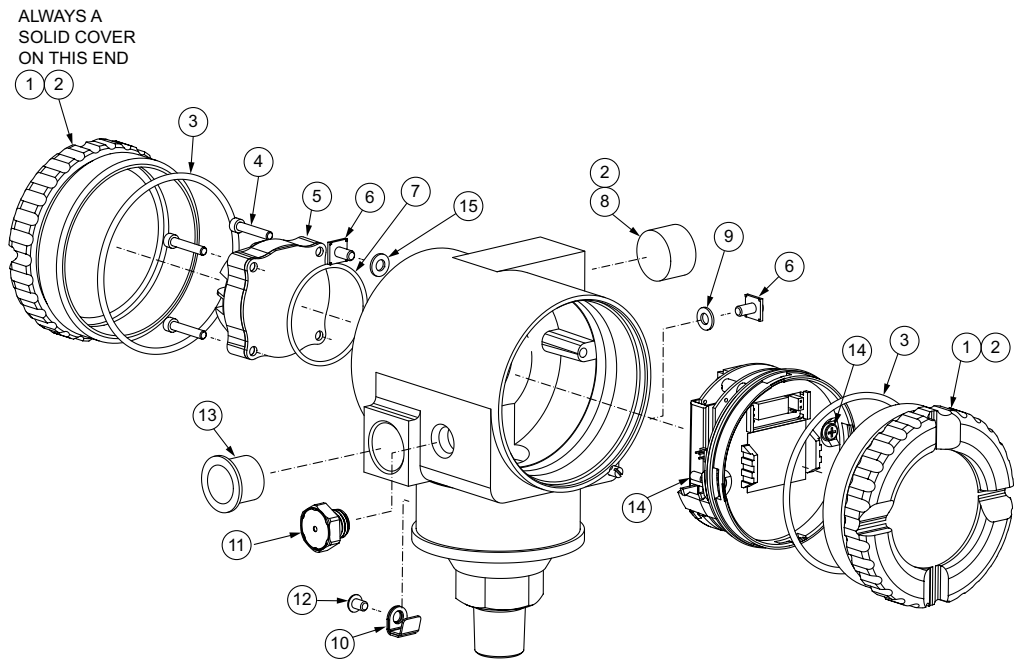

Table 16 - Parts for Direct Connect Transmitters

Item	Part No.	Qty.	Part Name
1	Cover, Electronics Housing; see <i>Housing Covers</i> , page 147. Also see <i>LCD Indicator (Digital Display) Assembly (Option -L1)</i> , page 154.		
2	Below	1	Grease, 1.75 oz. Tube
	X0180JB		Lubit-8 for Transmitters with Aluminum Housing
	X0114AA		Never-Seez for Transmitters with Stainless Steel Housing
3	Below	2	O-Ring, Cover
	X0201FC		without -J Option
	X0201QH		with -J Option

Table 16 - Parts for Direct Connect Transmitters (Continued)

Item	Part No.	Qty.	Part Name
4	Below	4	Screw, Terminal Block Assembly, 0.138-32 x 0.750
	X0133UW		Steel Screw - used with Aluminum Housing
	X0133VP		316 ss Screw - used with 316 ss Housing
5	D0149YB	1	Terminal Block Assembly (Electronics Version -T)
6	D0162VJ	2	Screw Assembly, Ground, 0.164-32 x 0.750
7	Below	1	O-Ring
	X0144KR		without -J Option
	X0201QR		with -J Option
8	Below	1	Pipe Plug for Unused Conduit Connection – see <i>Warning, page 133</i>
	B0139CA		Aluminum, 1/2 NPT; with Housing Code 1
	B0139SK		316 ss, 1/2 NPT; with Housing Code 3
	D0179FJ		Aluminum, M20; with Housing Code 5
	D0179FK		316 ss, M20; with Housing Code 6
9	X0173YA	1	Washer, Ext. Ground, 0.196 ID, 0.383 OD
10	D0197PS	1	Retention Clip
11	X0179ME	1	Vent Plug; for GP Transmitter with sanitary or pulp and paper seals only
12	X0174EX	1	Screw, Button Head; 0.164-32 x 0.25 long
13	S0102BT	1	Plug, Poly (remove prior to Transmitter installation)
14	Below	2	Screw, Captive, Pan Head, 0.138-32 x 0.615
	D0162VM		Steel Screw - used with Aluminum Housing
	D0166CY		316 ss Screw - used with 316 ss Housing

Parts for Biplanar AP and GP Transmitters

Figure 84 - Biplanar Transmitter Topworks

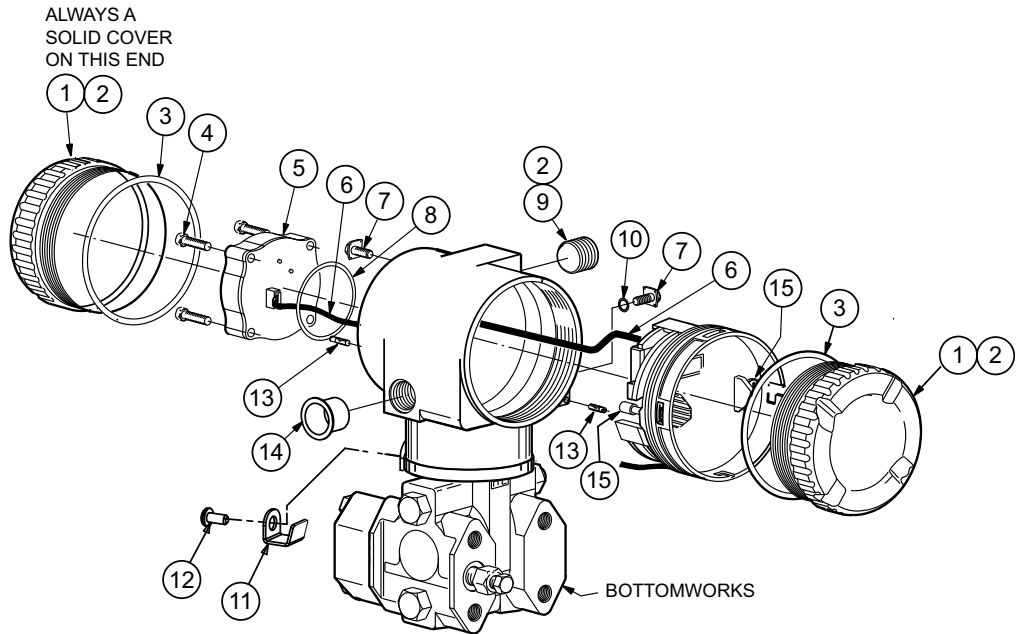

Table 17 - Parts for Biplanar Transmitter Topworks

Item	Part No.	Qty.	Part Name
1	Cover, Electronics Housing; see <i>Housing Covers</i> , page 147 Also see <i>LCD Indicator (Digital Display) Assembly (Option -L1)</i> , page 154.		
2	Below	1	Grease, 1.75 oz. Tube
	X0180JB		Lubit-8 for Transmitters with Aluminum Housing
	X0114AA		Never-Seez for Transmitters with Stainless Steel Housing
3	Below	2	O-Ring, Cover
	X0201FC		without -J option
	X0201QH		with -J option
4	Below	4	Screw, Terminal Block Assembly, 0.138-32 x 0.750
	X0133UW		Steel Screw - used with Aluminum Housing
	X0133VP		316 ss Screw - used with 316 ss Housing
5	D0149YB	1	Terminal Block Assembly with Power Cable (Electronics Version -T)
6	n/a	n/a	Power Cable, included with Terminal Block Assembly
7	D0162VJ	4	Screw Assembly, Ground, 0.164-32 x 0.375
8	Below	1	O-Ring
	X0144KR		without -J option
	X0201QR		with -J option

Table 17 - Parts for Biplanar Transmitter Topworks (Continued)

Item	Part No.	Qty.	Part Name
9	Below	1	Pipe Plug for Unused Conduit Connection – see <i>Warning, page 133</i>
	B0139CA		Aluminum, 1/2 NPT; with Housing Code 1
	B0139SK		316 ss, 1/2 NPT; with Housing Code 3
	D0179FJ		Aluminum, M20; with Housing Code 5
	D0179FK		316 ss, M20; with Housing Code 6
10	X0173YA	1	Washer, Ext. Ground, 0.196 ID, 0.383 OD
11	D0197PS	1	Retention Clip
12	X0174EX	1	Screw, Button Hd; 0.164-32 x 0.25
13	D0162WM	2	Screw, Lock, 0.164-32; part of Optional Selection -Z2; see <i>Custody Transfer Lock and Seal (Option -Z2), page 155</i>
14	S0102BT	1	Plug, Poly (remove prior to Transmitter installation)
15	Below	2	Screw, Captive, Pan Head, 0.138-32 x 0.615
	D0162VM		Steel Screw - used with Aluminum Housing
	D0166CY		316 ss Screw - used with 316 ss Housing

Figure 85 - Biplanar Transmitter Bottomworks for Use with Traditional Structures

**BOTTOMWORKS WITH
PROCESS CONNECTOR
CODES F1 TO F6**

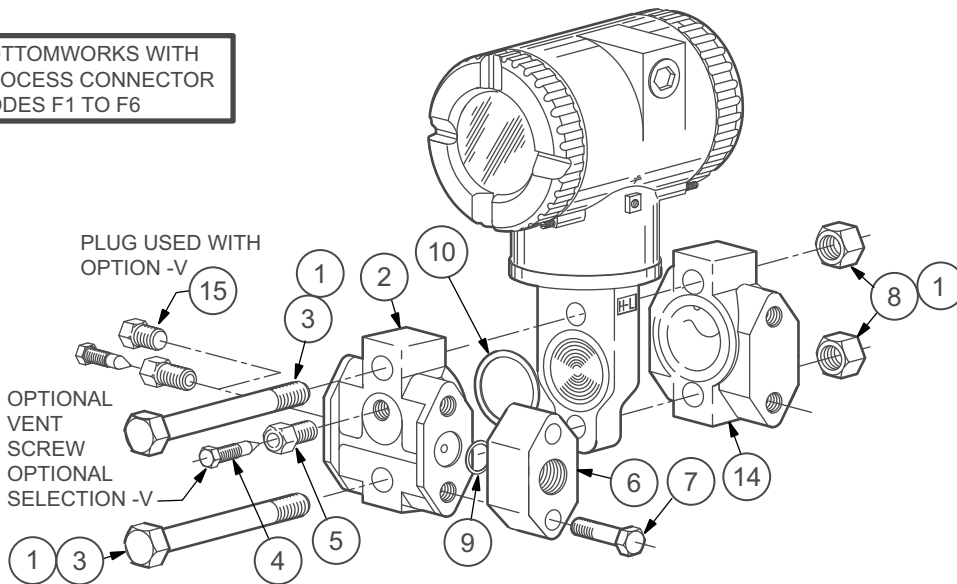

**BOTTOMWORKS WITH
OPTION -D1, -D3, -D5, -D7**

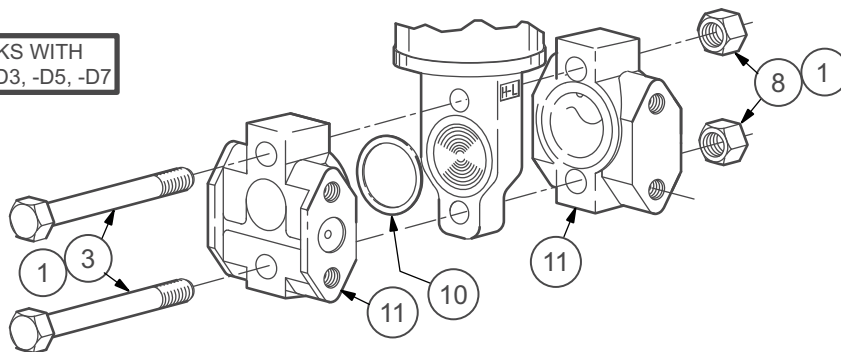

**BOTTOMWORKS WITH
OPTION -D2, -D4, -D6, -D8**

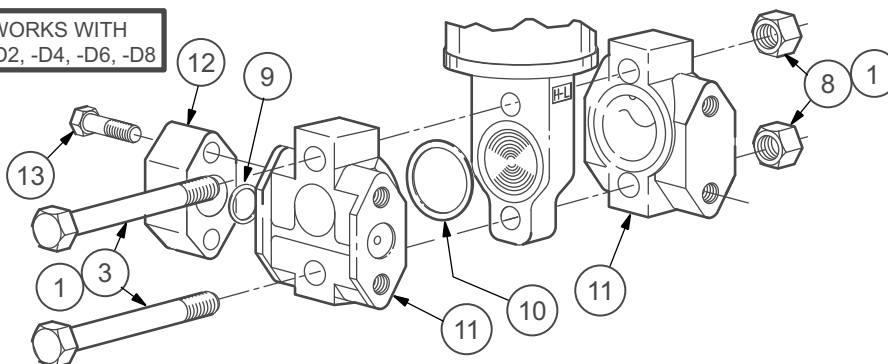

Table 18 - Parts for Biplanar Transmitter Bottomworks for Use with Traditional Structures

Item	Part No.	Qty.	Part Name
1	Below	1	Grease, 1.75 oz. Tube
	X0118CC		Lubriplate for Transmitters with Aluminum Housing
	X0114AA		Never-Seez for Transmitters with Stainless Steel Housing
2	Below	1	Process Cover (Process Connector Type codes F1 - F6)²⁰⁹
	D0161NA		High Side, 316 ss
	D0161NC		High Side, Nickel Alloy ²¹⁰
	D0161ND		High Side, Monel
	D0161NE		Side Vent, 316 ss
	D0161NG		Side Vent, Nickel Alloy ²¹⁰
	D0161NH		Side Vent, Monel
3	Below	2	Screw, hex head, 0.500-13 x 3.5
	X0173RP		2H (ASTM A193, Gr. B7 [std])
	X0173TQ		316 ss (ASTM F593, Group 2) (Options -B1, -D5, -D6)
	X0173UK		ASTM A193, Gr. B7M (Option -B3)
	X0173TD		17-4 ss (ASTM A564, Type 630) (Options -B2, -D7, -D8)
4	Below	2	Vent Screw
	B0138MJ		316 ss (std)
	B0138MK		Monel ²⁰⁹
	D0175PQ		Nickel alloy ^{209 211}
5	Below	1	Vent Plug²¹²
	D0161QT		316 ss (std)
	D0161QU		Monel ²⁰⁹
	D0175PP		Nickel alloy ^{209 211}
6	1 Process Connector (see <i>Process Connectors for Biplanar Transmitters with Traditional Structures, page 139</i>)		
7	Below	2	Screw, hex head, 0.438-20 x 1.5 (for threaded connectors, Codes F1 - F4)
	X0100MN		ASTM A193 Gr. B7 (std)
	X0171VP		ASTM A193, Gr. B7M (Option -B3)
	X0118AX		17-4 Stainless Steel (Options -B2, -D7, -D8)
	N1205RQ		316 ss (Options -B1, -D5, -D6)
	Below		Screw, hex head, 0.438-20 x 1.0 (for weld neck connectors, Code F6)
	X0100NT		ASTM A193, Gr. B7 (std)
	X0171VN		ASTM A193, Gr. B7M (Option -B3)
	X0118AY		17-4 Stainless Steel (Option -B2)
	X0173TP		316 ss (Option -B1)

209. Metallic process wetted material conforming to NACE Standard MR0175 and MR0103.

210. Equivalent to Hastelloy® C. Hastelloy is a registered trademark of Haynes International, Inc.

211. Equivalent to Hastelloy® C-276. Hastelloy is a registered trademark of Haynes International, Inc.

212. For simplified calibration, install F0101ES screw for pressure up to 0.7 MPa (100 psi).

Table 18 - Parts for Biplanar Transmitter Bottomworks for Use with Traditional Structures (Continued)

Item	Part No.	Qty.	Part Name
8	Below	2	Nut, hex head, 0.500-13
	X0173RN		Nut, hex head, 0.500-13
	X0173UL		ASTM A194, Gr. 2HM (Option -B3)
	X0173UJ		17-4 ss (ASTM F594, Group 2) (Options -B2, -D7, -D8)
	X0173TR		316 ss (ASTM F594, Group 2) (Options -B1, -D5, -D6)
9	D0114RB	1	Gasket, PTFE
10	D0161QQ	1	Glass-filled PTFE (standard)
11	Below	1	Cover, 316 ss
	D0161NK		High Side, Single Ended Process Connection M10, ss (Option -D1)
	D0161NM		High Side, Single Ended Process Connection 7/16, ss (Options -D3, -D5, -D7)
	D0161NN		Double Ended Process Connection M10, ss (Option -D2)
	D0161NA		Double Ended Process Connection 7/16, ss (Options -D4, -D6, -D8)
12	D0153RK	1	Kidney Flange, Blind, 316 ss - for use with Options -D2, -D4, -D6, and -D8 (for double-ended process cover)
13	Below	4	Screw, Hex Head, Steel, for Blind Kidney Flange - for Options -D2, -D4, -D6, -D8
	X0173MJ		M10 x 1.5 x 40 mm, for Option -D2
	X0100MN		0.437-20 x 1.5 in, for Options -D4, -D6, and -D8
14	Below	1	Cover, Low Side - for Process Connector Codes F1 - F6
	D0161NR		M10, ss
	D0161NP		7/16, ss
15	Below	1	Pipe Plug
	D0161LU		316 ss (std)
	D0161LV		Monel
	D0161LW		Nickel alloy ²¹³

Process Connectors

Table 19 - Process Connectors for Biplanar Transmitters with Traditional Structures

Process Connector Code	Connector Description	Used with Cover Material		
		Stainless Steel	Nickel Alloy ²¹⁴	Monel
F1	1/4 NPT	N0141XT	—	N0141XK
F2	1/2 NPT	N0141XN	B0139JW	N0141XL
F3	Rc 1/4	B0139BD	—	N0139BC

213. Equivalent to Hastelloy® C-276. Hastelloy is a registered trademark of Haynes International, Inc.

214. Equivalent to Hastelloy® C. Hastelloy is a registered trademark of Haynes International, Inc.

Table 19 - Process Connectors for Biplanar Transmitters with Traditional Structures (Continued)

Process Connector Code	Connector Description	Used with Cover Material		
		Stainless Steel	Nickel Alloy ²¹⁵	Monel
F4	Rc 1/2	B0139BG	B0139JV	B0139BF
F6	1/2 Schedule 80 Weld Neck	N0141XR	–	D0143CZ

Parts for DP Transmitters

Figure 86 - DP Transmitter Topworks

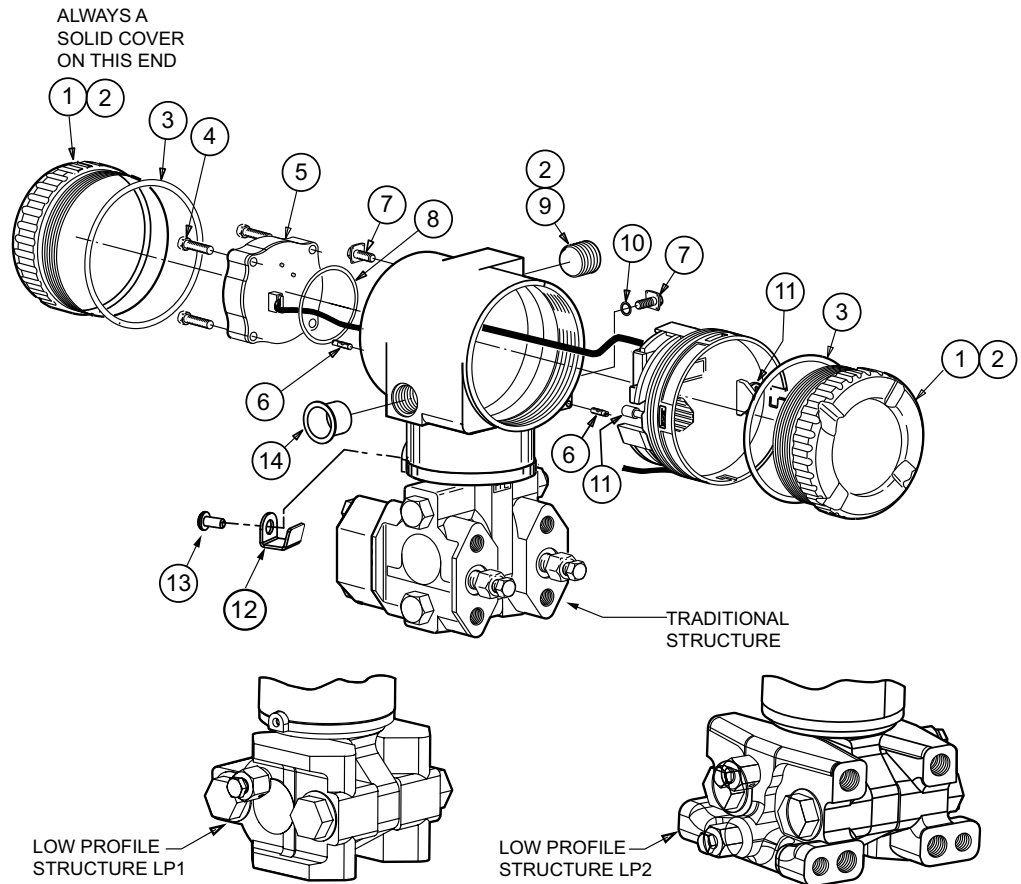

Table 20 - Parts for DP Transmitter Topworks

Item	Part No.	Qty.	Part Name
1	Cover, Electronics Housing; see <i>Housing Covers</i> , page 147. Also see <i>LCD Indicator (Digital Display) Assembly (Option -L1)</i> , page 154.		
2	Below	1	Grease, 1.75 oz. Tube
	X0180JB		Lubit-8 for Transmitters with Aluminum Housing
	X0114AA		Never-Seez for Transmitters with Stainless Steel Housing
3	Below	2	O-Ring, Cover
	X0201FC		without -J option
	X0201QH		with -J option

215. Equivalent to Hastelloy® C. Hastelloy is a registered trademark of Haynes International, Inc.

Table 20 - Parts for DP Transmitter Topworks (Continued)

Item	Part No.	Qty.	Part Name
4	Below	4	Screw, Terminal Block Assembly, 0.138-32 x 0.750
	X0133UW		Steel Screw - used with Aluminum Housing
	X0133VP		316 ss Screw - used with 316 ss Housing
5	D0149YB	1	Terminal Block Assembly with Power Cable (Electronics Version -T)
6	D0162WM	2	Screw, Lock, 0.164-32; part of Optional Selection -Z2; see <i>Custody Transfer Lock and Seal (Option -Z2)</i> , page 155
7	D0162VJ	4	Screw Assembly, Ground, 0.164-32 x 0.375
8	Below	1	O-Ring
	X0144KR		without -J option
	X0201QR		with -J option
9	Below	1	Pipe Plug for Unused Conduit Connection – see <i>Warning</i>, page 133
	B0139CA		Aluminum, 1/2 NPT; with Housing Code 1
	B0139SK		316 ss, 1/2 NPT; with Housing Code 3
	D0179FJ		Aluminum, M20; with Housing Code 5
	D0179FK		316 ss, M20; with Housing Code 6
10	X0173YA	1	Washer, Ext. Ground, 0.196 ID, 0.383 OD
11	Below	2	Screw, Captive, Pan Head, 0.138-32 x 0.615
	D0162VM		Steel Screw - used with Aluminum Housing
	D0166CY		316 ss Screw - used with 316 ss Housing
12	D0197PS	1	Retention Clip
13	X0174EX	1	Button Head Screw; 0.164-32 x 0.25 long
14	S0102BT	1	Poly Plug (remove prior to Transmitter installation)

Figure 87 - DP Transmitter Bottomworks for Use with Traditional Structures

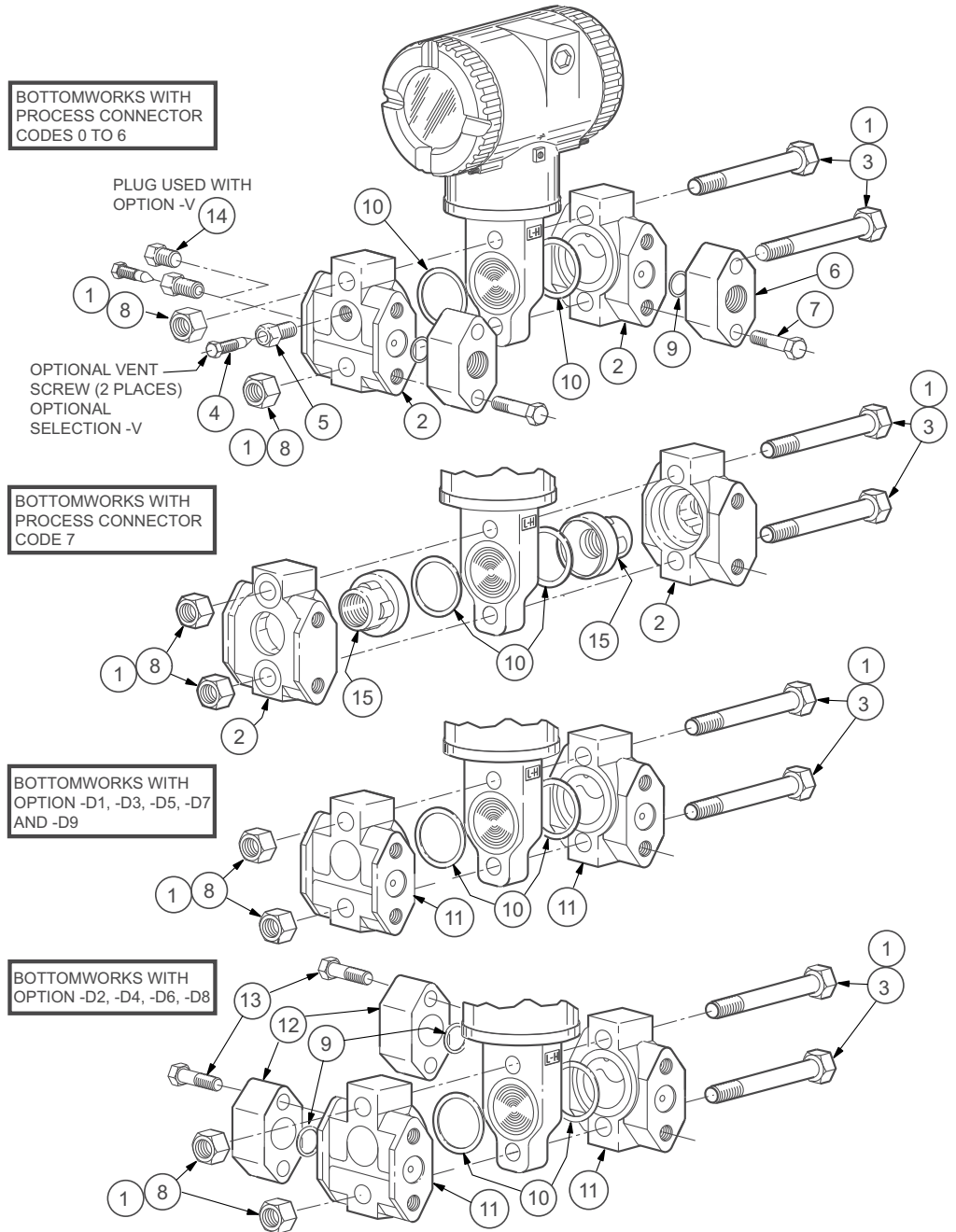

Table 21 - Parts for DP Transmitter Bottomworks for Use with Traditional Structures

Item	Part No.	Qty.	Part Name
1	Below	1	Grease, 1.75 oz. Tube
	X0118CC		Lubriplate for Transmitters with Aluminum Housing
	X0114AA		Never-Seez for Transmitters with Stainless Steel Housing
2	Below	2	Process Cover for use with Process Connection Codes 0-6²¹⁶
	D0161NA		316 ss
	D0161NC		Nickel Alloy ²¹⁷
	D0161ND		Monel
	Below		Side Vent Process Cover for use with Process Connection Codes 0-6²¹⁶
	D0161NE		316 ss
	D0161NG		Nickel Alloy ²¹⁷
	D0161NH		Monel
	D0175TB		316 ss Cover for use with Process Connector Code 7 only (PVDF insert fits into cover)
3	Below	2	Screw, Hex Head, 0.500-13 x 3.5
	X0173RP		2H (ASTM A193, Gr. B7 [standard])
	X0173TQ		316 ss (ASTM F593, Group 2) (Options -B1, -D5, -D6)
	B0138MK		ASTM A193, Gr. B7M (Option -B3) ²¹⁶
	X0173TD		17-4 ss (ASTM A564, Type 630) (Options -B2, -D7, -D8, -D9)
4	Below	2	Vent Screw
	B0138MJ		316 ss (standard)
	B0138MK		Monel ²¹⁶
	D0175PQ		Nickel Alloy ^{216 218}
5	Below	2	Vent Plug²¹⁹
	D0161QT		316 ss (standard)
	D0161QU		Monel ²¹⁶
	D0175PP		Nickel Alloy ^{216 218}
6	2 Process Connectors (see <i>Process Connectors for Biplanar Transmitters with Traditional Structures, page 139</i>)		

216. Metallic process wetted material conforming to NACE Standard MR0175 and MR0103.

217. Equivalent to Hastelloy® C. Hastelloy is a registered trademark of Haynes International, Inc.

218. Equivalent to Hastelloy® C-276. Hastelloy is a registered trademark of Haynes International, Inc.

219. For simplified calibration, install F0101ES screw for pressure up to 0.7 MPa (100 psi).

Table 21 - Parts for DP Transmitter Bottomworks for Use with Traditional Structures (Continued)

Item	Part No.	Qty.	Part Name
7	Below	4	Screw, Hex Head, 0.438-20 x 1.5 (for threaded connectors, Codes 1-4)
	X0100MN		ASTM A193 Gr. B7 (standard)
	X0171VP		ASTM A193, Gr. B7M (Option -B3)
	X0118AX		17-4 Stainless Steel (Options -B2, -D7, -D8, -D9, -Y)
	N1205RQ		316 ss (Options -B1, -D5, -D6)
	Below	4	Screw, Hex Head, 0.438-20 x 1.0 (for weld neck connectors, Code 6)
	X0100NT		ASTM A193, Gr. B7 (standard)
	X0171VN		ASTM A193, Gr. B7M (Option -B3)
	X0118AY		17-4 Stainless Steel (Options -B2, -Y)
	X0173TP		316 ss (Option -B1)
8	Below	2	Nut, Hex Head, 0.500-13
	X0173RN		2H (ASTM A193, Gr. B7) (standard) option
	X0173TR		316 ss (ASTM F594, Group 2) (Options -B1, -D5, -D6)
	X0173UJ		17-4 ss (ASTM F594, Group 2) (Options -B2, -D7, -D8, and -D9)
	X0173UL		ASTM A194, Gr. 2HM (Option -B3)
9	D0114RB	2	Gasket, PTFE
10	Below	2	Gasket, Process Cover
	D0161QQ		Glass-filled PTFE (Standard)
	X0145MJ		Viton – for use with Process Connector Code 7 only
11	Below	1	Cover, 316 ss - for use with Options -D1, -D3, -D5, -D7, and -D9
	D0161NK		Single-ended process connection M10 (Option -D1) (High Side)
	D0161NJ		Single-ended process connection M10 (Option -D1) (Low Side)
	D0161NM		Single-ended process connection 7/16 (Options -D3, -D5, -D7) (High Side)
	D0161NL		Single-ended process connection 7/16 (Options -D3, -D5, -D7) (Low Side)
	D0174BU		Single-ended process connection 7/16 (Option -D9) (High Side)
	D0174BT		Single-ended process connection 7/16 (Option -D9) (Low Side)
	Below		2
	D0161NN	Double-ended process connection M10 (Option -D2)	
	D0161NA	Double-ended process connection 7/16 (Options -D4, -D6, -D8)	
12	D0153RK	2	Kidney Flange, Blind, 316 ss - for use with Options -D2, -D4, -D6, and -D8 (for double-ended process cover)
13	Below	4	Screw, Hex Head, steel - for use with Options -D2, -D4, -D6, and -D8
	X0173MJ		M10 x 1.5 x 40 mm, for Option -D2
	X0100MN		0.437-20 x 1.5 in, for Options -D4, -D6, and -D8

Table 21 - Parts for DP Transmitter Bottomworks for Use with Traditional Structures (Continued)

Item	Part No.	Qty.	Part Name
14	Below	2	Pipe Plug, Hex Head, 1/4 NPT
	D0161LU		316 ss
	D0161LV		Monel
	D0161LW		Nickel Alloy ²²⁰
15	D0175TA	2	Insert, PVDF – for use with Process Connector Code 7 only

Figure 88 - DP Transmitter Bottomworks for Use with Low Profile Structures LP1 and LP2

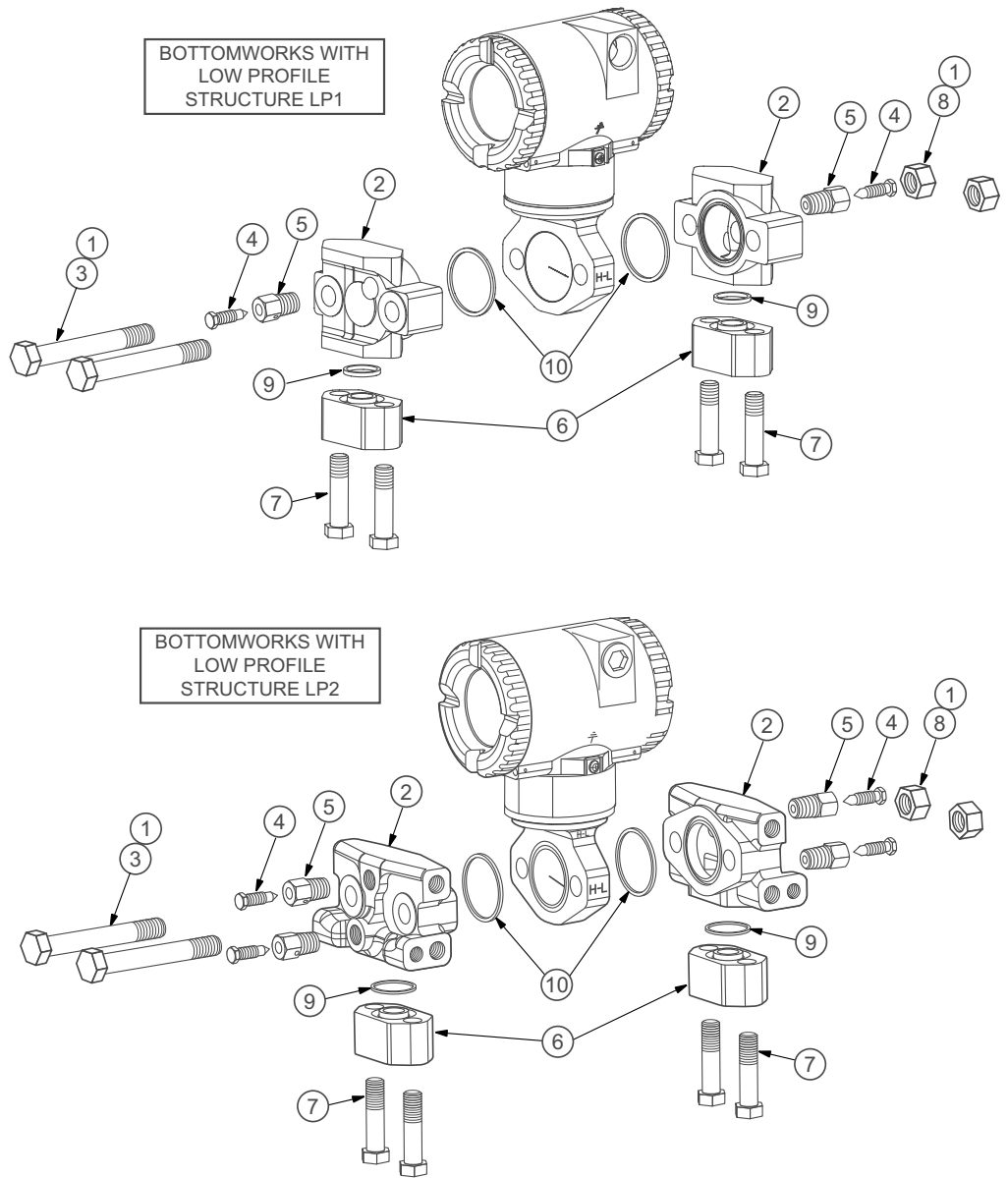

220. Equivalent to Hastelloy® C-276. Hastelloy is a registered trademark of Haynes International, Inc.

Table 22 - Parts for DP Transmitter Bottomworks for Use with Low Profile Structures LP1 and LP2

Item	Part No.	Qty.	Part Name
1	Below	1	Grease, 1.75 oz. Tube
	X0118CC		Lubriplate for Transmitters with Aluminum Housing
	X0114AA		Never-Seez for Transmitters with Stainless Steel Housing
2	Below	1/2 ²²¹	Process Cover with Process Connection Codes 0-6²²²
	D0170WW		with LP1; High Side Cover; 316 ss
	D0170WY		with LP1; Low Side Cover; 316 ss
	D0174BZ		with LP2, High and Low Side Covers; 316 ss
3	Below	2	Screw, Hex Head, 0.500-13 x 3.5
	X0173RP		2H (ASTM A193, Gr. B7 [standard])
	X0173UK		ASTM A193, Gr. B7M (Option -B3)
	X0173TQ		316 ss (ASTM F593, Group 2) (Option -B1)
	X0173TD		17-4 ss (ASTM A564, Type 630) (Options -B2)
4	Below	2/4 ²²¹	Vent Screw
	B0138MJ		316 ss
	D0175PQ		Nickel Alloy ^{222 223}
5	Below	2/4 ²²¹	Vent Plug, 316 ss²²⁴
	D0161QT		316 ss
	D0175PP		Nickel Alloy ^{222 223}
6	Below	2	Process Connectors, used with stainless steel cover
	N0141XT		Tapped for 1/4 NPT, Process Connector Code 1
	N0141XN		Tapped for 1/2 NPT, Process Connector Code 2
	B0139BD		Tapped for R 1/4, Process Connector Code 3
	B0139BG		Tapped for R 1/2, Process Connector Code 4
	N0141XR		1/2 Schedule 80 Weld Neck, Process Connector Code 6
7	Below	4	Screw, Hex Head, 0.438-20 x 1.5 for threaded connectors, Codes 1-4
	X0100MN		ASTM A193 Gr. B7 (Standard)
	X0171VP		ASTM A193, Gr. B7M (Option -B3)
	N1205RQ		316 ss (Option -B1)
	X0118AX		17-4 Stainless Steel (Option -B2)
	Below		Screw, Hex Head, 0.438-20 x 1.0 (for weld neck connectors, Code 6)
	X0100NT		ASTM A193, Gr. B7 (standard)
	X0171VN		ASTM A193, Gr. B7M (Option -B3)
	X0173TP		316 ss (Option -B1)
	X0118AY		17-4 Stainless Steel (Option -B2)

221. The LP2 structure has twice as many vent screws and vent plugs as the LP1 structure. Thus, "2/4" means two for LP1 and four for LP2; "4/8" means four for LP1 and eight for LP2.

222. Metallic process wetted material conforming to NACE Standard MR0175 and MR0103.

223. Equivalent to Hastelloy® C-276. Hastelloy is a registered trademark of Haynes International, Inc.

224. For simplified calibration, install F0101ES screw for pressure up to 0.7 MPa (100 psi).

Table 22 - Parts for DP Transmitter Bottomworks for Use with Low Profile Structures LP1 and LP2 (Continued)

Item	Part No.	Qty.	Part Name
8	Below	1	Nut, 0.500-13
	X0173RN		2H, ASTM A193, Gr. B7 (standard)
	X0173UL		ASTM A194, Gr. 2HM (Option -B3)
	X0173TR		316 ss, ASTM F594, Group 2 (Option -B1)
	X0173UJ		17-4 ss, ASTM F594, Group 2 (Option -B2)
9	D0114RB	2	Gasket, PTFE; Sensor Assembly to Process Cover
10	D0161QQ	2	Gasket, Glass-Filled PTFE; Process Connector to Process Cover

Housing Covers

Description	Aluminum Housing		Stainless Steel Housing	
	without -J Option	with -J Option	without -J Option	with -J Option
Solid Standard Cover	D0162AP		D0162VD	
Electronics End, Extended Window Cover over Digital Display (Option -L1)	D0162LH	D0219EB	D0162VH	D0219ED
Electronics End, Solid Yellow Cover for SIL 2 (Option -S1)	D0219FB		D0219FD	
Electronics End, Yellow Extended Window Cover for SIL 2 (Option -S1) with Digital Display (Option -L1)	D0219FM	D0219FR	D0219FK	D0219FP
Electronics End, Solid Red Cover for SIL 2 (Option -S2)	D0219FA		D0219FC	
Electronics End, Red Extended Window Cover for SIL 2 (Option -S2) with Digital Display (Option -L1)	D0219FL	D0219FQ	D0219FJ	D0219FN

Optional Selections

Refer to *Model Codes, page 114* for available options for each transmitter model.

Mounting Bracket Sets for Direct Connect Transmitters

Figure 89 - Mounting Bracket Sets for Non-Flameproof Direct Connect Transmitter Structures (Options -M1, -M2, -M5, and -M6)

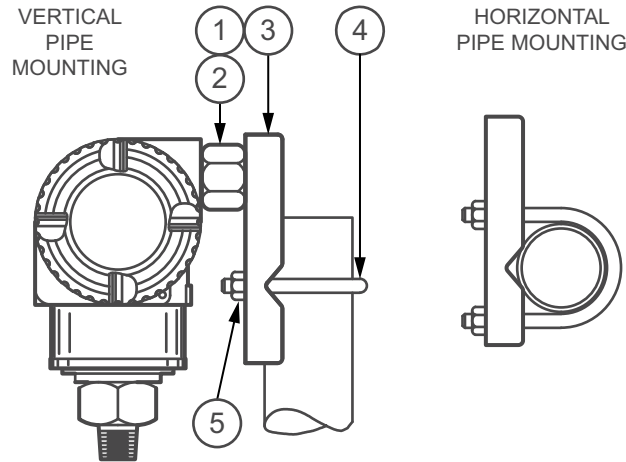

Table 23 - Parts for Mounting Bracket Sets with Painted Steel, for Aluminum Housing (Option -M1)

Item	Part No.	Qty.	Part Name
Set	B0188DL	1	Mounting Bracket Set; for Aluminum Housing; 1/2 NPT Connections (includes items 1–5 below)
1	X0116FB	1	Screw, Hex Head, Plated cs, 0.375-24 x 0.625
2	B0188DN	1	Adapter Plug, 1/2 NPT to 0.375-24, ss
3	N0141ZW	1	Mounting Bracket, Painted Steel
4	D0114SM	1	U-Bolt, Steel
5	0011962	2	Nut, Hex Head, Plated cs, 0.312-18

Table 24 - Parts for Mounting Bracket Sets with Stainless Steel, for Stainless Steel Housing (Option -M2)

Item	Part No.	Qty.	Part Name
Set	N1207AE	1	Mounting Bracket Set; for 316 ss Housing; 1/2 NPT Connections (includes items 1–5 below)
1	P0120RM	1	Screw, Hex Head, ss, 0.375-24 x 0.625
2	B0188DN	1	Adapter Plug, 1/2 NPT to 0.375-24, ss
3	N1205MF	1	Mounting Bracket, ss
4	N1205MX	1	U-Bolt, ss
5	Z1217HV	2	Nut, Hex Head, ss, 0.312-18

Table 25 - Parts for Mounting Bracket Sets with Painted Steel, for Aluminum Housing (Option -M5)

Item	Part No.	Qty.	Part Name
Set	D0179FN	1	Mounting Bracket Set; for Aluminum Housing; M20 Connections (includes items 1–5 below)
1	X0116FB	1	Screw, Hex Head, Plated cs, 0.375-24 x 0.625
2	D0179FM	1	Adapter Plug, M20 to 0.375-24, ss
3	N0141ZW	1	Mounting Bracket, Painted Steel
4	D0114SM	1	U-Bolt, Steel
5	0011962	2	Nut, Hex Head, Plated cs, 0.312-18

Table 26 - Parts for Mounting Bracket Sets with Stainless Steel, for Stainless Steel Housing (Option -M6)

Item	Part No.	Qty.	Part Name
Set	D0179FP	1	Mounting Bracket Set; for 316 ss Housing; M20 Connections (includes items 1–5 below)
1	P0120RM	1	Screw, Hex Head, ss, 0.375-24 x 0.625
2	D0179FM	1	Adapter Plug, M20 to 0.375-24, ss
3	N1205MF	1	Mounting Bracket, ss
4	N1205MX	1	U-Bolt, ss
5	Z1217HV	2	Nut, Hex Head, ss, 0.312-18

Figure 90 - Mounting Bracket Sets for Flameproof Direct Connect Transmitter Structures (Options -M7 and -M8)

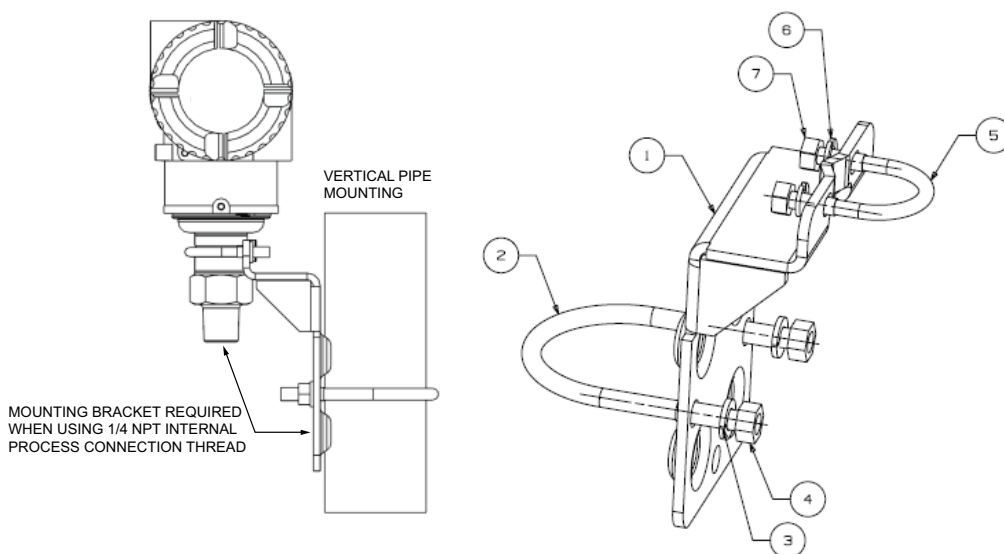

Table 27 - Parts for ATEX Mounting Bracket Sets, Stainless Steel (Option -M7)

Item	Part No.	Qty.	Part Name
Set	D0170ZQ	1	Mounting Bracket Set; ATEX (includes items 1–7 below)
1	D0170ZR	1	Mounting Bracket
2	N1205MX	1	U-Bolt, 5/16-18 ss
3	A2015AB	2	Lock Washer, 5/16-18 ss

Table 27 - Parts for ATEX Mounting Bracket Sets, Stainless Steel (Option -M7) (Continued)

Item	Part No.	Qty.	Part Name
4	X0142BW	2	Nut, Hex Head, 5/16-18 ss
5	D0170ZU	2	U-Bolt, 1/4-20 ss
6	0036504	2	Lock Washer, 1/4 ss
7	X0142BL	2	Nut, Hex Head, 1/4-20 ss

Table 28 - Parts for ATEX Mounting Bracket Sets, Carbon Steel (Option -M8)

Item	Part No.	Qty.	Part Name
Set	D0170ZT	1	Mounting Bracket Set; ATEX (includes items 1–7 below)
1	D0197WF	1	Mounting Bracket
2	D0186MA	1	U-Bolt, 5/16-18 Steel
3	A2004WP	2	Lock Washer, 5/16-18 Steel
4	X0142BV	2	Nut, Hex Head, 5/16-18 Steel
5	D0170ZV	2	U-Bolt, 1/4-20 Steel
6	0042965	2	Lock Washer, 1/4 Steel
7	X0142BK	2	Nut, Hex Head, 1/4-20 Steel

Mounting Bracket Sets for DP and Biplanar Transmitters

Figure 91 - Standard Style Mounting Bracket Sets and Optional Standoff Kits for DP Transmitters (Options -M1 and -M2) and Biplanar Transmitters (Options -M9 and -M0)

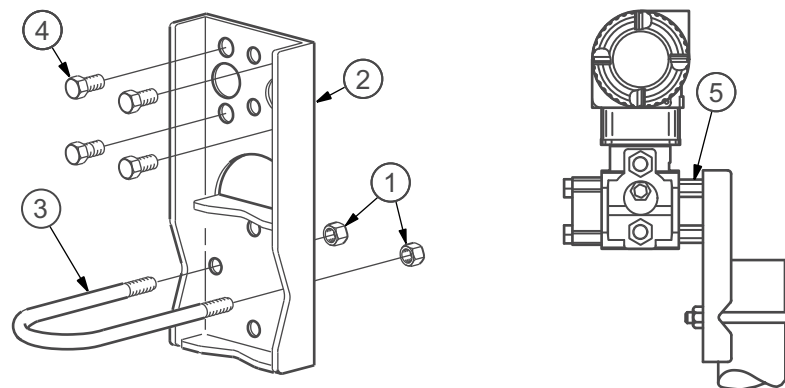

Table 29 - Parts for Standard Style Mounting Bracket Set with Painted Steel (DP Option -M1; Biplanar Option -M9)

Item	Part No.	Qty.	Part Name
Set	N0141ZT	1	Mounting Bracket Set (includes items 1–4 below)
1	0011962	2	Nut, Hex Head, Plated cs, 0.312-18
2	N0141ZW	1	Mounting Bracket, Painted Steel
3	D0114SM	1	U-Bolt, Steel
4	X0100NW	4	Screw, Hex Head, Steel, 0.437-20 x 0.625

Table 30 - Parts for Standard Style Mounting Bracket Set with Stainless Steel (DP Option -M2; Biplanar Option -M0)

Item	Part No.	Qty.	Part Name
Set	N1205YD	1	Mounting Bracket Set (includes items 1–4 below)
1	Z1217HV	2	Nut, Hex Head, ss, 0.312-18
2	N1205MF	1	Mounting Bracket, ss
3	N1205MX	1	U-Bolt, ss
4	P0120RN	4	Screw, Hex Head, ss, 0.437-20 x 0.625

Table 31 - Parts for Optional Standoff Kits (Not Included in -M1/M9 or -M2/M0 Options)

Item	Part No.	Qty.	Part Name
5	D0170ME	1	Kit with Four Steel Standoffs, for use with Option -M1 (DP) or Option -M9 (Biplanar)
	D0170MJ	1	Kit with Four 316 ss Standoffs, for use with Option -M2 (DP) or Option -M0 (Biplanar)

Figure 92 - Universal Style Mounting Bracket Set for DP and Biplanar Transmitters (Option -M3)

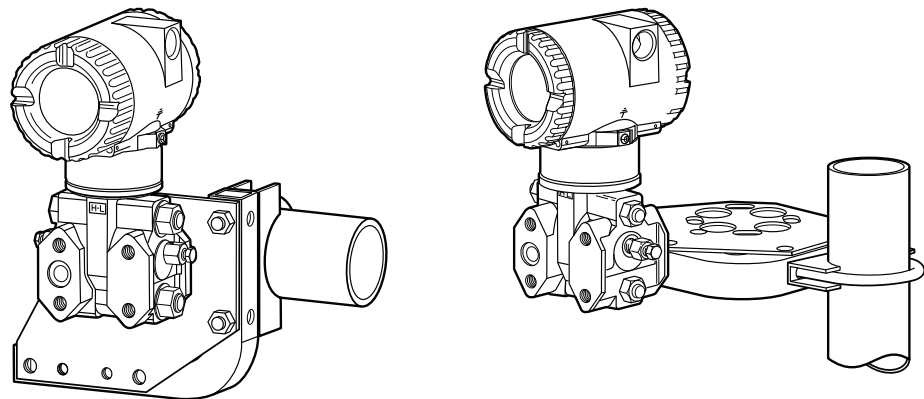
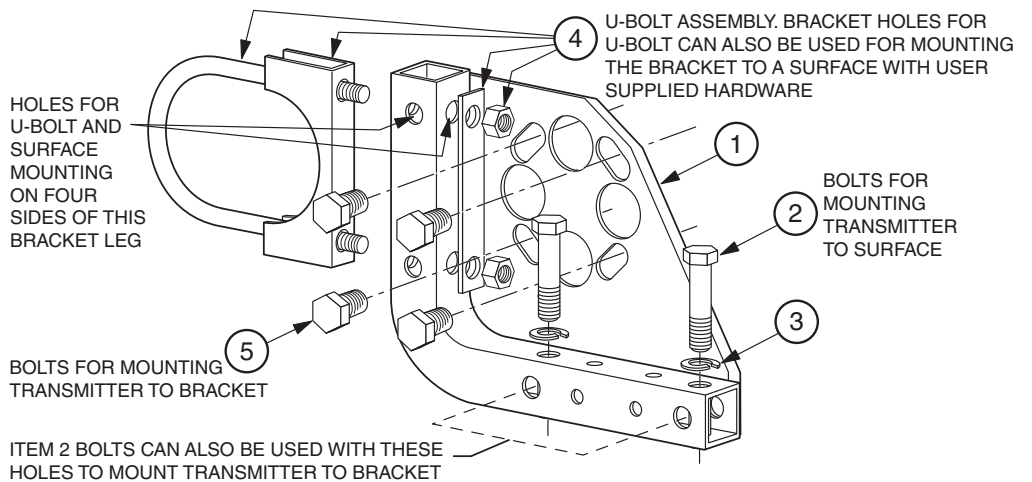

Table 32 - Parts for Universal Style Mounting Bracket Set (Option -M3)

Item	Part No.	Qty.	Part Name
Set	D0170XH	1	Universal Pipe Mounting Set (includes items 1–5 below)
1	D0170VJ	1	Mounting Bracket, ss
2	X0173UR	1	Screw, Hex Head, 0.375-16 x 1.5, , ss
3	A2012TZ	2	Lock Washer, 0.382 I.D., ss
4	D0170VM	1	U-Bolt Assembly, ss, with U-Bolt, 0.312-18; Saddle Clamp; Washer Plate; Nut, Hex Head, 0.312-18
5	P0120RN	4	Screw, hex head, 0.437-20 x 0.625, ss

Vent Screw (Option -V1)

Figure 93 - Vent Screw (Option -V1)

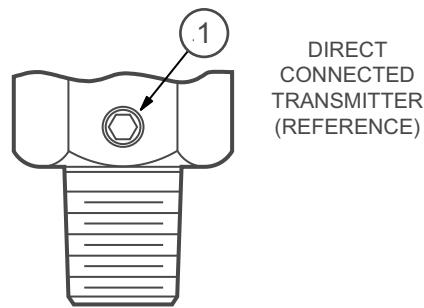

Table 33 - Parts for Vent Screw (Option -V1)

Item	Part No.	Qty.	Part Name
1	D0161SW	1	Vent Screw, 316 ss

Block and Bleed Valve (Options -V2, -V3, and -V4)

Figure 94 - Block and Bleed Valve (Options -V2, -V3, and -V4)

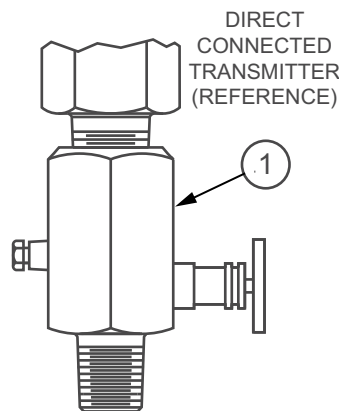

Table 34 - Parts for Block and Bleed Valve (Options -V2, -V3, and -V4)

Item	Part No.	Qty.	Part Name
1	X0172BU	1	Block and Bleed Valve, Carbon Steel (Option -V2)
	X0172BV		Block and Bleed Valve, 316 ss (Option -V3)
	X0172BW		Block and Bleed Valve, 316 ss Body, Monel Trim, NACE Approved (Option -V4)

Adapter Plates (Options -P1 to -P8) for Direct Mounting to Coplanar Manifolds

Figure 95 - Adapter Plates (Options -P1 to -P8) for Direct Mounting to Coplanar Manifolds

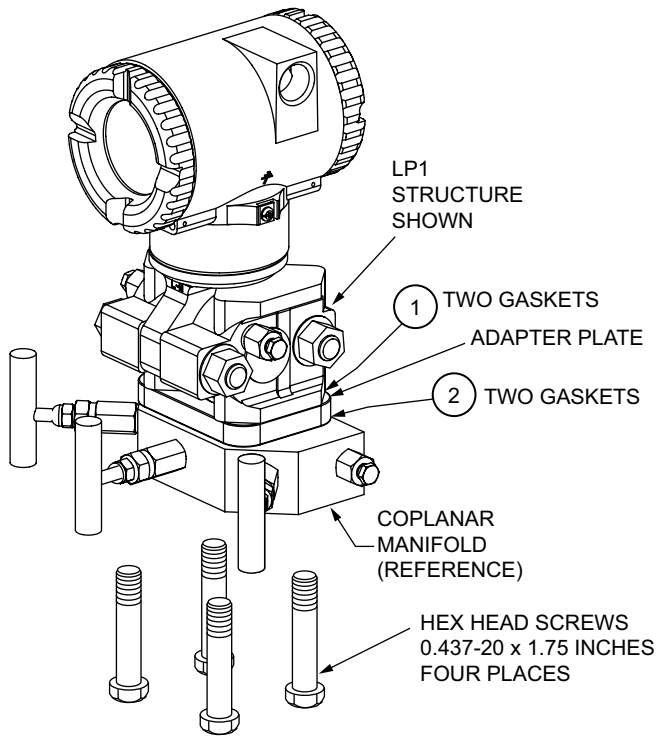

Table 35 - Parts for Adapter Plate Kits -P1 to -P4, Used with “MC” Manifold

Item	Part No.	Qty.	Part Name
n/a	D0170XJ	1	Adapter Plate Kit; B7 Screws; Option -P1
	D0170XM		Adapter Plate Kit; 316 ss Screws; Option -P2
	D0170XN		Adapter Plate Kit; 17-4 ss Screws; Option -P3
	D0170XP		Adapter Plate Kit; B7M Screws; Option -P4

Table 36 - Parts for Adapter Plate Kits -P5 to -P8, Used with “MT3” Manifold

Item	Part No.	Qty.	Part Name
n/a	D0170XQ	1	Adapter Plate Kit; B7 Screws; Option -P5
	D0170XR		Adapter Plate Kit; 316 ss Screws; Option -P6
	D0170XS		Adapter Plate Kit; 17-4 ss Screws; Option -P7
	D0170XT		Adapter Plate Kit; B7M Screws; Option -P8

Table 37 - Gaskets (Included in Kits)

Item	Part No.	Qty.	Part Name
1	D0114RB	2	Gasket, Transmitter to Adapter Plate
2	D0170XK	2	Gasket, Manifold to Adapter Plate

LCD Indicator (Digital Display) Assembly (Option -L1)

Figure 96 - LCD Indicator Assembly (Option -L1)

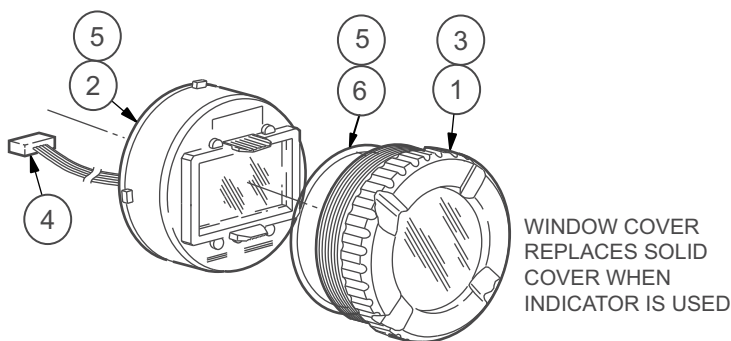

Table 38 - Parts for LCD Indicator Assembly (Option -L1)

Item	Part No.	Qty.	Part Name
1	1 Cover with Window; see <i>Housing Covers</i> , page 147		
2	D0162LQ	1	LCD Indicator Module
3	Below	1	Grease, 1.75 oz. Tube
	X0180JB		Lubit-8 for Transmitters with Aluminum Housing
	X0114AA		Never-Seez for Transmitters with Stainless Steel Housing
4	P0177HB	1	Indicator Cable
5	0048130	1	Grease, Silicone (150 gram tube)
6	Below	2	O-Ring, Cover
	X0201FC		for Transmitter without -J option
	X0201QH		for Transmitter with -J option

Conduit Connections (Options -A1 and -A3)

Figure 97 - Conduit Connections (Options -A1 and -A3)

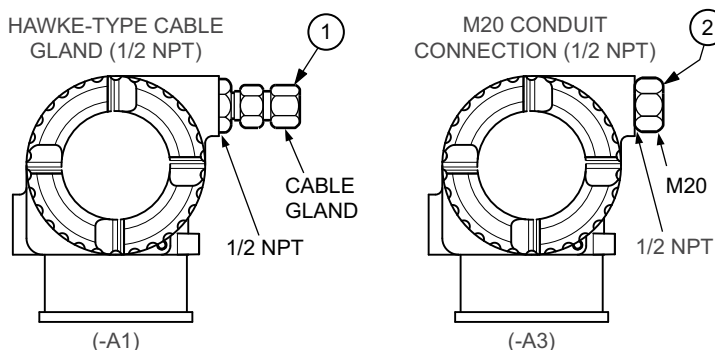

Table 39 - Parts for Conduit Connections (Options -A1 and -A3)

Item	Part No.	Qty.	Part Name
1	N7141HX	1	Hawke-Type 1/2 NPT Brass Cable Gland (Option -A1)
2	N7141DX	1	M20 Connector (Option -A3)

Custody Transfer Lock and Seal (Option -Z2)

Figure 98 - Custody Transfer Lock and Seal (Option -Z2)

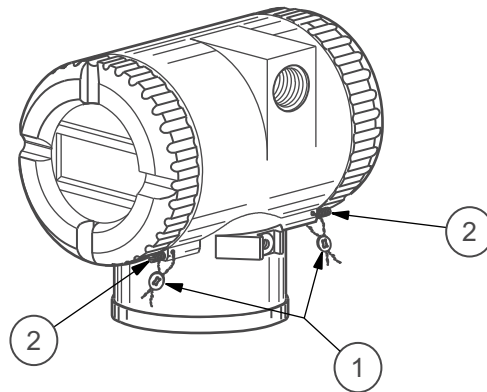

Table 40 - Parts for Custody Transfer Lock and Seal (Option -Z2)

Item	Part No.	Qty.	Part Name
1	S001806	2	Kit with Lock-Out Seal, Wire, and Instructions
2	D0162WM	1	Lock Screw, 0.164-32

Ermeto Connectors (Options -E3 and -E4)

Figure 99 - Ermeto Connectors (Options -E3 and -E4)

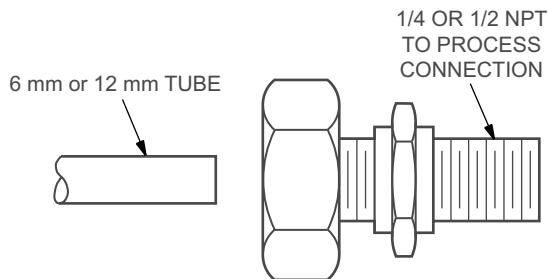

Table 41 - Parts for Ermeto Connectors (Options -E3 and -E4)

Item	Part No.	Qty.	Part Name
n/a	U7002AS	1	Process Connector, 316 ss, 640 bar, 1/4 NPT x 6 mm, Option -E3
	U7002AP		Process Connector, 316 ss, 640 bar, 1/2 NPT x 12 mm, Option -E3

Metric Process Connection (Option -R)

Figure 100 - Metric Process Connection (Option -R)

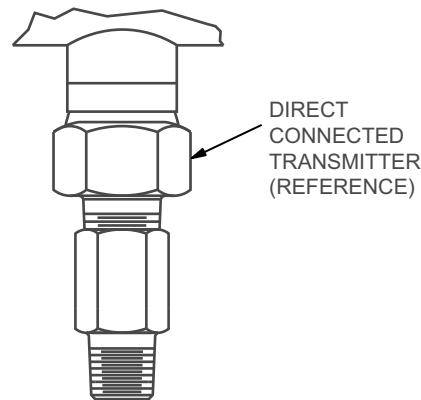

Table 42 - Parts for Metric Process Connection (Option -R)

Item	Part No.	Qty.	Part Name
n/a	X0171ZX	1	Pipe Adapter, 316 ss, 1/2 NPT to Rc 1/2

Recommended Spare Parts

Table 43 - Spare Parts for Direct Connect AP and GP Transmitters

Item No.	Part Number	Part Name	Number of Parts Recommended for		
			1 Inst.	5 Inst.	20 Inst.
<i>See Direct Connect Transmitters, page 133</i>					
3	Below	O-Ring, Cover	0	2	4
	X0201FC	without -J option			
	X0201QH	with -J option			
10	D0197PS	Retention Clip	1	2	4
11	X0179ME	Vent Plug; for Direct Connect GP with sanitary or pulp and paper seals only	1	2	4
12	X0174EX	Button Head Screw	1	2	4
<i>See LCD Indicator (Digital Display) Assembly (Option -L1), page 154</i>					
2	D0162LQ	LCD Indicator Module	0	1	1
3	Below	Grease, 1.75 oz. Tube	1	2	4
	X0180JB	Lubit-8 for Transmitters with Aluminum Housing			
	X0114AA	Never-Seez for Transmitters with Stainless Steel Housing			
5	0048130	Grease, Silicone (150 gram tube)	0	2	4
6	Below	O-Ring, Cover	0	2	4
	X0201FC	for Transmitter without -J option			
	X0201QH	for Transmitter with -J option			

Table 44 - Spare Parts for Biplanar AP and GP Transmitters

Item No.	Part Number	Part Name	Number of Parts Recommended for		
			1 Inst.	5 Inst.	20 Inst.
<i>See Biplanar Transmitter Topworks, page 135</i>					
3	Below	O-Ring, Cover	0	2	4
	X0201FC	without -J option			
	X0201QH	with -J option			
11	D0197PS	Retention Clip	1	2	4
12	X0174EX	Button Head Screw	1	2	4
<i>See Biplanar Transmitter Bottomworks for Use with Traditional Structures, page 137</i>					
4	Below	Vent Screw	0	2/4 ²²⁵	4/8 ²²⁵
	B0138MJ	316 ss (standard)			
	B0138MK	Monel ²²⁶			
	D0175PQ	Nickel alloy ²²⁷ (to NACE Standard MR0175/MR0103)			
5	Below	Vent Plug	0	2/4 ²²⁵	4/8 ²²⁵
	D0161QT	316 ss (standard)			
	D0161QU	Monel ²²⁶			
	D0175PP	Nickel alloy ²²⁷ (to NACE Standard MR0175/MR0103)			
9	D0114RB	Gasket, PTFE	1	2	4
10	D0161QQ	Glass-filled PTFE (Standard)	1	2	4
<i>See LCD Indicator (Digital Display) Assembly (Option -L1), page 154</i>					
2	D0162LQ	LCD Indicator Module	1	2	4
3	Below	Grease, 1.75 oz. Tube	1	2	4
	X0180JB	Lubit-8 for Transmitters with Aluminum Housing			
	X0114AA	Never-Seez for Transmitters with Stainless Steel Housing			
5	0048130	Grease, Silicone (150 gram tube)	0	2	4
6	Below	O-Ring, Cover	0	2	4
	X0201FC	for Transmitter without -J option			
	X0201QH	for Transmitter with -J option			

225. The LP2 structure has twice as many vent screws and vent plugs as the LP1 structure. Thus, "2/4" means two for LP1 and four for LP2; "4/8" means four for LP1 and eight for LP2.

226. Metallic process wetted material conforming to NACE Standard MR0175 and MR0103.

227. Equivalent to Hastelloy® C-276. Hastelloy is a registered trademark of Haynes International, Inc.

Table 45 - Spare Parts for DP Transmitters

Item No.	Part Number	Part Name	Number of Parts Recommended for		
			1 Inst.	5 Inst.	20 Inst.
See <i>DP Transmitter Topworks</i> , page 140					
3	Below	O-Ring, Cover	0	2	4
	X0201FC	without -J option			
	X0201QH	with -J option			
12	D0197PS	Retention Clip	1	2	4
13	X0174EX	Screw, Button Head	1	2	4
See <i>DP Transmitter Bottomworks for Use with Traditional Structures</i> , page 142					
4	Below	Vent Screw	0	2	4
	B0138MJ	316 ss (standard)			
	B0138MK	Monel ²²⁸			
	D0175PQ	Nickel alloy ²²⁹ (to NACE Standard MR0175/MR0103)			
5	Below	Vent Plug	0	2	4
	D0161QT	316 ss (standard)			
	D0161QU	Monel ²²⁸			
	D0175PP	Nickel alloy ²²⁹ (to NACE Standard MR0175/MR0103)			
9	D0114RB	Gasket, PTFE	2	2	4
10	Below	Gasket, Process Cover	2	4	8
	D0161QQ	Glass-filled PTFE (Standard)			
	X0145MJ	Viton (used with Process Connector Code 7)			
15	D0175TA	Insert, PVDF (used with Process Connector Code 7)	2	4	8
See <i>DP Transmitter Bottomworks for Use with Low Profile Structures LP1 and LP2</i> , page 145					
4	Below	Vent Screw	0	2/4 ²³⁰	4/8 ²³⁰
	B0138MJ	316 ss			
	D0175PQ	Nickel alloy ²²⁹			
5	Below	Vent Plug	0	2/4 ²³⁰	4/8 ²³⁰
	D0161QT	316 ss			
	D0175PP	Nickel alloy ²²⁹			
9	D0114RB	Gasket, PTFE	2	4	8
10	D0161QQ	Gasket, Glass-Filled PTFE	2	4	8

228. Metallic process wetted material conforming to NACE Standard MR0175 and MR0103.

229. Equivalent to Hastelloy® C-276. Hastelloy is a registered trademark of Haynes International, Inc.

230. The LP2 structure has twice as many vent screws and vent plugs as the LP1 structure. Thus, "2/4" means two for LP1 and four for LP2; "4/8" means four for LP1 and eight for LP2.

Table 45 - Spare Parts for DP Transmitters (Continued)

Item No.	Part Number	Part Name	Number of Parts Recommended for		
			1 Inst.	5 Inst.	20 Inst.
<i>See LCD Indicator (Digital Display) Assembly (Option -L1), page 154</i>					
2	D0162LQ	LCD Indicator Module	0	1	1
3	Below	Grease, 1.75 oz. Tube	1	2	4
	X0180JB	Lubit-8 for Transmitters with Aluminum Housing			
	X0114AA	Never-Seez for Transmitters with Stainless Steel Housing			
5	0048130	Grease, Silicone (150 gram tube)	0	2	4
6	Below	O-Ring, Cover	0	2	4
	X0201FC	for Transmitter without -J option			
	X0201QH	for Transmitter with -J option			
<i>See Adapter Plates (Options -P1 to -P8) for Direct Mounting to Coplanar Manifolds, page 153</i>					
1	D0114RB	Gasket - Transmitter to Adapter Plate	2	4	8
2	D0170XK	Gasket - Manifold to Adapter Plate	2	4	8

Appendix A: Functional Safety Information

Purpose

This appendix describes the user responsibilities for installation and operation of these pressure transmitters in a Safety Instrumented Function (SIF). In order to ensure the safe usage of this product, all procedures in this appendix must be followed. This appendix should be read in addition to the appropriate sections of this instruction document for the transmitter being installed.

Scope

The information in this appendix applies to the following products if they have a green housing, a firmware version of 2.0 or greater, and “SIL 2” on the data plate.

- IAP**S-T Absolute Pressure Transmitter with HART Communication
- IDP**S-T Differential Pressure Transmitter with HART Communication
- IGP**S-T Gauge Pressure Transmitter with HART Communication

See *Product Identification*, page 162 for the location of the model code.

Acronyms and Definitions

Acronym	Definitions
DCS	Distributed Control System
DD	Dangerous Detected
DU	Dangerous Undetected
FIT	Failures in Time (failures per 1E09 hours)
FTA	Fault Tree Analysis
HFT	Hardware Fault Tolerance
λ	Failure rate
λ_{DD}	Failure rate for Dangerous Detected
λ_{DU}	Failure rate for Dangerous Undetected
λ_S	Failure rate for Safe Detected + failure rate for Safe Undetected
LT	Product Lifetime
MPa	megaPascals
MTTR	Mean Time to Repair
PFD_{AVG}	Average Probability of Failure on Demand
PFH	Probability of Failure per Hour
psi	Pounds per square inch
PTI	Proof Test Interval
SD	Safe Detected
SFF	Safe Failure Fraction
SFRS	Safety Requirements Specification
SIF	Safety Instrumented Function

Acronym	Definitions
SIL	Safety Integrity Level
SU	Safe Undetected

SIL 2 Reference Documents

The following documents are referenced by this appendix, or define or constrain its contents. Where the contents of this appendix conflict with those of a referenced document, the contents of the most recent document shall take precedence. Additional related documents are listed in *Reference Documents, page 9*.

Document Number	Description
PSS 2A-1S05 A	Product Specification Sheet, Value Performance Pressure Transmitters
PSS 2A-1S10 A	Product Specification Sheet, Advanced Performance Pressure Transmitters
PSS 2A-1S05 A	Product Specification Sheet, Premium Performance Pressure Transmitters
MI 020-611	Master Instruction, Pressure Transmitters with HART Communication and SIL 2
MI 020-366	Master Instruction, Pressure Transmitters Operation, Configuration, and Calibration Using a HART Communicator
MI 020-501	Master Instruction, PC50 Intelligent Field Device Tool, Installation and Parts List
MI 020-505	Master Instruction, PC50 Intelligent Field Device Tool, Operation Using HART Communication Protocol
IEC 61508-2010	Functional Safety of Electrical/Electronic/Programmable Electronic Safety-Related Systems

Safety Specifications

Product Identification

Figure 101 - Sample Transmitter Data Plate

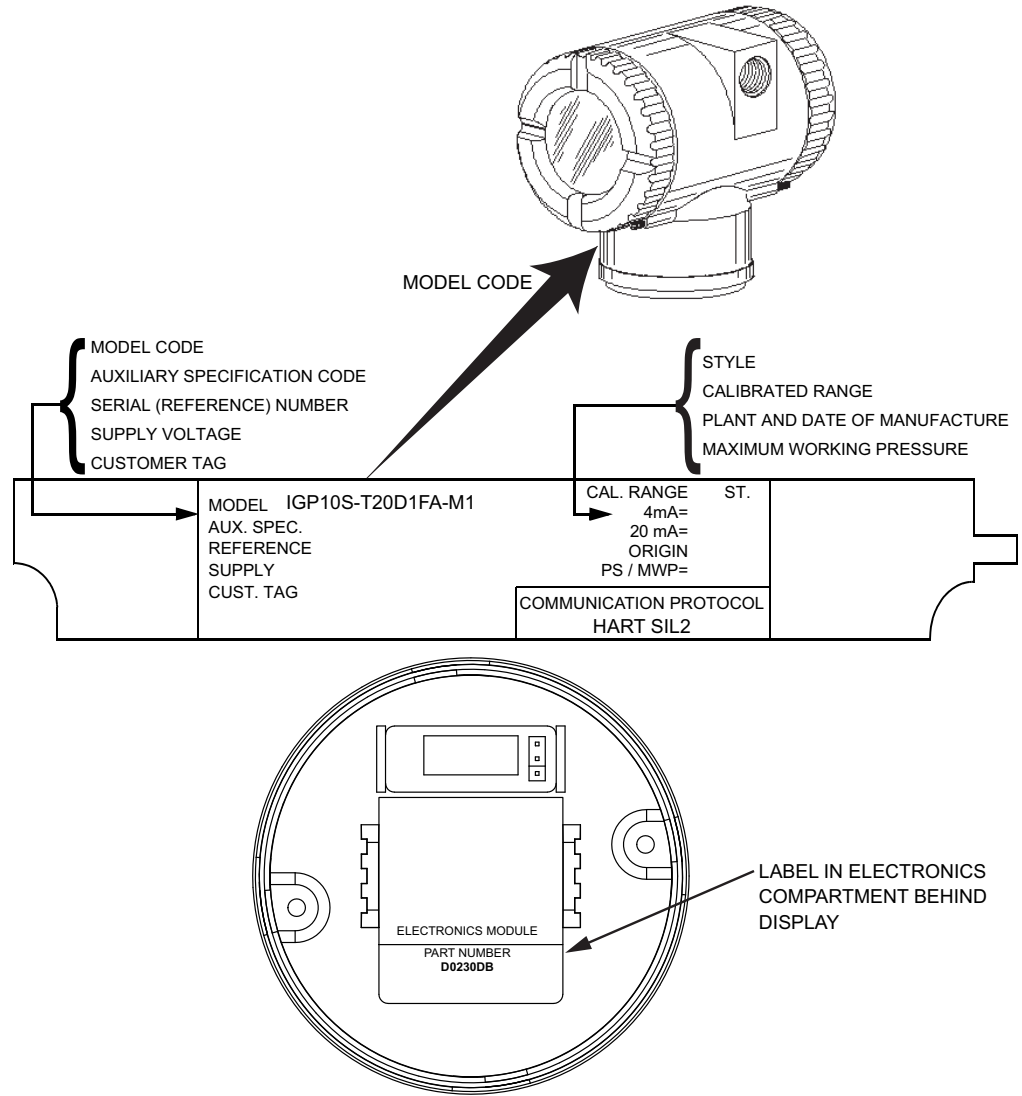

Safety Related Parameters

The following variables and interfaces can be used as part of a Safety Instrumented Function:

Variables: Pressure

Interfaces: 4 to 20 mA analog current

Use in absolute, gauge, or differential pressure measurement applications as indicted by the model code

Safety Accuracy: 2%

▲ WARNING

HAZARD OF OPERATION OUTSIDE OF TEMPERATURE SPECIFICATION

- The Safety Accuracy specification applies when the temperature of the device electronics is within the normal operating temperature range of -40 to +85°C (-40 to +185°F). Outside of this temperature range, the milliamp output may experience greater drift and may not remain within the 2% Safety Accuracy specification.
- For applications that may encounter temperatures beyond the normal operating range, configure the Temperature Sensor Fail Strategy to set the device to Failsafe when the operating temperature limit is exceeded, and ensure that the DCS can recognize Failsafe settings outside of the Safety Accuracy range.
- With the local display or DTM, the Failsafe setting is **AO ALM**. With the DD, the Failsafe setting is **AO Alarm**.

Failure to follow these instructions can result in death, serious injury, or equipment damage.

Safety Response Time: 750 ms maximum (with Damping set to 0 s)

Measurement Updates: Every 250 ms

Low Alarm: In rare cases, certain extreme conditions are signaled within the Low Alarm range independent of the configured setting for the failsafe strategy. For example, a bad processor may result in a 3.6 mA output even if the device is configured to fail to the high MI setting.

▲ WARNING

HAZARD OF IMPROPER MONITORING

To ensure safe fault monitoring, the DCS must be capable of recognizing both the High Alarm and Low Alarm conditions as malfunction indicators.

Failure to follow these instructions can result in death or serious injury.

- The HART interface and/or the local interface (if present) may be used to examine data, but are not to be used as a safety critical means of communication.
- The write protect jumper must be in the Protect position during normal operation as detailed in the configuration and operation section.
- The user can verify that the transmitter is operating in the secured (SIL) mode using a HART Communicator as follows:
 1. From the Top Level **Online** menu, select **Device Setup** and then **Diagnostic Info**.
 2. Verify that the **SIL Mode** item indicates **OK: Required + Active**.
- The transmitter model code offers red or yellow replacement covers to identify that the transmitter is part of a safety loop.

- Pressure transmitters can be used in SIL 2 safety functions in 1oo1 single mode, or in SIL 3 safety functions in 1oo2 dual mode.

Reliability Data

These data are valid with the following requirements:

- The logic solver (user SIF) must detect both out of range currents, both over and under, and must act upon their detection to bring the system to a safe state.
- The system operates in a low demand mode. (The frequency of demands for operation made on the system is no greater than one per year and no greater than twice the proof test frequency.)

Failure Data According to IEC 61508

λ	λ_s	λ_{DD}	λ_{DU}	SFF
1113 FIT	698 FIT	356 FIT	58 FIT	94.76%

The PFD_{AVG} value for a single pressure transmitter is $2.6E-4$ per year. The PFD_{AVG} values shown in the following table support a Proof Test Interval of up to five years. It is the responsibility of the end user to select a Proof Test Interval that satisfies the requirements of the application. Refer to *Periodic Proof Testing, page 169*.

Time (Years)	Time (Hours)	PFD_{AVG}	% of SIL 2
0.25	2190	$6.4E-05$	1.8%
0.5	4380	$1.3E-04$	3.6%
1	8760	$2.6E-04$	7.3%
2	17520	$5.1E-04$	14.6%
5	43800	$1.3E-03$	36.5%

The PFH value for a single pressure transmitter is $5.8E-8$.

The transmitter performs internal diagnostic functions to detect random faults of its hardware. All internal diagnostics are executed to detect faults within the diagnostic test interval of 11 minutes. The transmitter detects and mitigates systematic faults that could result in failure on demand prior to a demand occurring.

Environmental Limits

Parameter	Limits
Sensor Body Temperature	
Silicone fill fluid	-46 and +121°C (-50 and +250°F) ^{231 232}
Fluorinert fill fluid	-29 and +121°C (-20 and +250°F) ²³³
NEOBEE® fill fluid	-18 and +121°C (0 and 250°F)
PVDF inserts	-7 and +82°C (+20 and 180°F)

231. Selection of Option -J extends the low temperature operative limit of transmitters with silicone filled sensors down to -50°C (-58°F).

Performance is not assured below -29°C. Sensor damage may occur if process is frozen. Contact Global Customer Support for availability of this option.

232. -46 and +50°C (-50 and +122°F) for biplanar AP transmitters.

233. -18°C (0°F) for J range (IGP05S transmitters only).

Parameter	Limits
Electronics Temperature	
Without LCD	-40 and +85°C (-40 and +185°F) ^{234 235}
With LCD	-40 and +85°C (-40 and +185°F) ^{234 235 236}
Relative Humidity	0 and 100% ²³⁷
Terminal Voltage	The loop must be designed to provide a minimum of 15.5 V dc at the transmitter terminals to allow for SIS operation up to 21 mA with a safe margin and allowance for HART communication. Refer to the <i>Supply Voltage and Loop Load for SIF Applications</i> , page 165 graph.
Vibration	
Aluminum Housing	Per IEC 60770 for “field with high vibration level or pipeline with high vibration level”: 0.42 mm peak-to-peak displacement from 10 to 60 Hz, 3 “g” constant acceleration input over a frequency range of 60 to 1000 Hz
Stainless Steel Housing	Per IEC 60770 for “field with general application or pipeline with low vibration level”: 0.3 mm peak-to-peak displacement from 10 to 60 Hz, 2 “g” constant acceleration input over a frequency range of 60 to 1000 Hz
Weatherproofing	Dusttight and weatherproof per IEC IP66 and NEMA 4X

Figure 102 - Supply Voltage and Loop Load for SIF Applications

This SIF supply voltage vs load curve allows for a Safety Margin to comply with SIL certification.

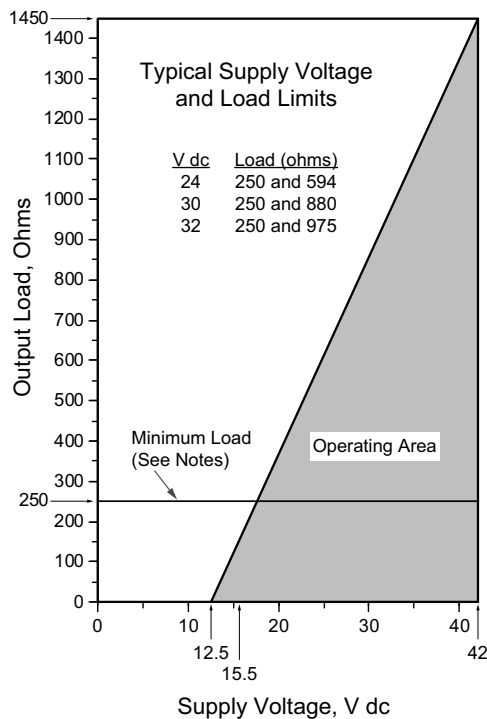

- NOTES:**
1. The minimum voltage for HART communication is 15.5 V dc.
 2. The minimum load for the HART Communicator is 250 ohms.
 3. The transmitter can function with an output load less than the minimum, but using a remote configurator while operating in this area will result in output and/or communication disturbances.

234. -40 and +75°C (-40 and +167°F) for transmitters with ATEX flameproof classification.

235. -40 and +50°C (-40 and +122°F) for biplanar AP transmitters.

236. Display updates are slowed and readability is decreased at temperatures less than -20°C (-4°F).

237. Relative humidity refers to transmitters with housing covers installed and conduit entrances sealed. To maintain IEC IP66/IP67 and NEMA Type 4X protection, plug the unused conduit opening with the metal plug provided. Use a suitable thread sealant on both conduit connections. In addition, the threaded housing covers must be installed. Turn covers to seat the o-ring into the housing, then continue to hand-tighten until the cover contacts the housing metal-to-metal.

⚠ ⚠ WARNING
HAZARD OF OPERATION WITH INSUFFICIENT POWER SUPPLY VOLTAGE
The Safety Accuracy specification applies when the voltage supplied to the terminals of the transmitter is within the normal operating range of 15.5 V dc to 42 V. To be assured of operation within the safety accuracy specification, the installation must include power supply monitoring or other means to ensure that the transmitter is supplied with a supply voltage that is no lower than 12.5 V dc.
Failure to follow these instructions can result in death, serious injury, or equipment damage.

Application Limits

For span range limits, refer to *Span and Range Limits*, page 12.

For maximum static, overrange, and proof pressure limits, refer to *Maximum Static, Overrange, and Proof Pressure Ratings*, page 14.

Electromagnetic Compatibility

This pressure transmitter conforms to the following EMC requirements:

- NAMUR NE21 (August 1998 German and May 1999 English)
- EMC directive 2004/108/EC per EN 61326-3-1
- IEC 61000-4 (parts 2, 4, 5, 8, and 11)
- CISPR16

Lifetime Limits

According to section 7.4.9.5 of IEC 61508-2, a useful lifetime, based on experience, should be assumed.

Although a constant failure rate is assumed by the probabilistic estimation method, this only applies provided that the useful lifetime of components is not exceeded. Beyond their useful lifetime the result of the probabilistic calculation method is therefore meaningless, as the probability of failure significantly increases with time. The useful lifetime is highly dependent on the component itself and its operating conditions - temperature in particular (for example, electrolyte capacitors can be very sensitive).

This assumption of a constant failure rate is based on the bathtub curve, which shows the typical behavior for electronic components. Therefore it is obvious that the PFD_{AVG} calculation is only valid for components that have this constant domain and that the validity of the calculation is limited to the useful lifetime of each component.

This table identifies the components that are contributing to the dangerous undetected failure rate and therefore to the PFD_{AVG} calculation and their estimated useful lifetime.

Table 46 - Useful Lifetime of Components Contributing to λ_{DU}

Type	Useful Life at 40°C
Capacitor (electrolytic) — Tantalum electrolytic, solid electrolyte	Approximately 500,000 hours

As there are no aluminum electrolytic capacitors used, the tantalum electrolytic capacitors are the limiting factors with regard to the useful lifetime of the system. The tantalum electrolytic capacitors that are used in the transmitter have an estimated useful lifetime of about 50 years.

When plant experience indicates a shorter useful lifetime than indicated in this appendix, the number based on plant experience should be used.

Certification Data

- SIL 2 certification is performed by TÜV, an independent laboratory.
- The Pressure Transmitter is classified as a Type B device according to IEC 61508, having a hardware fault tolerance of 0.
 - NOTE:** Type B component: “Complex” component (using microcontrollers or programmable logic); for details see section 7.4.4.1.3 of IEC 61508-2:2010.
- Based on internal diagnostics, the Pressure Transmitter has a Safe Failure Fraction of 94.76% (assuming that the logic solver is configured to detect over-scale and under-scale currents), and therefore may be used up to SIL 2 as a single device.
- The Pressure Transmitter has a proof test interval of up to five years in order to maintain a SIL 2 rating, allowing it to be used as a single device.
 - NOTE:** Per Table 3 of IEC 61508-2:2010 section 7.4.4.2.2, the preceding information allows the Pressure Transmitter, when used in a 1 of 2 system architecture, to be used as a SIL 3 application with an HFT of 1.
- All Pressure Transmitter diagnostics have a maximum Diagnostic Test Interval of 11 minutes.

Personnel

It is the responsibility of the user organization to ensure that personnel involved in the use and maintenance of the product are properly trained and qualified to carry out their activities.

Installation

The Pressure Transmitter is to be installed per this instruction manual. Related documents are listed in the *SIL 2 Reference Documents, page 161* section.

Configuration and Setup

Pressure transmitter configuration and setup are described in this instruction manual. Related documents are listed in *SIL 2 Reference Documents, page 161*. The configuration parameters are repeated here for convenience.

Table 47 - Configuration Parameters

Parameter	Capability	Factory Default	Configurable with		Application Requirement
			Integral Indicator (if applicable)	Remote Configurator ²³⁸	
Descriptors					
Tag	8 characters maximum	TAG	No	Yes	
Long Tag	32 characters maximum	[blank]	No	Yes	
Descriptor	16 characters maximum	DESCRIPTOR	No	Yes	
Message	32 characters maximum	MESSAGE	No	Yes	
Input					
Calibrated Range	LRV to URV in linear units (listed at the end of this table)	See <i>Span and Range Limits</i> , page 12	Yes	Yes	
Output					
Meas #1 Output	4 to 20 mA or Fixed Current	4 to 20 mA	Yes	Yes	
Meas #1 Mode	AP or GP: Linear DP: Linear or type of square root	Linear	Yes	Yes	
Meas #1 EGUs	See the end of this table for a list of linear units and square root units	Same units as Calibrated Range	Yes	Yes	
Meas #2 Mode	AP or GP: Linear DP: Linear or type of square root	Linear	Yes	Yes	
Meas #2 EGUs	See the end of this table for a list of linear units and square root units	Same units as Calibrated Range	Yes	Yes	
Electronics Temperature Sensor Alarms Strategy	Normal operation or failsafe	Normal operation ²³⁹	Yes	Yes	
Failsafe	High or Low	High	Yes	Yes	
External Zero	Enabled or Disabled	Disabled	Yes	Yes	
Damping	0 to 32 seconds	0.25 seconds	Yes	Yes	
Poll Address	0 to 63	0	Yes	Yes	
Loop Current Signaling	On (active/live current) or Off (fixed current) ²⁴⁰	On	Yes	Yes	
LCD Indicator	Meas #1 EGU or % Lin ²⁴¹	Meas # 1 EGU	Yes	No	
Linear Units: inH2O, ftH2O, mmH2O, inHg, mmHg, cmHg, mHg, psi, psf, mbar, bar, g/cm2, kg/cm2, kg/m2, Pa, hPa, kPa, MPa, torr, inWC60, ftWC60, inWC4, ftWC4, mmWC4, cmWC4, mWC4, atm, dy/cm2					
Square Root Units: gal/s, gal/m, gal/h, gal/d, Mgal/d, ft3/s, ft3/m, ft3/h, ft3/d, lgal/s, lgal/m, lgal/h, lgal/d, l/s, l/m, l/h, MI/d, m3/s, m3/m, m3/h, m3/d, NI/h, Nm3/h, Sm3/h, Am3/h, Sft3/m, MSCFD, MMSCFD, bbl/s, bbl/m, bbl/h, bbl/d, g/s, g/m, g/h, kg/s, kg/m, kg/h, kg/d, lb/s, lb/m, lb/h, lb/d, t/m, t/h, t/d, STon/m, STon/h, STon/d, LTon/h, LTon/d, %flow					

Additional Restrictions

- The write protect jumper shall be in the **Protect** position during normal operation (that is, whenever the safety function must be active). To activate write protection, power down the transmitter and remove the display. Then remove the jumper or

238. Remote configurator provides a noninterfering means for the user to perform some setup, configuration, and maintenance activities. See *Additional Restrictions*, page 168.

239. Select the failsafe (non-default) setting for additional SIL diagnostics.

240. Device is not safety compliant if in multidrop mode.

241. Measurement 2 can be displayed at any time by pressing the **ENTER** button, regardless of the local display's configuration.

move it to the lower position as shown on the exposed label. Replace the display and restore power to the transmitter. Refer to *Setting the Write Protect Jumper*, page 43.

- At any time the write protect jumper is not in the **Protect** position, the configuration can be altered by means of the local display or HART Communicator. In this state, the transmitter output is not to be considered to be reliable. Other means of determining whether the safety variable has exceeded its limit shall be implemented for the duration of this state. The jumper shall be returned to the **Protect** position when the calibration and/or configuration activity is complete using the procedure described above.
- The protective function provided by the milliampere output is not available when the local interface (if present) is used to perform manual configuration or calibration operations.
- With user configurable damping set to 0 seconds damping, the pressure transmitter has a worst-case response time of less than 750 ms for a 63% response to a pressure step change. For damping settings other than 0, the user is responsible for performing the worst case response time calculations and for verifying that the resulting response time is appropriate for the application.
- Each configuration change must be verified after it is made. The verification procedure varies depending on the configurator that is used to make the change.
 - When a HART Communicator is used, the user must verify that the transmitter's internal verification process completes as follows:
 1. From the top-level **Online** menu, select **Device Setup** and then **Diagnostic Info**.
 2. The **Database Verify** item changes from **Idle** to **Verifying** when new configuration data is sent to the transmitter. The transmitter then performs internal checks to verify the changes, which takes up to two minutes. The display then changes to **Verify Complete**.
 3. The user must then power cycle the HART Communicator and verify the value shown in each changed parameter.
 - When any other HART device (for example, a PC-Based Configurator) is used, the user must terminate the program, power cycle the transmitter, and restart the program. The user must then verify the value shown in each changed parameter.
 - When the local interface is used, the user must use the **View** menu to verify the value shown in each changed parameter.
- In order to validate the entire configuration before placing the transmitter into service, perform a proof test on the transmitter.

Startup

There are no safety-specific requirements for startup.

Preventive Maintenance

Periodic Proof Testing

The following proof tests are recommended. The simpler Partial Proof Test verifies that the milliamp output is fully functional and that no problems exist with the wiring, loop resistance, and power supply levels. The Comprehensive Proof Test also verifies the input circuitry, ensuring that the device responds to process pressure changes within the specified safety accuracy.

Partial Proof Test

The Partial Proof Test satisfies the Proof Test requirements, and will detect more than 61% of all DU failures that are not detected by the automatic diagnostics and supporting electronics.

Required tools: Either a HART Master, HART Communicator, or an optional local display module and a milliamp meter.

1. Follow the required protocol to remove the device from online operation.
2. Override the milliamp output to the High Failsafe setting of 21.0 mA.
3. Use the milliamp meter to confirm that the mA output corresponds to the entered value.
4. Override the milliamp output to the Low Failsafe setting of 3.6 mA.
5. Use the milliamp meter to confirm that the mA output corresponds to the entered value.
6. Return the device to normal operation.
7. Document the test results per the requirements of the application.

Comprehensive Proof Test

The Comprehensive Proof Test, when combined with the Partial Proof Test, satisfies the Proof Test requirements and will detect more than 89% of all DU failures that are not detected by the automatic diagnostics and supporting electronics.

Required tools: Either a HART Master, HART Communicator, or an optional local display module plus a reference milliamp meter and pressure calibration equipment.

1. Follow the required protocol to remove the device from online operation.
2. Perform a minimum two-point sensor calibration check at the 4 to 20 mA lower and upper range points (as a minimum). Refer to *Two-Point Field Calibration*, page 75.
3. Using the reference milliamp meter, verify that the milliamp output corresponds to the applied pressure within the safety accuracy.
4. Trim the calibration if necessary to match the calibration points.
5. Return the device to normal operation.
6. Document the test results per the requirements of the application.

Periodic Inspection

Other than the proof test, no periodic inspection is required.

Periodic Parts Replacement

No periodic parts replacement is required.

Firmware Updates

The firmware is not field upgradable. For firmware updates, return the transmitter to the factory. Contact Global Customer Support at 1-866-746-6477 for a return authorization and shipping instructions.

Other Preventive Maintenance

No other preventive maintenance is required.

Required Maintenance Documentation

A record of the configuration should be maintained, including the configuration password.

A maintenance log shall be kept. Each log entry shall contain:

- The cause for the maintenance activity (scheduled maintenance such as proof test, error code, other anomaly) and its date and time
- The maintenance action taken
- The personnel performing the maintenance
- The date(s) on which the maintenance was initiated and concluded

Fault Handling

How to Detect a Fault

Faults can be detected via:

- Observation
- Analog current output going to the alarm state resulting from internal diagnostics check
- Fault code being annunciated via the HART interface

Repair and Replacement

Parts replacement is generally limited to the terminal block assembly, cover o-rings, vent plug (if applicable), and optional display. A proof test must be performed after any field repair. Repair in the field at a finer level should not be attempted; the transmitter should be returned to the factory for repair. Contact Global Customer Support at 1-866-746-6477 for a return authorization and shipping instructions.

Revalidation Procedures

When returning the transmitter to service after repair or replacement, the proof test will provide validation of proper configuration and operation.

Fault Reporting Requirements

Faults should be recorded in the maintenance log and reported to Global Customer Support at 1-866-746-6477.

Demand Reporting Requirements

To verify the mode of operation, contact Global Customer Support.

Shutdown

No special procedure is necessary when removing power to the transmitter. All configuration data are retained through loss of power.

Tools

Tools Necessary for Maintenance

- PC-Based Configurator or HART Communicator. (The transmitter can be configured without one of these, but the process is considerably more involved.)
- Means to provide pressure to perform a two-point calibration check of the transmitter.
- An independent means of measuring the pressure. This means should have an accuracy at least ten times better than the safety accuracy of the transmitter.

Tools Necessary for Revalidation

- PC50 Configurator or HART Communicator. (The transmitter can also be configured with the local display, but the process is more involved.)
- Means to provide pressure to perform a two-point calibration check of the transmitter.
- An independent means of measuring the pressure. This means should be accurate to at least ten times better than the safety accuracy of the transmitter.

Procedures for Tools Maintenance

Not applicable.

Schneider Electric Systems USA, Inc.
38 Neponset Avenue
Foxboro, MA 02035
United States of America

1-866-746-6477 inside the U.S.
1-508-549-2424 outside the U.S.

pasupport.schneider-electric.com

As standards, specifications, and design change from time to time,
please ask for confirmation of the information given in this publication.

© 2018 – 2019 Schneider Electric Systems USA, Inc. All rights reserved.

MI 020-611