

I/A Series[®] Intelligent Vortex Flowmeters
84F Style B Flanged Body – Single Measurement Configuration

INTEGRALLY MOUNTED ELECTRONICS

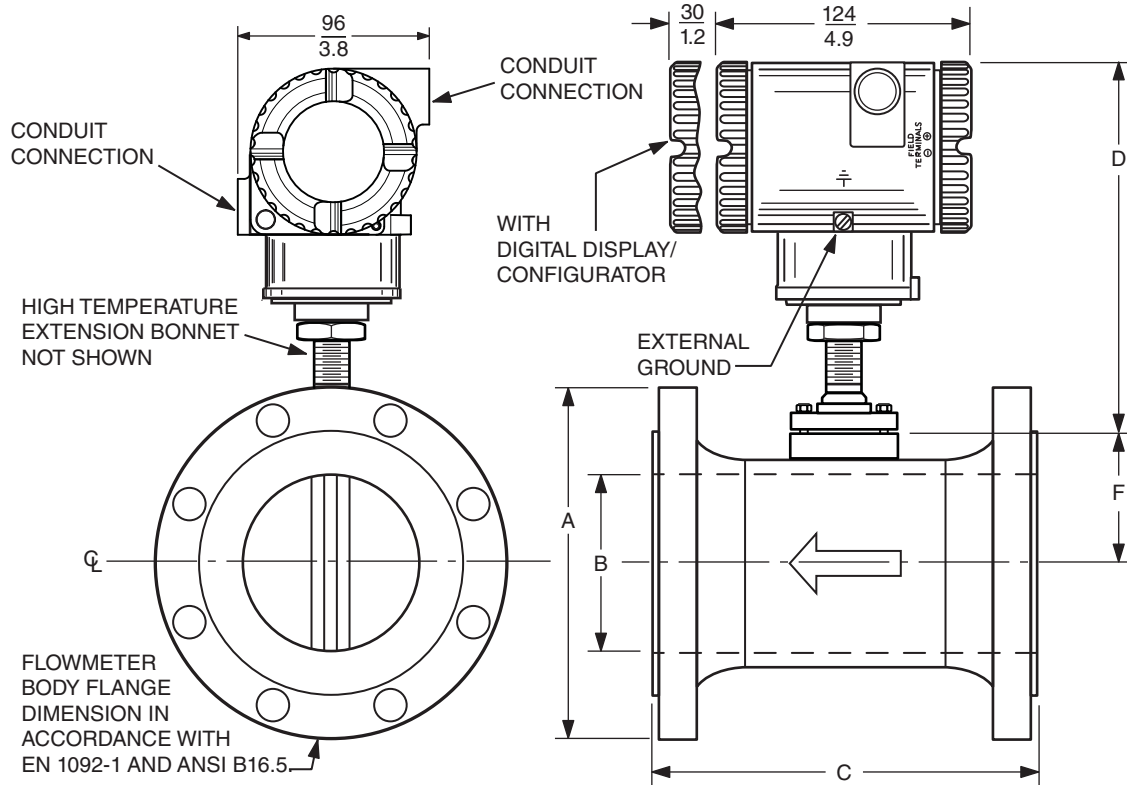

For Dimensions A, B, C, and F, refer to Table 1 through Table 4.

For Dimension D refer to page 6.

For dimensional information specific to your sales order, contact your sales representative to order a Certified Dimensional Print (CDP).

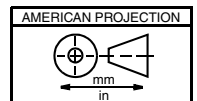

Table 1. 84F Single Measurement Configuration With ANSI Flanges and With Integral Housing Body, Flange, and Shedder Bar Material Model Code Options R, J, D, and H

Nominal Line Size	Flange Type	Dimensions in inches				
		A (O.D.)	B (I.D.)	C (a) (b) RF	C (a) (b) RTJ	F
3/4 in (a)	Class 150	3.88	0.74	6.56	--	1.82
	Class 300	4.62	0.74	6.94	7.32	1.82
	Class 600	4.62	0.74	7.44	7.44	1.82
	Class 900	5.12	0.74	8.44	8.44	1.82
	Class 1500	5.12	0.74	8.44	8.44	1.82
1 in (a)	Class 150	4.25	0.96	6.80	7.18	1.93
	Class 300	4.88	0.96	7.32	7.70	1.93
	Class 600	4.88	0.96	7.82	7.82	1.93
	Class 900	5.88	0.96	8.7	8.70	1.93
	Class 1500	5.88	0.96	8.7	8.70	1.93
1 1/2 in (a)	Class 150	4.62	1.50	7.32	7.70	2.20
	Class 300	6.12	1.50	7.82	8.20	2.20
	Class 600	6.12	1.50	8.44	8.44	2.20
	Class 900	7.00	1.50	9.44	9.44	2.20
	Class 1500	7.00	1.50	9.44	9.44	2.20
2 in (a)	Class 150	6.00	1.94	7.75	8.13	2.32
	Class 300	6.50	1.94	8.25	8.75	2.32
	Class 600	6.50	1.94	9.01	9.13	2.32
	Class 900	8.50	1.94	11.25	11.37	2.32
	Class 1500	8.50	1.69	11.25	11.37	2.20
3 in (a)	Class 150	7.50	2.87	8.88	9.26	2.75
	Class 300	8.25	2.87	9.62	10.12	2.75
	Class 600	8.25	2.87	10.38	10.50	2.75
	Class 900	9.50	2.87	11.88	12.00	2.75
	Class 1500	10.50	2.63	13.12	13.25	2.62
4 in (a)	Class 150	9.00	3.83	9.62	10.00	3.35
	Class 300	10.00	3.83	10.38	10.88	3.35
	Class 600	10.75	3.83	12.12	12.24	3.35
	Class 900	11.50	3.83	13.12	13.24	3.35
	Class 1500	12.25	3.44	13.88	14.00	3.35
6 in (a)	Class 150	11.00	5.76	12.00	12.38	4.42
	Class 300	12.50	5.76	12.76	13.26	4.42
	Class 600	14.00	5.76	14.74	14.86	4.42
	Class 900	15.00	5.19	16.5	16.62	4.42
	Class 1500	15.50	5.19	19.00	19.25	4.42
8 in (a)	Class 150	13.50	7.63	15.00	15.38	5.47
	Class 300	15.00	7.63	15.75	16.26	5.47
	Class 600	16.50	7.63	18.00	18.12	5.47
	Class 900	18.50	6.81	20.26	20.38	5.47
	Class 1500	19.00	6.81	24.26	24.64	5.47
10 in (a)	Class 150	16.00	9.56	15.00	15.38	6.55
	Class 300	17.50	9.56	16.24	16.74	6.55
	Class 600	20.00	9.56	19.5	19.62	6.55
12 in (b)	Class 150	19.00	11.37	17.00	17.38	7.55
	Class 300	20.50	11.37	18.24	18.74	7.55
	Class 600	22.00	11.37	20.74	20.76	7.55

a. For 3/4 inch through 10 inch nominal line sizes, the overall length "C" is ±0.250 in (±6.4 mm).

b. For 12 inch nominal line sizes, the overall length "C" is ±0.350 in (±8.9 mm).

Table 2. 84F Single Measurement Configuration With Metric Flanges and With Integral Housing Body, Flange, and Shedder Bar Material Model Code Options R, J, D, and H

Nominal Line Size	Flange Type	Dimensions in mm			
		A (O.D.)	B (I.D.)	C (a) (c)	F
15 mm (a)	PN 40 (b)	95.00	18.80	138.00	46.20
	PN 100	105.00	18.80	152.00	46.20
25 mm (a)	PN 40 (b)	115.00	24.31	142.00	49.00
	PN 100	140.00	24.31	178.00	49.00
	PN 160	140.00	24.31	178.00	49.00
40 mm (a)	PN 40 (b)	150.00	38.10	152.00	55.90
	PN 100	170.00	38.10	186.00	55.90
	PN 160	170.00	38.10	190.00	55.90
50 mm (a)	PN 40 (b)	165.00	49.20	166.00	58.90
	PN 63	180.00	49.20	194.00	58.90
	PN 100	195.00	49.20	206.00	58.90
	PN 160	195.00	49.20	220.00	58.90
80 mm (a)	PN 40 (b)	200.00	72.90	202.00	69.90
	PN 63	215.00	72.90	230.00	69.90
	PN 100	230.00	72.90	242.00	69.90
	PN 160	230.00	72.90	258.00	69.90
100 mm (a)	PN 40 (b)	235.00	97.18	222.00	85.10
	PN 63	250.00	97.18	248.00	85.10
	PN 100	265.00	97.18	272.00	85.10
	PN 160	265.00	97.18	292.00	85.10
150 mm (a)	PN 16	285.00	146.30	237.00	112.30
	PN 40 (b)	300.00	146.30	277.00	112.30
	PN 63	345.00	146.30	317.00	112.30
	PN 100	355.00	146.30	357.00	112.30
	PN 160	355.00	146.30	383.00	112.30
200 mm (a)	PN 16	340.00	193.68	302.00	138.90
	PN 25	360.00	193.68	338.00	138.90
	PN 40	375.00	193.68	354.00	138.90
	PN 63	415.00	193.68	398.00	138.90
	PN 100	430.00	193.68	438.00	138.90
	PN 160	430.00	173.05	458.00	138.90
250 mm (a)	PN 16	405.00	242.87	318.00	166.40
	PN 25	425.00	242.87	354.00	166.40
	PN 40	450.00	242.87	388.00	166.40
	PN 63	470.00	242.87	428.00	166.40
	PN 100	505.00	242.87	492.00	166.40
300 mm (c)	PN 16	460.00	288.90	359.00	191.80
	PN 25	485.00	288.90	387.00	191.80
	PN 40	515.00	288.90	433.00	191.80
	PN 63	530.00	288.90	483.00	191.80
	PN 100	585.00	288.90	543.00	191.80

- a. For 15 mm through 250 mm nominal line sizes, the overall length "C" is ± 6.4 mm (± 0.250 in).
- b. May be used with PN 25 mating flange.
- c. For 300 mm nominal line sizes, the overall length "C" is ± 8.9 mm (± 0.350 in).

Table 3. 84F Single Measurement Configuration With ANSI Flanges and With Integral Housing Body, Flange, and Shedder Bar Material Model Code Option Y (Backward Compatible with Style A)

(Note: These versions should only be used when replacing a style A length meter or stocking purposes for style A length meters)

Nominal Line Size	Flange Rating	Dimensions in inches			
		A (O.D.)	B (I.D.)	C (a)	F
3/4 in	Class 150	3.88	0.74	6.00	1.82
	Class 300	4.62	0.74	6.00	
	Class 600	4.62	0.74	6.50	
1 in	Class 150	4.25	0.96	6.50	1.93
	Class 300	4.88	0.96	6.50	
	Class 600	4.88	0.96	7.00	
1 1/2 in	Class 150	4.62	1.50	7.25	2.20
	Class 300	6.12	1.50	7.25	
	Class 600	6.12	1.50	7.88	
2 in	Class 150	6.00	1.94	7.75	2.32
	Class 300	6.50	1.94	7.75	
	Class 600	6.50	1.94	8.50	
3 in	Class 150	7.50	2.87	8.75	2.75
	Class 300	8.25	2.87	8.75	
	Class 600	8.25	2.87	9.50	
4 in	Class 150	9.00	3.83	9.50	3.35
	Class 300	10.00	3.83	9.50	
	Class 600	10.75	3.83	10.50	
6 in	Class 150	11.00	5.76	12.00	4.42
	Class 300	12.50	5.76	12.75	
	Class 600	14.00	5.76	14.75	
8 in	Class 150	13.50	7.63	15.00	5.47
	Class 300	15.00	7.63	15.75	
	Class 600	16.50	7.63	18.00	
10 in	Class 150	16.00	9.56	15.00	6.55
	Class 300	17.50	9.56	16.20	
12 in	Class 150	19.00	11.37	17.00	7.55
	Class 300	20.50	11.37	18.20	

a. Overall length "C" is ±0.250 in (±6.4 mm).

NOTE: Style B Vortex flowmeters with ANSI flanges contain a model code option for face-to-face lengths that are backward compatible with Style A Vortex flowmeters. Style B model code selection "Y" matches Style A model code selection "S". The majority of Style B DIN flanges have shorter face-to-face lengths than Style A. Contact Global Customer Support for backward compatibility of DIN face-to-face lengths.

Table 4. 84F Style A Face-to-Face Lengths for DIN Flanges

(Note: These versions should only be used when replacing a style A length meter or stocking purposes for style A length meters)					
Nominal Line Size	Flange Type	Dimensions in mm			
		A (O.D.)	B (I.D.)	C (b)	F
15 mm	PN 40 (a)	95.00	18.80	152.00	46.20
	PN 100	105.00	18.80	160.00	46.20
25 mm	PN 40 ^a	115.00	24.31	166.00	49.00
	PN 100	140.00	24.31	178.00	49.00
40 mm	PN 40 ^a	150.00	38.10	179.00	55.90
	PN 100	170.00	38.10	199.00	55.90
50 mm	PN 40 ^a	165.00	49.20	193.00	58.90
	PN 63	180.00	49.20	202.00	58.90
	PN 100	195.00	49.20	211.00	58.90
80 mm	PN 40 ^a	200.00	72.90	220.00	69.90
	PN 63	215.00	72.90	230.00	69.90
	PN 100	230.00	72.90	242.00	69.90
100 mm	PN 40 ^a	235.00	97.18	240.00	85.10
	PN 63	250.00	97.18	250.00	85.10
	PN 100	265.00	97.18	268.00	85.10
150 mm	PN 16	285.00	146.30	305.00	112.30
	PN 40 ^a	300.00	146.30	320.00	112.30
	PN 63	345.00	146.30	360.00	112.30
	PN 100	355.00	146.30	360.00	112.30
200 mm	PN 16	340.00	193.68	351.00	138.90
	PN 40	375.00	193.68	396.00	138.90
	PN 63	415.00	193.68	443.00	138.90
	PN 100	430.00	193.68	443.00	138.90
250 mm	PN 16	405.00	242.87	316.00	166.40
	PN 40	450.00	242.87	408.00	166.40
	PN 63	470.00	242.87	481.00	166.40
300 mm	PN 16	460.00	288.90	358.00	191.80
	PN 40	515.00	288.90	461.00	191.80
	PN 63	530.00	288.90	513.00	191.80

- a. May be used with PN 25 mating flange.
b. Overall length "C" is ± 6.4 mm (± 0.250 in).

“D” Dimensions

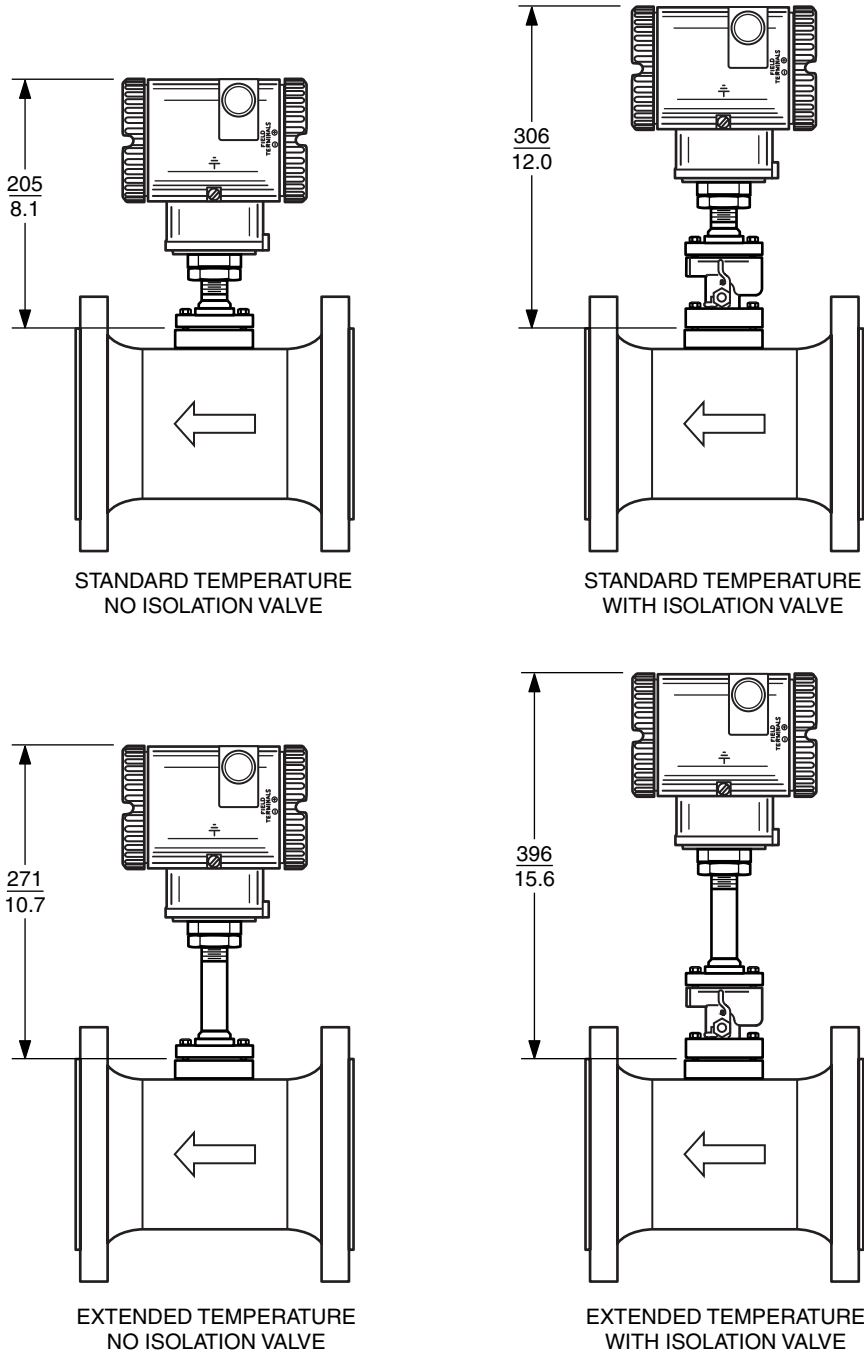

Remotely Mounted Electronics Housing

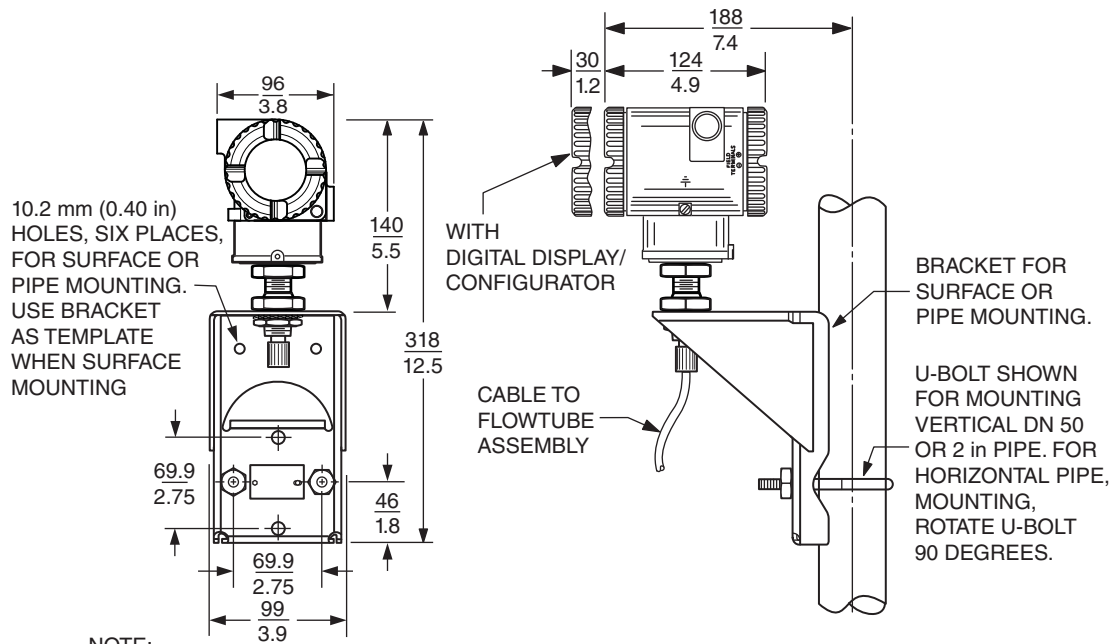

NOTE:

WHEN THE BRACKET IS USED FOR WALL MOUNTING, REPLACE U-BOLT WITH TWO (OR FOUR IF NECESSARY) 0.375 IN BOLTS OF SUFFICIENT LENGTH TO PASS THROUGH THE BRACKET AND SURFACE

84F Flowmeter Body With Integral Junction Box and Remotely Mounted Electronics

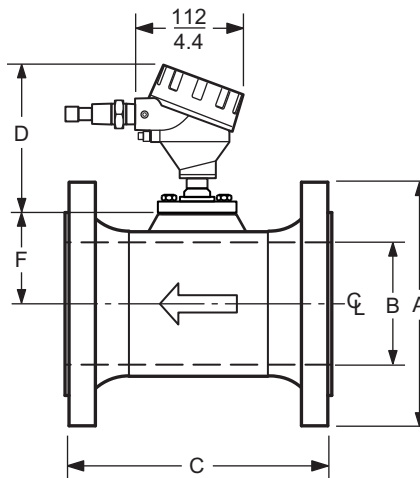

For Dimensions A, B, C, and F, refer to Table 1 through Table 4.
For Dimension D, refer to page 8.

“D” Dimensions

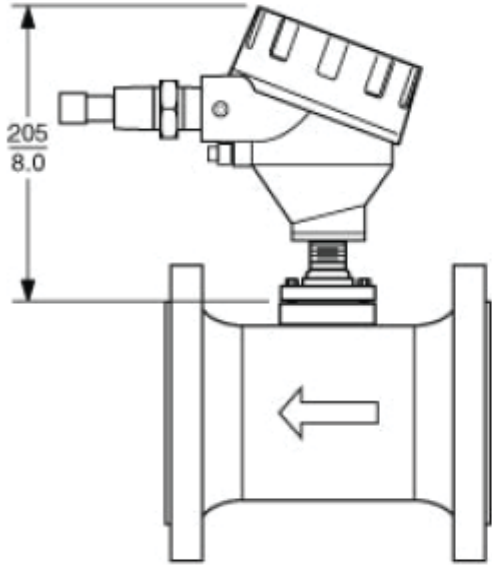

STANDARD TEMPERATURE
NO ISOLATION VALVE

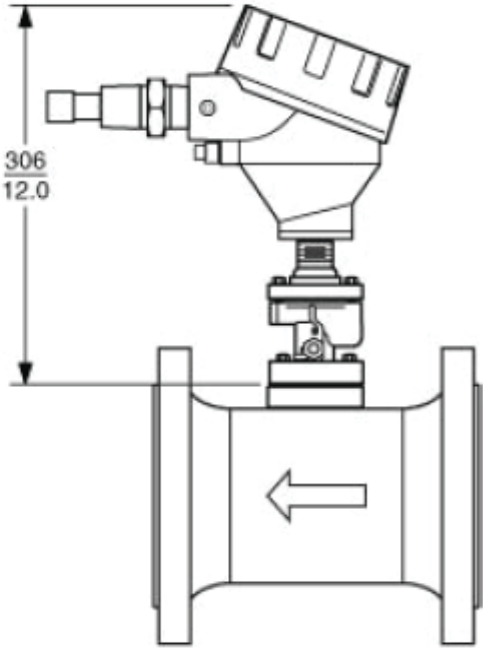

STANDARD TEMPERATURE
WITH ISOLATION VALVE

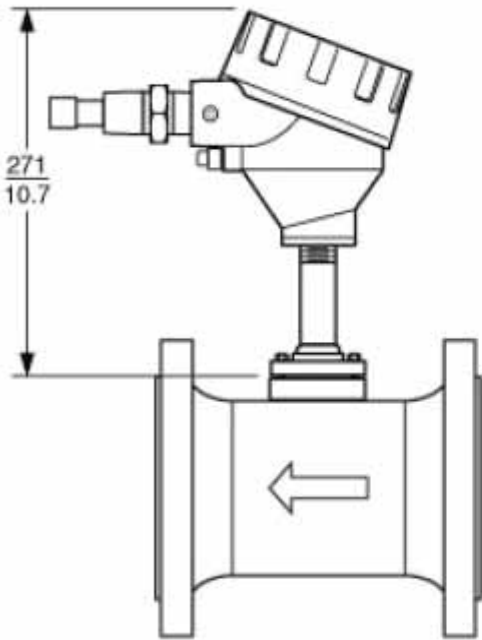

EXTENDED TEMPERATURE
NO ISOLATION VALVE

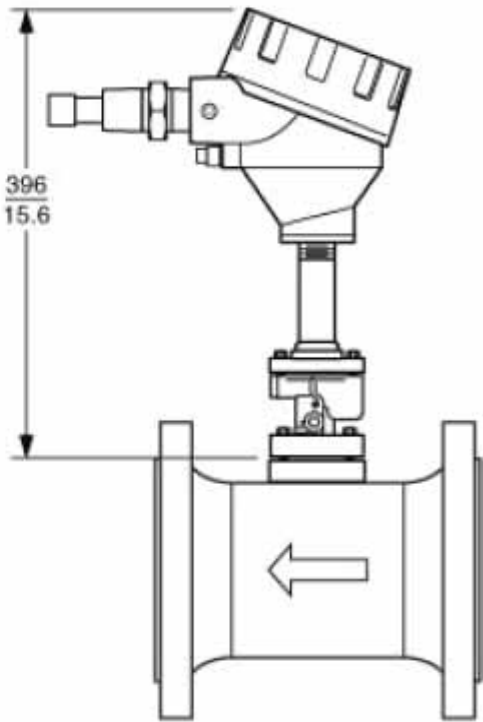

EXTENDED TEMPERATURE
WITH ISOLATION VALVE

Schneider Electric Systems USA, Inc.
38 Neponset Avenue
Foxboro, MA 02035
United States of America
<http://www.schneider-electric.com>

Global Customer Support
Inside U.S.: 1-866-746-6477
Outside U.S.: 1-508-549-2424
<https://pasupport.schneider-electric.com>

Copyright 2011-2018 Schneider Electric Systems USA, Inc. All rights reserved.

Schneider Electric, Foxboro, and I/A Series are trademarks of Schneider Electric Systems USA, Inc., its subsidiaries, and affiliates. All other trademarks are the property of their respective owners.

Life Is n

Foxboro[®]

by **Schneider** Electric