

# SRI990 Analog Positioner

These instructions are to be used as a guide for quick start-up. For more detailed information please refer to the standard documents "Master Instructions" and "Product Specification Sheet". These can be found on our Website [www.foxboro-eckardt.com](http://www.foxboro-eckardt.com).

## 1. Mounting to actuators

During operation the flat side of the spindle **9** on the back of the positioner must **always** point towards the arrow **26**. The working angle around this position is  $\pm 45^\circ$

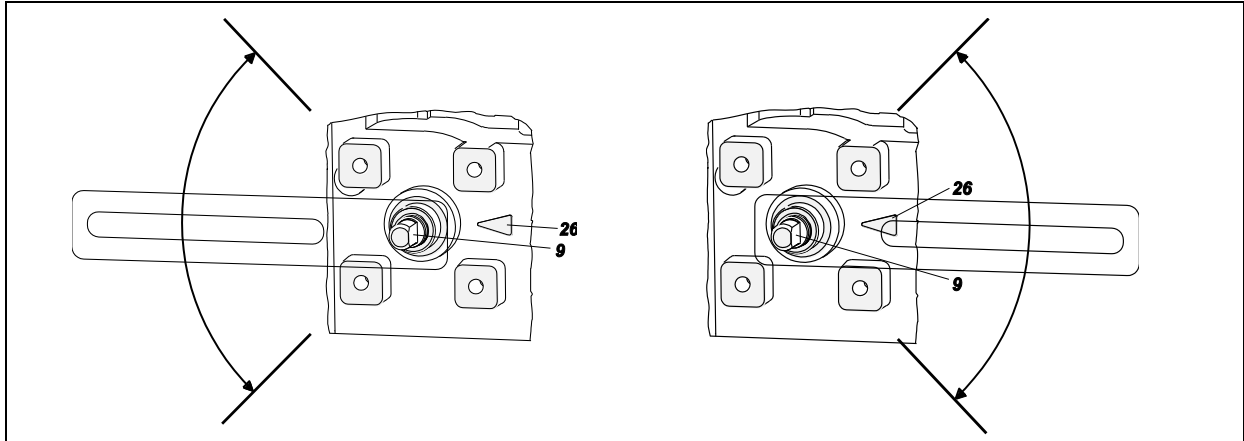

### 1.1 Mounting to linear actuators

NAMUR mounting  
- left hand -

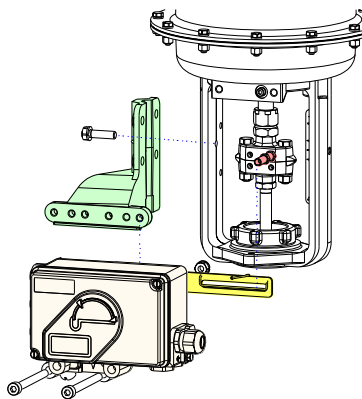

Direct mounting

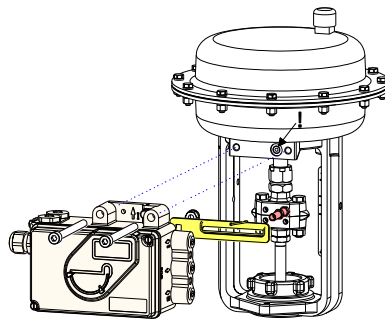

NAMUR mounting  
- right hand -

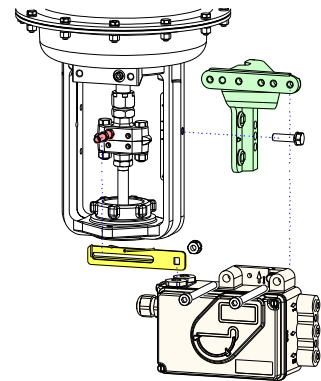

#### Feedback lever for linear actuators:

The carrier bolt **B** is in the slot of the feedback lever **A** and the compensating spring **F** touches the carrier bolt.

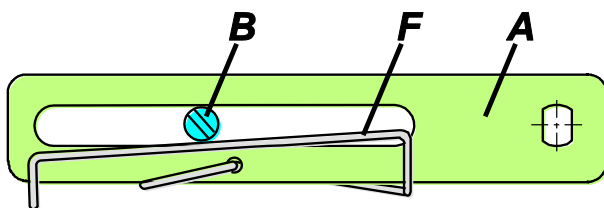

#### Carrier bolt **B**:

- 1 threaded sleeve
- 2 Stud
- 3 coupling piece

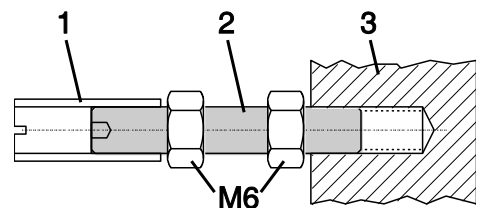

## 1.2 Mounting to rotary actuators

- Do not tighten grub screw **4** against the thread of spindle **9**!
- When in use the flat side of the spindle **9** must move ( 0 ↔ 100%) in front of the arrow **26**.
- When the product temperature rises, the drive shaft **1** increases in length. Therefore, the rotary adaptor **3** must be mounted so that approx. 1 mm (0.04 in.) of clearance results between the drive shaft **1** and the rotary adaptor **3**. This is achieved by placing an appropriate number of washers **5**, on the feedback spindle **9**, before attaching the rotary adaptor.

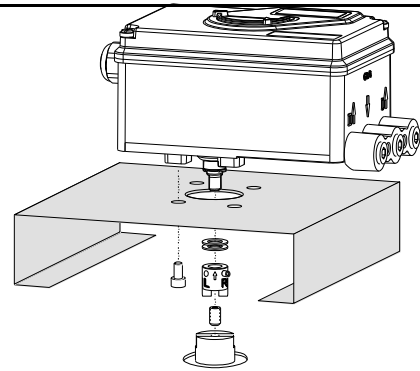

Actuator, left turning

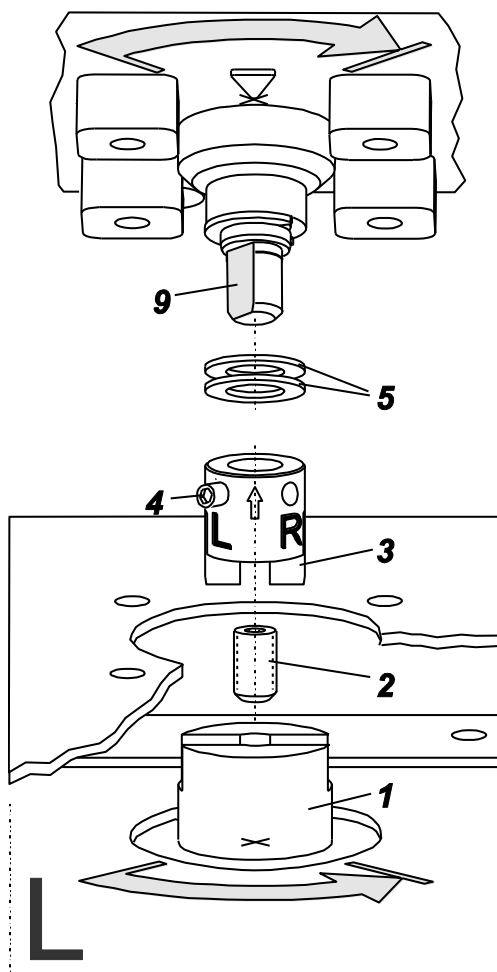

Actuator, right turning

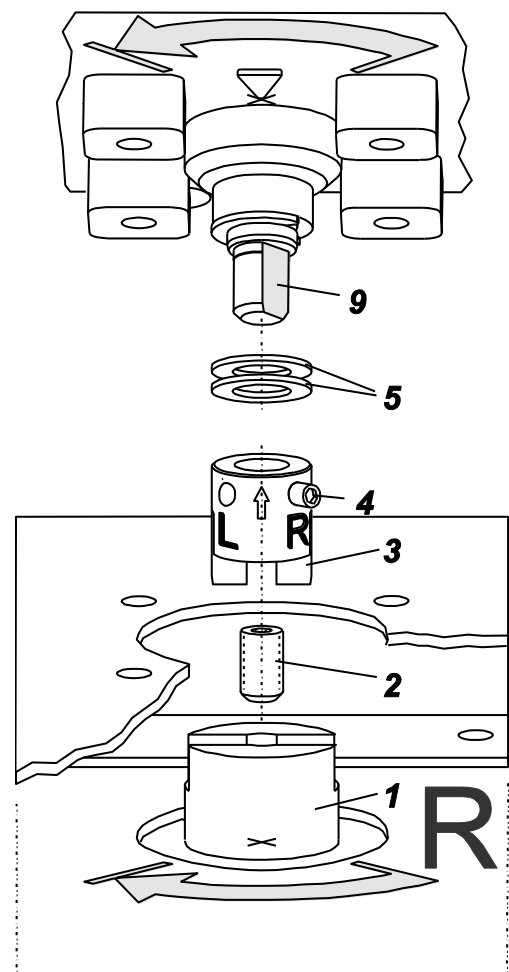

## 2 Pneumatic connections

Air supply (s): 1,4 to 6 bar (but not more than the max. pressure of actuator), free of oil, dust and water !

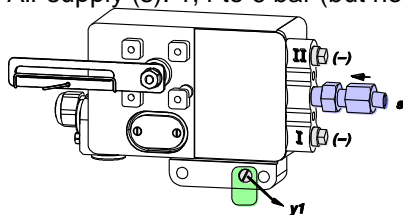

Single acting, direct mounting  
s air supply y1, y2 pneumatic outputs (--) closed

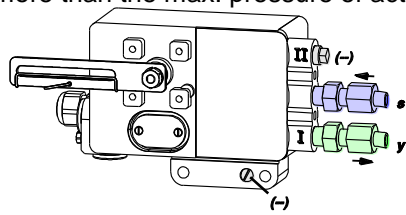

Single acting

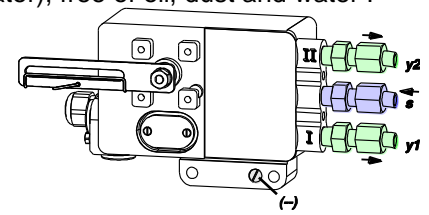

Double acting

### 3. Electrical connections

The safety requirements of document EX EVE0001 as well as the requirements of PSS EVE0107 and MI EVE0107 for SRI990 must be observed!

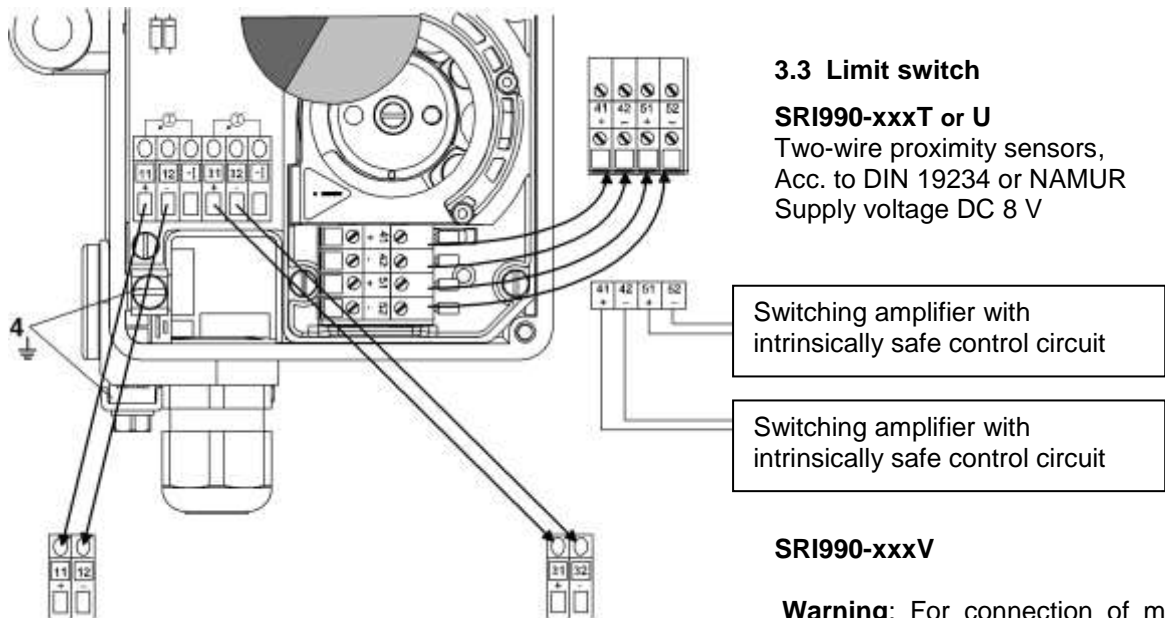

#### 3.1 Setpoint

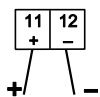

Input 4 to 20 mA

#### 3.2 Position feedback 4-20 mA (SRI990-xxQ)



Analog output 4 to 20 mA,  
Two-wire system,  
Supply voltage DC 8 to 48 V\*

#### 3.3 Limit switch

##### SRI990-xxxT or U

Two-wire proximity sensors,  
Acc. to DIN 19234 or NAMUR  
Supply voltage DC 8 V

Switching amplifier with  
intrinsically safe control circuit

Switching amplifier with  
intrinsically safe control circuit

##### SRI990-xxxV

**Warning:** For connection of micro switches please refer to MI (Master Instruction) and respect the safety requirements described in document EX EVE0001.

### 4 START UP (setting by means of local switches and potentiometers)

#### 4.1 Initial setting

After mounting the positioner on the actuator, air and electrical input connected, proceed as follow.

First all switches must be in position I. This is the setting for Input signal "4 to 20 mA" and "Left mounted" (counter clockwise rotation).

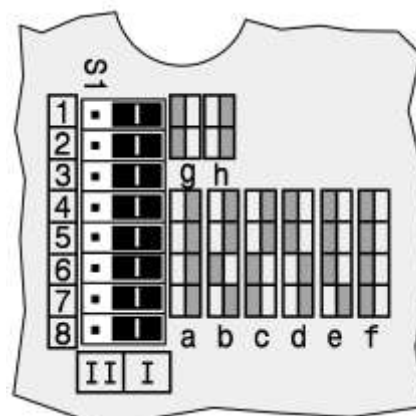

\* For intrinsically safe circuits please refer to certificate / data label for max. operating voltages etc.

**4.2 Configuration direction of rotation of feedback shaft**

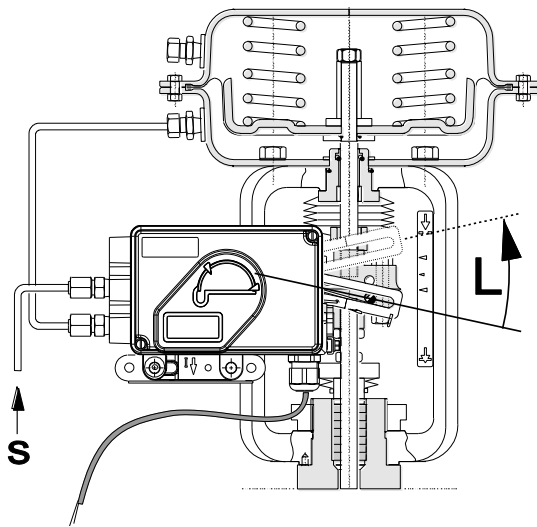

Defined as direction of rotation of feedback shaft from the start to the end position, looking at the positioner from the front. Switch 1+2 to "R" if necessary.

R= right turn (clockwise) L= left turn (counter cw)

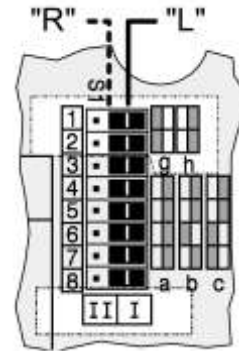

**4.3 Setting of zero, span and gain**

- a) Apply 4 mA to Input.
- b) Turn potentiometer P3 for zero point (ZERO) until actuator just begins to move from its end position.  
Rotation P3 to the right: zero point is increased  
Rotation P3 to the left: zero point is reduced
- c) Apply 20 mA to Input
- d) Turn potentiometer P2 for span (S) until actuator exactly reaches its end position.  
Rotation P2 to the right: span is increased  
Rotation P2 to the left: span is reduced
- e) The loop amplification of the positioner is set via potentiometer P4. Trim the gain so that the actuator will not swing at constant given input value.
- f) Re-check zero and span settings.

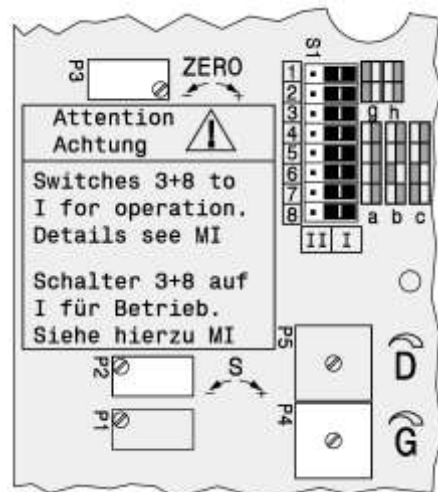

**5 Setting and Start Up of position transmitter 4-20mA**

The electronic connection of the position transmitter must be assured. Both LED's are then light up.

**Adjusting the start of the measuring range (4mA)**

- a) Move the actuator to the starting position.
- b) Press push button S1 „Config Output 4mA“ longer than 2 seconds. During this time LED 1 lights up. After 2 seconds both LED's are light up again, the value for 4mA is stored.

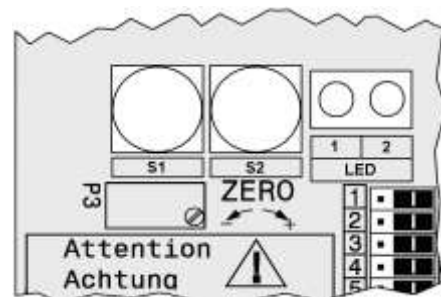

**Adjusting the end of the measuring range (20mA)**

- a) Move the actuator to the end position.
- b) Press push button S2 „Config Output 20mA“ longer than 2 seconds. During this time LED 2 lights up. After 2 seconds both LED's are light up again, the value for 20mA is stored.