

## SRI986 Electro-Pneumatic Positioner

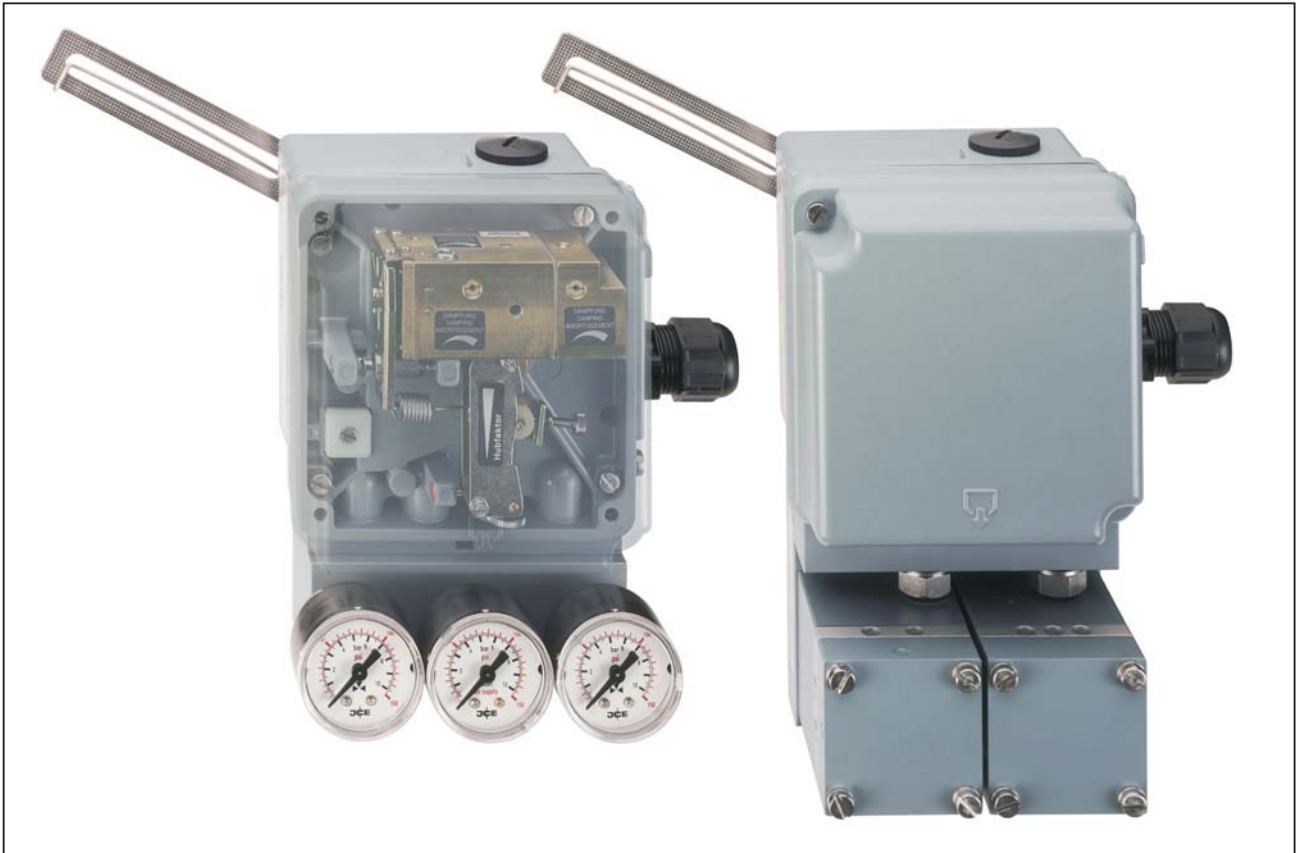

The SRI986 Positioner is for operation of pneumatic valve actuators from control systems and electrical controllers with electric control signals. It is used to reduce the adverse effects of valve friction, for higher thrust and shorter positioning time.

### FEATURES

- Independent adjustment of stroke range and zero
- Adjustable amplification and damping
- Split range up to 3-fold possible
- One version for 0 to 20 mA and 4 to 20 mA input
- Supply pressure up to 6 bar (90 psig)
- Low vibration effect in all directions
- Mounting according to IEC 534, part 6 (NAMUR)
- Rotation adapter for angles up to 120°
- Explosion protection:
  - II 2 G EEx ib/ia IIB/IIC T4/T6 according ATEX or intrinsically safe according to FM and CSA
- EMC in accordance with international standards and laws (CE)
- Modular system of additional equipment
  - Limit switches
  - Position transmitter
  - Booster
  - Connection manifold

CONTENTS	PAGE
1 GENERAL . . . . .	3
FUNCTION . . . . .	4
ADDITIONAL EQUIPMENT . . . . .	5
2 MOUNTING . . . . .	6
2.1 Dimensions . . . . .	6
2.2 Mounting to diaphragm actuators according to JEC 534-6 . . . . .	8
2.3 Mounting to rotary actuators . . . . .	10
3 ELECTRICAL CONNECTIONS . . . . .	14
4 START-UP . . . . .	14
4.1 Setting boost . . . . .	14
4.2 Setting zero point and stroke . . . . .	15
4.3 Setting damping . . . . .	15
4.4 Subdivision of input range (Split-range) . . . . .	16
4.5 Determination of rotation angle $U_{\phi}$ . . . . .	16
4.6 Determination of stroke factor $U_x$ . . . . .	16
4.6.1 Stroke factor ranges of range springs . . . . .	17
4.6.2 Characteristics of range springs . . . . .	17
5 MAINTENANCE . . . . .	18
5.1 Basic adjustment of single-acting positioner (pneumatic part) . . . . .	18
5.2 Basic adjustment of double-acting positioner (pneumatic part) . . . . .	19
5.3 Checking and adjusting the I-p converter . . . . .	20
5.4 Cleaning throttles . . . . .	22
6 BOOSTER REPLACEMENT . . . . .	22
7 SAFETY REQUIREMENTS . . . . .	22
8 OPTION "LIMIT SWITCH" . . . . .	23
9 OPTION "POSITION TRANSMITTER" . . . . .	26
9.5 Setting and Start Up of position transmitter 4 - 20 mA . . . . .	27
10 SAFETY REQUIREMENTS FOR OPTIONS . . . . .	29
11 TROUBLESHOOTING . . . . .	30
Photographs . . . . .	31

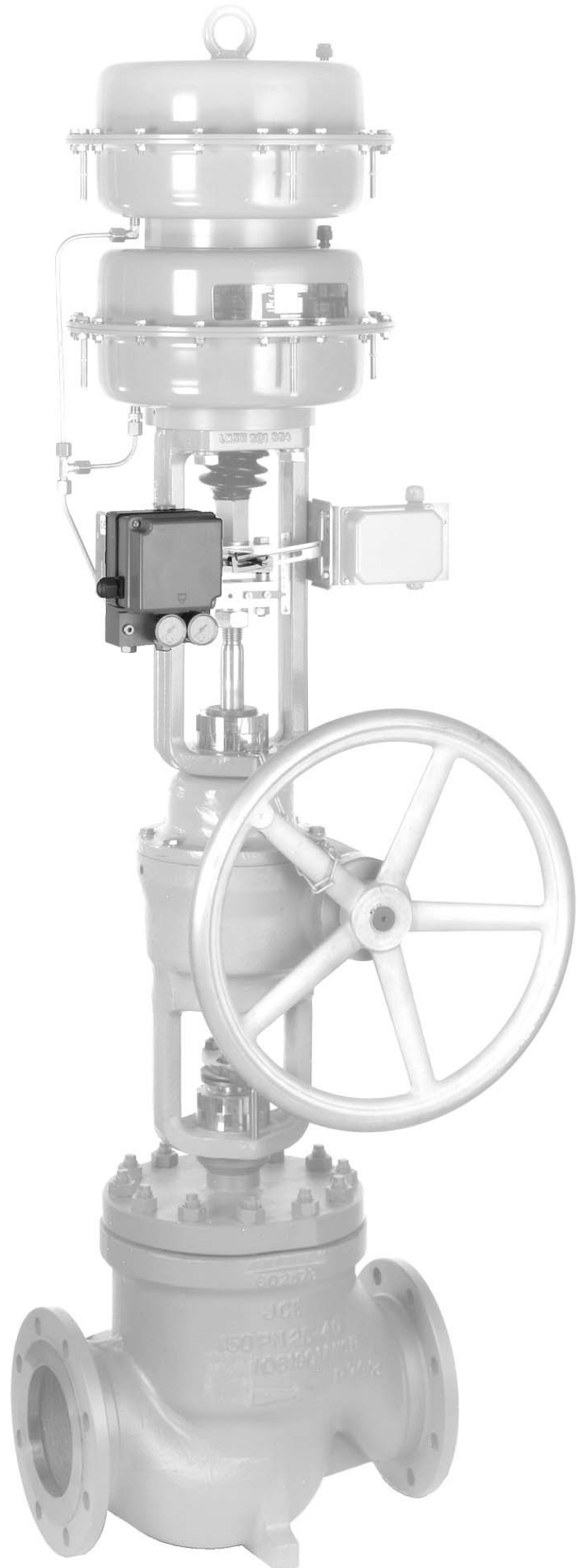

**1 GENERAL**

The electro-pneumatic positioner is used for direct operation of pneumatic valve actuators by means of electrical controllers or control systems with an analog output signal of 0 to 20 mA or 4 to 20 mA or split ranges. Positioner and pneumatic actuator form a control loop with the command variable  $w_s$  (output signal  $y$  of the master controller), the correcting variable  $y_s$  and the stroke position  $x_s$  of the actuator. In this manner disturbing influences such as gland friction and medium forces within the valve are compensated by the positioner.

In addition, the positioning force of the actuator can significantly be increased by an output pressure of max. 6 bar.

The electro-pneumatic positioner can be mounted on both diaphragm actuators and rotary actuators. For spring loaded actuators a single-acting positioner is used, whilst for actuators without spring loading a double-acting positioner is used. The double-acting positioner operates with two opposing control pressures.

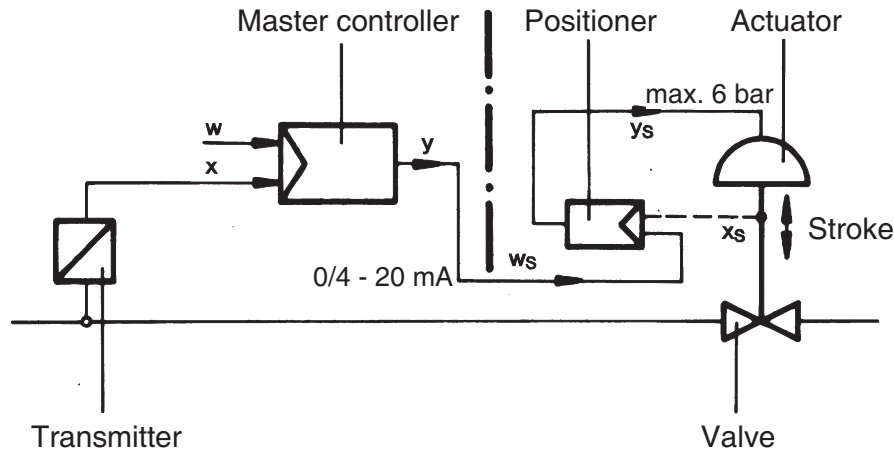
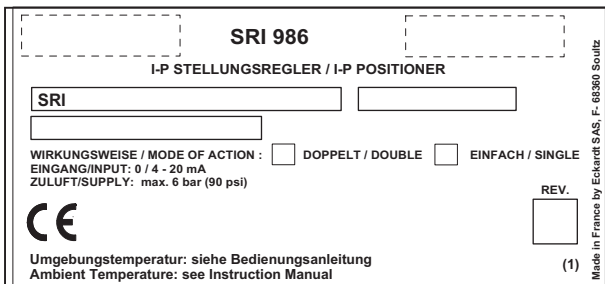

Fig. 1: Control circuit with single-acting positioner

**Identification**

The nameplate of the positioner is located at the side wall of the housing. Nameplates are in accordance with selected model. Examples:

Version without explosion protection



Version EEx ib IIC T6

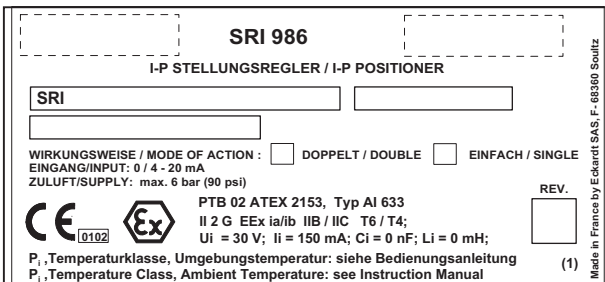

Version FM/CSA

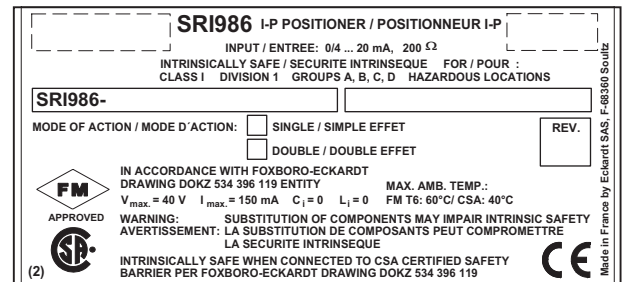

## FUNCTION

The positioner operates according to the force comparison principle:

The input current signal  $w$  flows through moving coil **51**, which is located in the field of a permanent magnet **52**. The resultant force exerts a torque on the balance arm **53**.

This leads to a change in the distance between nozzle **54** and cone **55** which results in a change in the back pressure at the nozzle. The Venturi **56**, which is supplied with air, converts the back pressure into the pressure signal  $w'$  which is fed to the compensator **57**.

An equilibrium of forces is set at balance arm **53** if the torque produced by moving coil **51** is equal to the torque reaction produced by compensator **57**.

At the same time the pressure signal  $w'$  is passed to the input diaphragm **58**. The stroke of the input diaphragm is transferred to the flapper lever **40**. The resultant change in the distance between the nozzle **59** and the flapper **60** alters the back pressure at the nozzle. This pressure acts in a single-acting positioner on an amplifier **61**. Its output pressure  $y$  results in a stroke movement of diaphragm actuator with spring resetting (see Fig. 2).

In the double-acting positioner this pressure acts on a double-acting amplifier **62**, where opposed output pressures  $y_1$  and  $y_2$  cause a stroke movement in the diaphragm actuator without spring resetting (see Fig. 3).

The stroke movement is tapped at the actuator spindle **63** of the feedback lever **11** and transferred to the stroke factor lever **17**.

The stroke factor lever **17** and the flapper lever **40** are connected by the range spring **43**.

Equilibrium of forces is set at the flapper lever **40** if the torque produced at the input diaphragm **58** is equal to the torque reaction of the range spring **43** produced by the stroke setting. Thus an actuator setting proportional to the signal input is retained constantly.

A dynamic adaption to the actuator (sensitivity, stability) can be accomplished by the throttling screw **44** and the damping throttles **46**, **47** and **48** in the double-acting positioner, the stroke range and zero point are set via the zero screw **41** and the stroke factor screw **42**.

A rising or falling actuator pressure at rising input signal is set in the single-acting positioner by means of the changeover plate **13**.

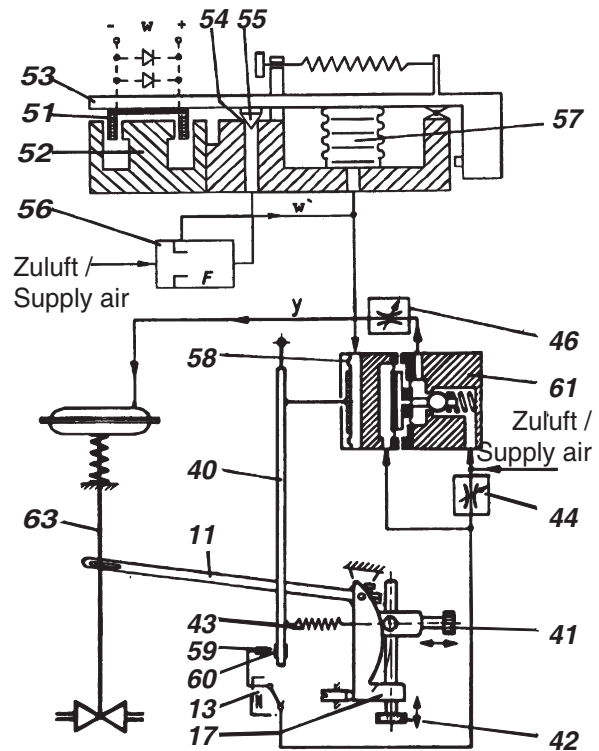

Fig. 2: Single-acting electro-pneumatic positioner

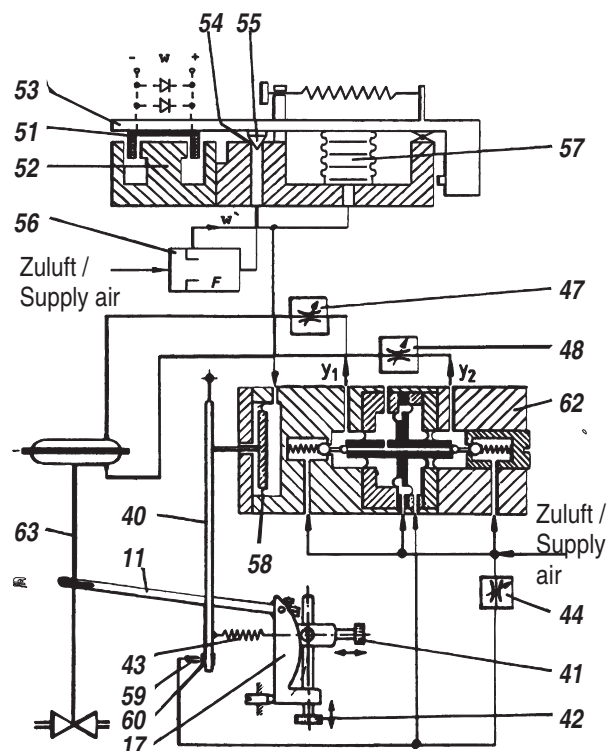

Fig. 3: Double-acting electro-pneumatic positioner

## ADDITIONAL EQUIPMENT

The air output capacity can be significantly increased, and the positioning time shortened to 1/4 or 1/7, by means of an additional single-acting or double-acting volume booster.



Fig. 4: Single-acting positioner with volume booster

If 1/4-NPT connections are desired, the connection manifolds Code LEXG-BN, -CN must be used. The connection manifold **2** Code LEXG-CN is required for piping up to 10 mm Ø, the connection manifold **3** Code LEXG-BN for up to 12 mm Ø.



Fig. 5: Connection manifolds

If an indication of actuating pressure and supply air pressure is desired for single-acting and double-acting positioners, a connection manifold with gauges (Code LEXG-JN, -MN, -RN) can be used.



Fig. 6: Connection manifold with gauges

By means of a total of five range springs the positioner can be matched to nearly all operating situations, such as up to 4-way (or with 4 to 20 mA up to 3-way) range subdivision, very high and very short strokes and angles of rotation or special cams. A standard range spring FES 628/1 is installed. Other range springs are available (see page 16)

For attachment to rotary actuators and rotary armatures an attachment-kit for rotary movement (Code EBZG-PN, -NN, -JN, -ZN) is required.

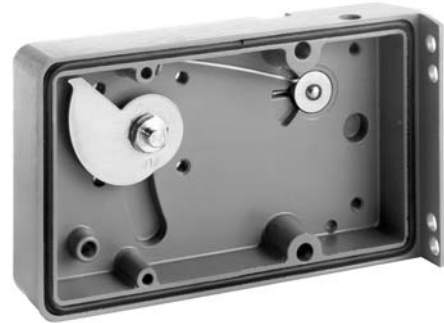

Fig. 7: Housing of the attachment kit for rotary movement

The inductive limit switch assembly (Code P, Q, R, T, V, see page 23) enables position signaling, e.g. end position signaling.



Fig. 8: Positioner with inductive limit switch assembly

The electrical position transmitter assembly (Code E or F, see page 26) converts the stroke or angle of rotation into an electrical standard signal 4 to 20 mA.

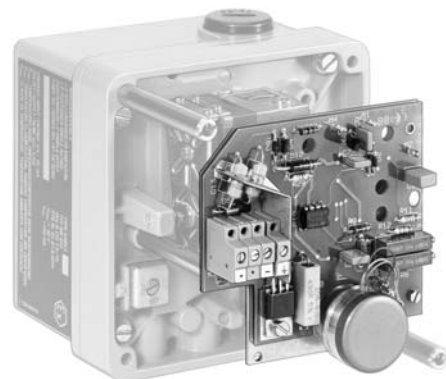

Fig. 9: Positioner with electrical position transmitter assembly



## 2 MOUNTING

### 2.1 Dimensions

#### 2.1.1 Positioner

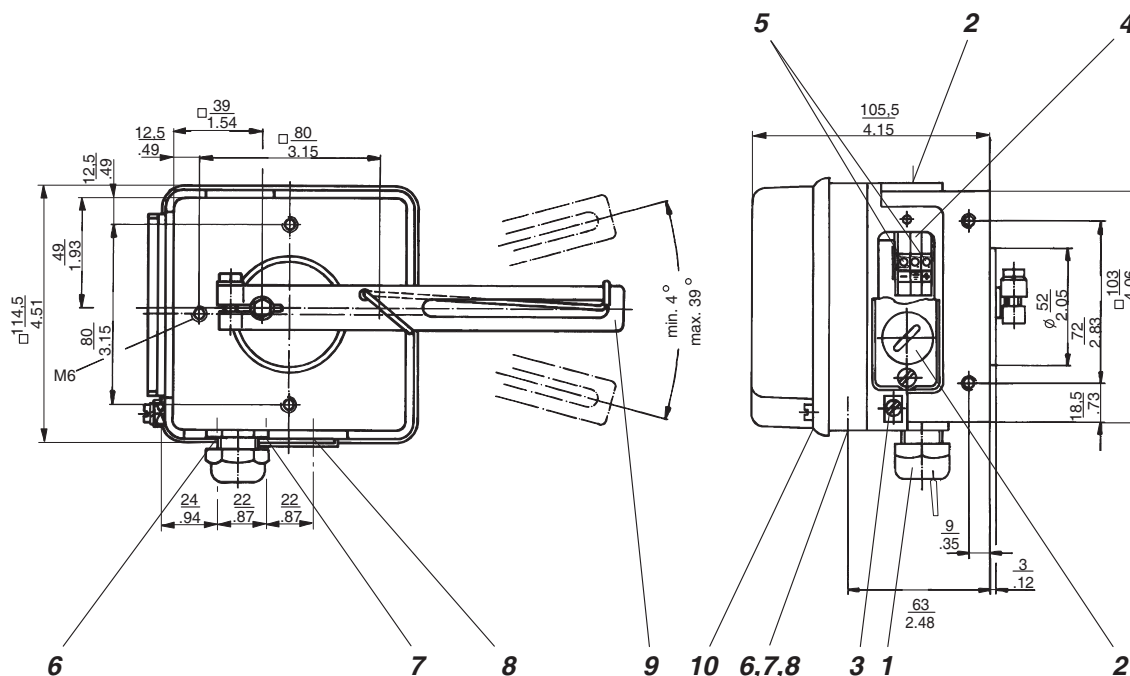

- 1 Screwed gland Pg 13.5 (line entry)
- 2 Dummy plug. Can be replaced with 1
- 3 Earth connection
- 4 Earth connection
- 5 Terminals (+/-) for signal input (w)

- 6 Internal thread G  $\frac{1}{8}$  for output II (y2)  
(only on double-acting positioners)
- 7 Internal thread G  $\frac{1}{8}$  for supply air
- 8 Internal thread G  $\frac{1}{8}$  for output I (y1)
- 9 Feedback lever
- 10 Housing cover  
Screw on the housing cover in such a way that the air vent of the attached device faces downwards !

I Ø = Correcting variable 1 (Output)  
 U = Supply air  
 II Ø = Correcting variable 2 (Output)  
 (only on double-acting positioners)

#### 2.1.2 Booster, single-acting; Code VKXG-FN

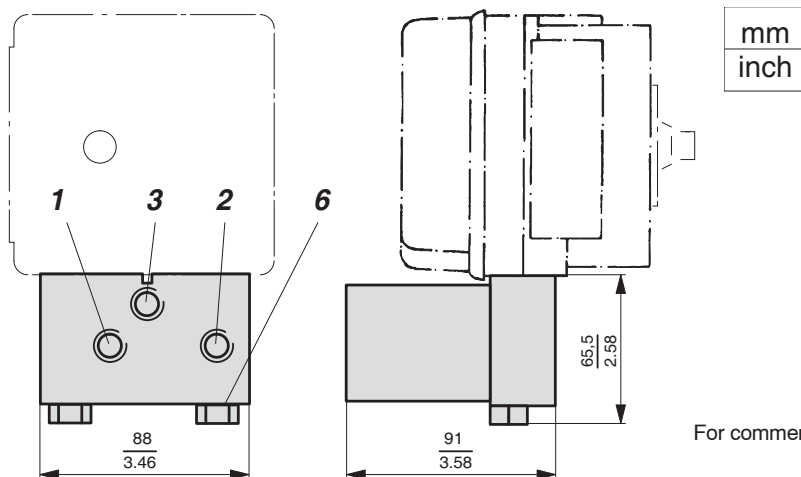

For comments see opposite sheet.

### 2.1.3 Booster single-acting with increased air output; Code VKXG-HN

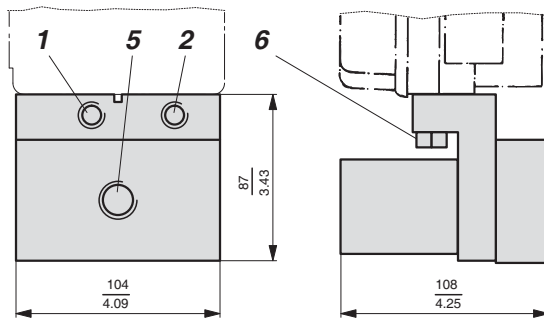

### 2.1.4 Booster double-acting Code VKXG-GN

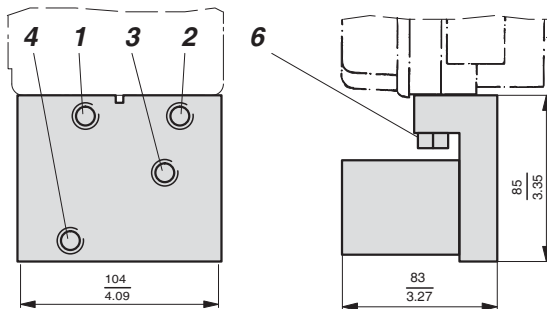

### 2.1.5 Connection manifold Code LEXG-BN

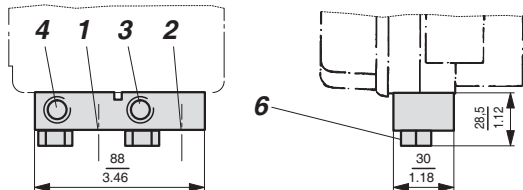

### 2.1.6 Connection manifold Code LEXG-CN

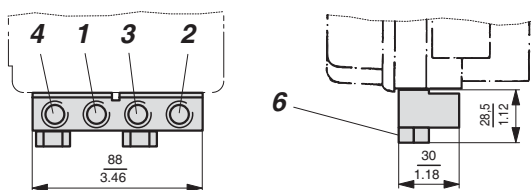

### 2.1.7 Connection manifold with gauges Code LEXG-JN, -MN, -RN

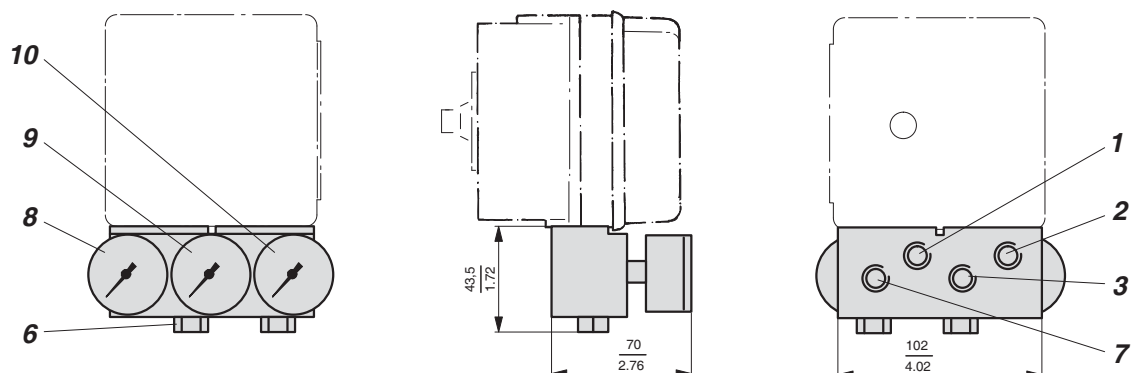

- 1 Internal thread 1/4-18 NPT for supply air
- 2 Internal thread (not used)
- 3 Internal thread 1/4-18 NPT for output I
- 4 Internal thread 1/4-18 NPT for output II
- 5 Internal thread 1/2-14 NPT for output I
- 6 Mounting screws SW17
- 7 Internal thread 1/4-18 NPT for output II (Connection manifold Code M only)
- 8 Code LEXG-MN: gauge for output I  
Code LEXG-JN : without gauges
- 9 Code LEXG-MN: gauge for supply air  
Code LEXG-JN : gauge for output
- 10 Code LEXG-MN: gauge for output II  
Code LEXG-JN : gauge for supply air

## 2.2 Attachment kit for diaphragm actuators acc. to DIN IEC 534-6 (NAMUR)

The attachment kits include the following parts:

- |                            |                                |
|----------------------------|--------------------------------|
| EBZG-KN:                   | EBZG-HN:                       |
| Mounting bracket <b>10</b> | Mounting bracket <b>10</b>     |
| Feedb. lever EBZG-AN       | Feedb. lever EBZG-AN <b>11</b> |
| Carrier bolt <b>12</b>     | Carrier bolt <b>12</b>         |
| U-bolts <b>14</b>          | Mounting screw <b>19</b>       |

### 2.2.1 Dimensions

Mounting bracket **10** Code G

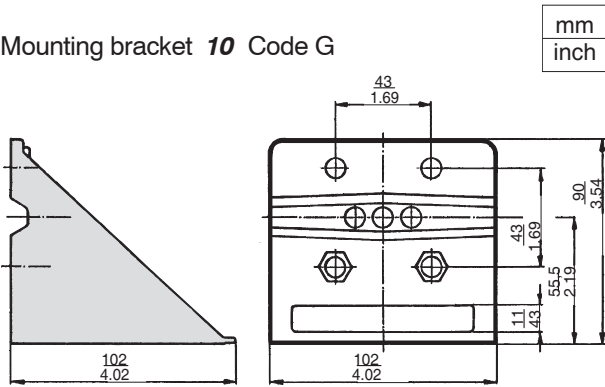

Feedback lever **11** with compensating spring **16**  
Code EBZG-AN

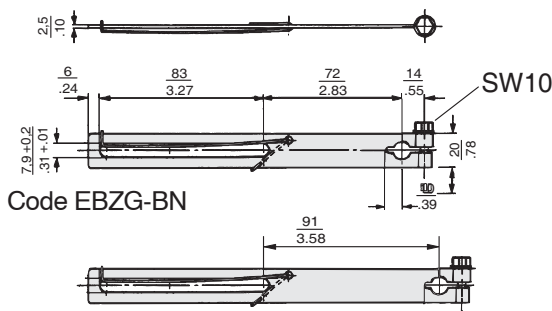

Carrier bolt **12**

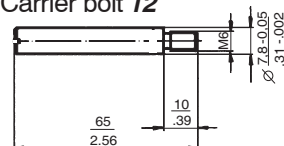

### 2.2.2 Determination of mounting side Single-acting diaphragm actuators

Check whether the actuator is in the safety position required by the process.

(Does the actuator open or close with spring force?)

The mounting side is selected from the table below in accordance with the direction of action and the required direction of movement of the spindle for an increasing input signal.

Actuator closes with spring force	Changeover plate setting	Actuator opens with spring force	Changeover plate setting

The arrow indicates the direction of movement of the spindle at increasing input signal.

The direction of action of the input signal can be set on the changeover plate **13** (see page 31):

- N = Normal direction of action (increasing input signal produces increasing control pressure to the actuator)
- U = Reverse direction of action (increasing input signal produces decreasing control pressure to the actuator)

### Double-acting diaphragm actuators

For double-acting positioners the changeover plate **13** always stays in the "N" setting. The assignment of the input signal to the direction of movement of the actuator spindle is determined by the selection of the mounting side of the positioner and the piping of the positioner outputs to the actuator:

If the actuator spindle is to ascend with an increasing input signal, output  $y_1$  is connected at top of the actuator and output  $y_2$  is connected at bottom. The positioner is mounted at the right-hand side.

If the actuator spindle is to retract with an increasing input signal, output  $y_1$  is connected at bottom and output  $y_2$  at top of the actuator. The positioner is mounted at the left-hand side.

	Changeover plate setting		Changeover plate setting

The arrow indicates the direction of movement of the spindle with an increasing input signal.



### 2.2.3 Attachment to diaphragm actuators

Attachment of the positioner is made using the attachment kit for diaphragm actuators according to DIN IEC 534-6 at right or left-hand side of the actuator.

- a) Screw the carrier bolt **12** into actuator coupling (see Fig. 12).
- b) Screw mounting bracket **10** flush with the positioner with two M 6 socket head cap screws (5 mm A/F).
- c) Fasten positioner with mounting bracket **10** to the diaphragm actuator.  
For FOXBORO ECKARDT diaphragm actuators with cast yokes:  
fasten mounting bracket **10** with screw **19** to the threaded hole in the cast yoke (see Fig. 10). This ensures that the feedback lever **11** is horizontal at 50 % stroke.  
For diaphragm actuators with pillars:  
fasten mounting bracket **10** with two U-bolts **14** to the pillar in such a manner that feedback lever **11** which is loosely attached to the shaft **15** of the positioner and the carrier bolt **12**, is horizontal at 50 % stroke (see Fig. 11).
- d) Set actuator to a 0 % stroke position.  
Attach feedback lever **11** to shaft **15** of the positioner and carrier bolt **12** in such a manner that compensating spring **16** is above the carrier bolt **12** when the mounting side is on the right, or below the carrier bolt **12** when the mounting side is on left (see Fig. 9).  
Align and lock carrier bolt.
- e) Press stroke factor lever **17** against stop screw and create a frictional connection between the feedback lever **11** and shaft of the positioner by tightening hexagon cap screw (10 mm A/F) of feedback lever.
- f) Connect positioner output  $y_1$  to diaphragm actuator for single-acting diaphragm actuators and connect outputs  $y_1$  and  $y_2$  to diaphragm actuator for double-acting diaphragm actuators.
- g) Set up electrical connections.
- h) Connect supply air of min. 1.4 bar to max. 6 bar, but no more than the maximum permissible operating pressure of the diaphragm actuator.
- i) **Fasten housing cover in such a way that air vent of attached device faces downwards** (see Mark '**M**' in Fig. 12).

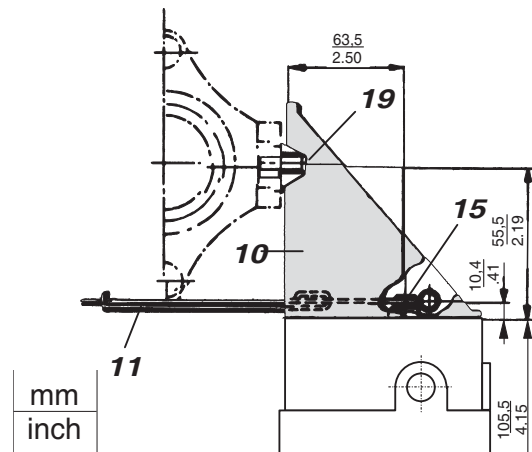

Fig. 10: Attachment to diaphragm actuator with cast yokes according to DIN IEC 534-6 (mounting side right) Code G

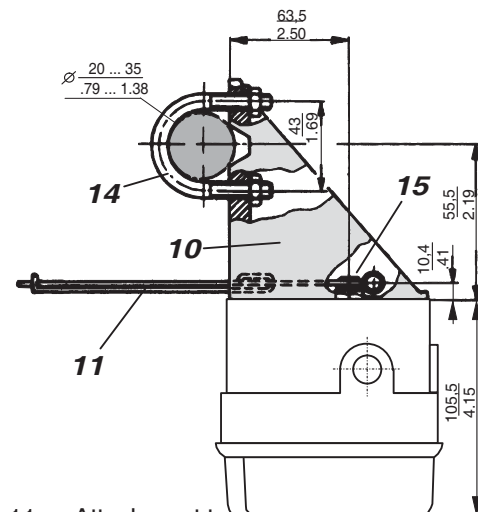

Fig. 11: Attachment to diaphragm actuator with pillars according to IEC 534-6 (mounting side right) Code F

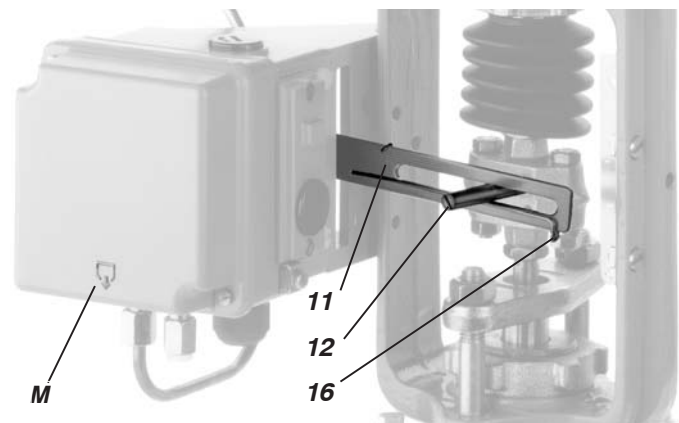

Fig. 12: Take-off point of the positioner (mounting side left)

## 2.3 Attachment kit for rotary actuators

For attachment of the positioner to rotary actuators or rotary armatures an attachment kit is required. The linear cam enables sensing of rotation angles

up to 120°, whereas the equal percentage and the inverse equal percentage cams sense rotation angles up to 90° (linear characteristic between 70° and 90°).

### 2.3.1 Version with shaft

(acc. to VDI/VDE 3845) Code EBZG-ZN

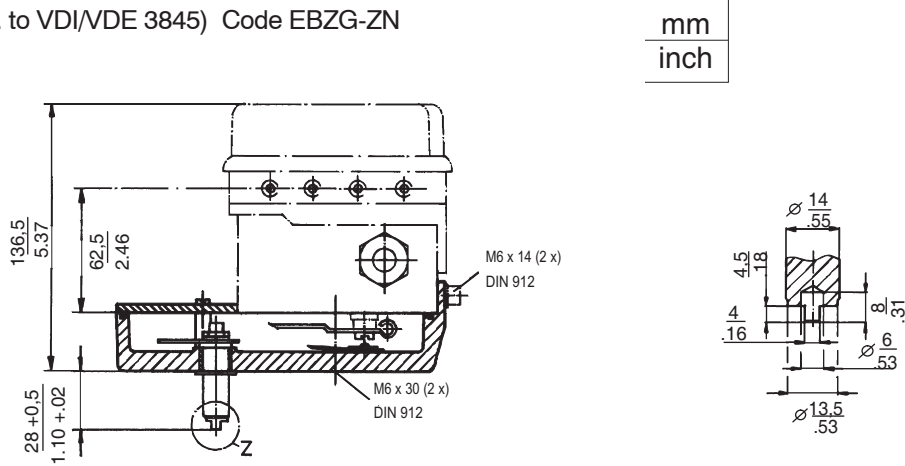

### 2.3.2 Version with flange Code EBZG-JN

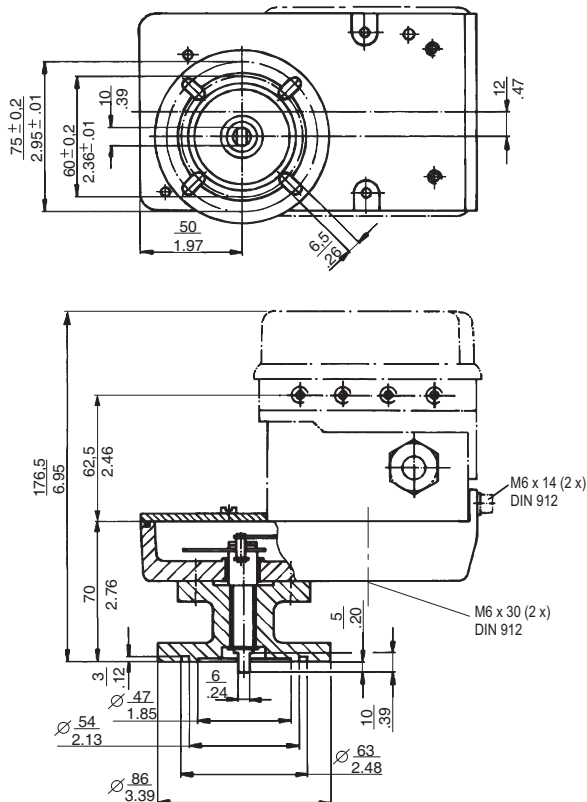

Rotation angle max. 120°;  
torque requirement 0.14 Nm

**2.3.3 Version without flange**

Code EBZG-NN, -PN

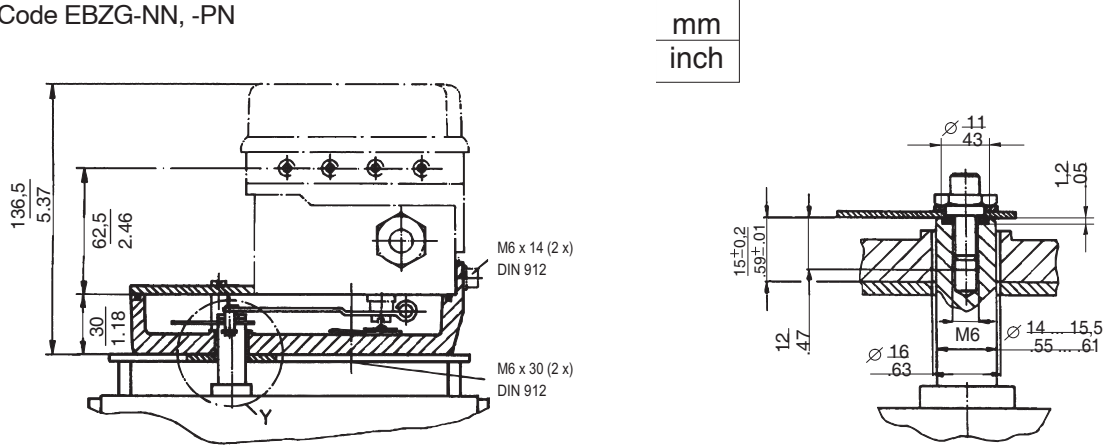

Adaptation of the actuator drive shaft and correct axial location required at site!

**2.3.4 Housing dimensions of attachment kits for rotary actuators**

For all versions  
Code EBZG-NN

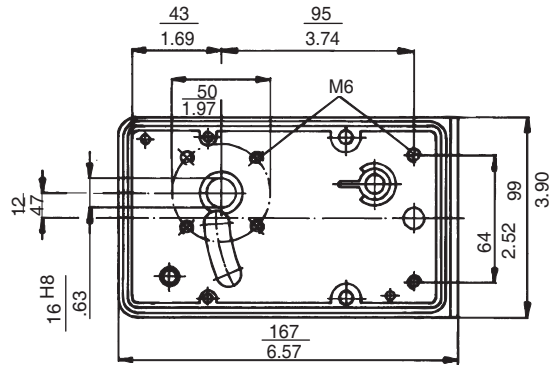

For version without flange  
Code EBZG-PN

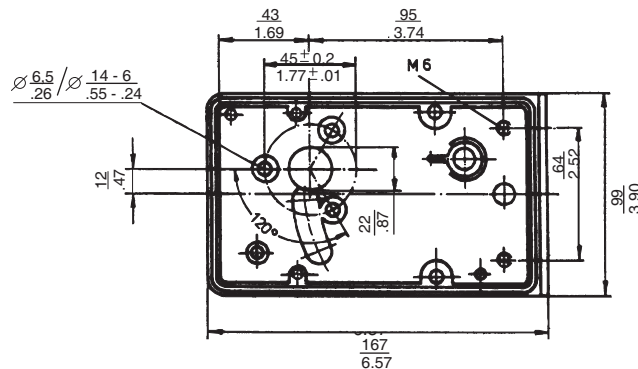

**2.3.5 Attachment to rotary actuators**

- a) Remove the transparent cover plate from the housing of the attachment kit.
- b) Mount the housing of the attachment kit on rotary actuator or armature; use mounting hardware supplied by the actuator manufacturer if necessary.



Fig.13: Rotary actuator with attachment kit for rotary actuators

- c) Move actuator into the desired starting position (rotation angle = 0°).
- d) Mount cam **24** in accordance with the direction of rotation of the actuator (see Fig. 14). The linear cam is fastened to the actuator drive shaft in such a manner that the dimension x or y (Fig. 15) amounts 2 mm, whereas in case of equal percentage cam the dimension x is approx. 17.5 mm, and the dimension y is approx. 21.5 mm. In case of inverse equal percentage cam the dimension x is approx. 18 mm, and the dimension y is approx. 23 mm. When employing equal percentage and the inverse equal percentage cams, the range spring FES 627/1 must be installed in the positioner.

A = Mounting position for actuator rotation ↙  
 B = Mounting position for actuator rotation ↘

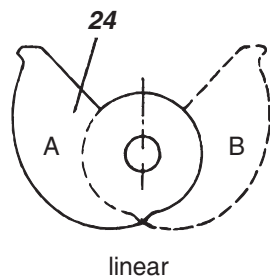

linear

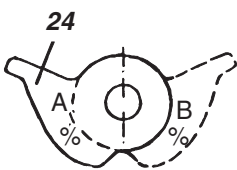

equal percentage

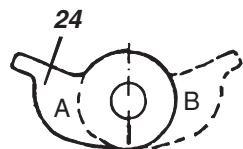

inverse equal percentage

Fig.14: Mounting position of the cams **24**

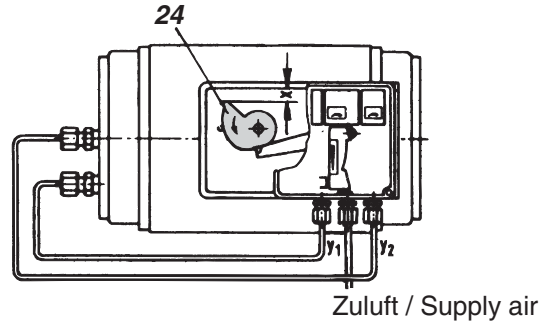

Zuluft / Supply air

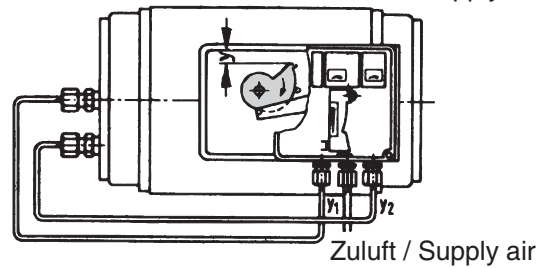

Zuluft / Supply air

Fig.15: Rotary actuator with attachment kit for rotary movement and double-acting positioner

- e) Fasten feedback lever **30** for the rotary actuator onto shaft **15** of positioner as shown in Fig. 16.

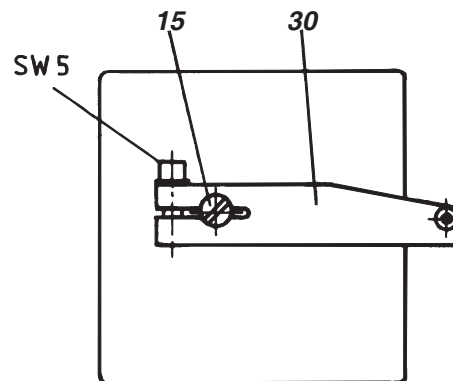

Fig. 16: Attaching feedback lever to the positioner

- f) Mount positioner on housing of attachment kit. Attach spring **31** to feedback lever **30** and cam follower **32** against cam (see Fig. 17).

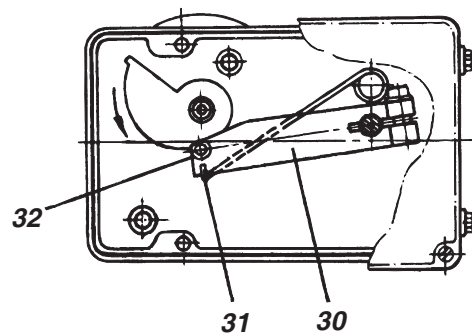

Fig.17: Attachment of positioner to rotary actuator. Alignment of cam

Screw positioner to housing of attachment kit. With the linear cam and the inverse equal percentage cam check whether mark **33** points to the center of the cam follower **32** (see Fig. 18); adjust if necessary.

With the equal percentage cam check whether the cam follower lies directly ahead of the start of the cam lobe; adjust if necessary.

- g) Final mounting of feedback lever on shaft of positioner is performed at a stroke of 0 %, i.e. a rotation angle of 0°. First loosen 5 mm A/F Allen screw of feedback lever **30** through hole **34** (see Fig. 19), then press stroke factor lever **17** against stop screw **18** (see page 31) and tighten Allen screw firmly.

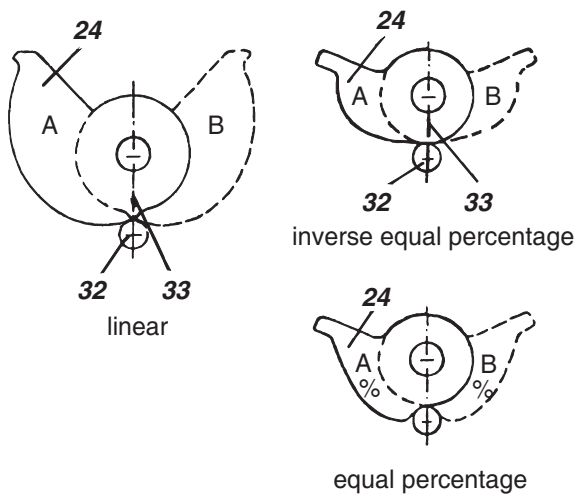

Fig. 18: Alignment of cam **24**



Fig. 19: Tightening feedback lever

- h) With single-acting actuators connect positioner output  $y_1$  to actuator; with double-acting actuators connect  $y_1$  and  $y_2$  to actuator.

Connect chamber in which pressure is to be built up with an increasing input signal to  $y_1$ .

- i) Connect command variable  $w$  (input).  
k) Connect supply air of min. 1.4 bar to max. 6 bar but do not exceed the maximum permissible operating pressure of the actuator.

**Note !**

If actuator moves to an end position, the mounting position of cam does not coincide with the direction of rotation of the actuator.

In this case install the cam **24** in the reverse position.

- l) Attach pointer **35** on the headed screw in such a manner that 0° is indicated when the rotary actuator is in its starting position ( $w = 0$ ).

- m) Attach the transparent cover plate (see Fig. 20).

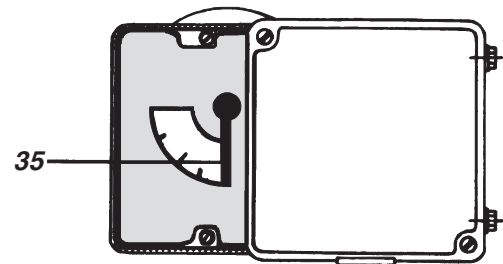

Fig.20: Attachment of pointer **35** and transparent cover plate

### 2.3.6 Reversing direction of rotation

Single-acting actuator:

move changeover plate (page 31, item 13) to 'U' setting and reverse cam **24**.

Double-acting actuators:

exchange positioner outputs and reverse cam (see Fig. 15). The changeover plate (page 31, item 13) remains in 'N' setting.

### 3 ELECTRICAL CONNECTIONS

During installation, the installation requirements by DIN VDE 0100 and/or DIN VDE 0800, as well as locally applicable requirements must be observed.

In addition, the requirements of VDE 0165 must be observed for systems associated with hazardous areas.

Further important instructions are contained in page 22 (safety requirements, explosion protection).

If an earth connection or potential equalization are required, the appropriate connections must be set up for an internal earth connection **36** or an external earth connection **37**.

The units must be operated in a stationary position.

The line (cable) is guided through a screwed gland **7** Pg 13.5. This is suitable for line diameters of 6 to 12 mm.

The electrical connections for the command variable  $w$  is made at the + and – screw terminals **38**, which are suitable for wire cross-sections of up to 2.5 mm<sup>2</sup> (see Fig. 21).

Check polarity !

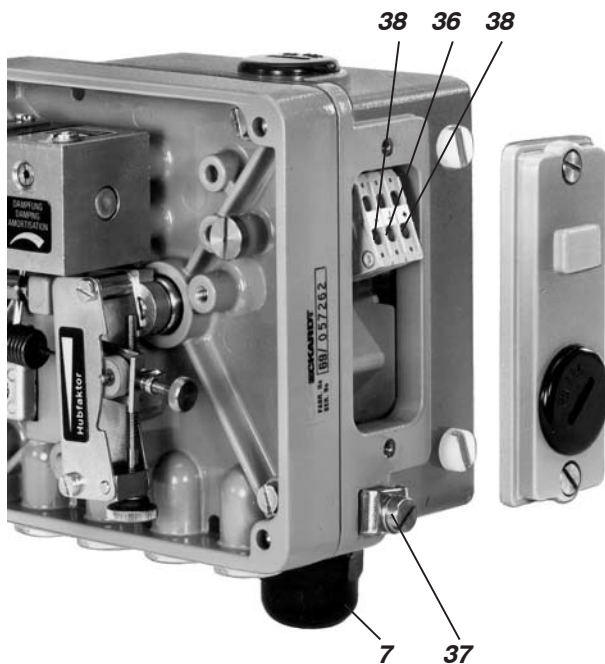

Fig. 21: Electrical connections

### 4 START-UP

Before commissioning electro-pneumatic positioners must be matched to the stroke and rotation angle of the actuator and to the input signal range.

The instruments can be connected to the 0 to 20 mA input signals, 4 to 20 mA input signals or split ranges **without altering the basic adjustments**.

The supply air connected should be min. 1.4 bar and max. 6 bar, but should not exceed the maximum operating pressure of the diaphragm actuator.

#### 4.1 Setting the gain

The gain and thus the sensitivity of the positioner are set by means of the throttling screw **44** (see page 31). The throttling screw is screwed in all the way in the factory, i.e. it is set to maximum gain. This gain varies with the supply air pressure, as shown in the following table:

Supply air	max. gain	
	Single-acting positioner	Double-acting positioner
1.4 bar	approx. 150	approx. 100
4 bar	approx. 90	approx. 150
6 bar	approx. 60	approx. 180

The linear gain is indicated. These values are based on the built-in range spring FES 628/1.

From this basic setting the gain can be matched to the dynamic requirements of the control system (counter-clockwise rotation of the throttling screw **44** results in less gain).

#### Note :

The zero point must be adjusted following each change of gain.

In order to ensure reliable pressure reduction in the actuator, the throttling screw **44** should not be opened beyond ¼ turn at 6 bar. A limiting screw **45** is therefore incorporated.

The basic setting at the factory permits a maximum opening of the throttling screw **44** of approx. 1 turn.



### 4.2 Setting of zero point and stroke

(see page 31)

Before commencing settings press the flapper lever **40** several times alternately to the left and right in order to align the flappers correctly.

- a) Set the minimum value of the command variable w (start of stroke).
- b) Turn zero screw **41** until actuator just begins to move from its end position.

**Note:**

In accordance with VDI/VDE 2174 a variation of the stroke range up to 2 % is permissible in one of the two end positions. It is advisable to take advantage of this tolerance for the input signal range 0 to 20 mA by elevating the minimum value somewhat above 0 mA (approx. 0.1 mA; max. 0.4 mA). This will ensure that the actuator completely decompresses if necessary for safety reasons.

- c) Set maximum value of the command variable w (end of stroke).
- d) Turn the stroke factor screw **42** until actuator precisely reaches its end position:
  - Right turn: decrease of travel
  - Left turn: increase of travel
 Recheck zero and stroke settings.

**Note:**

When stop screw **18** is correctly positioned and feedback lever is correctly mounted, there is no interaction between the adjustments of zero and stroke.

If the stroke cannot be adjusted with the installed spring, the correct spring can be approximately determined in accordance with the following criteria:

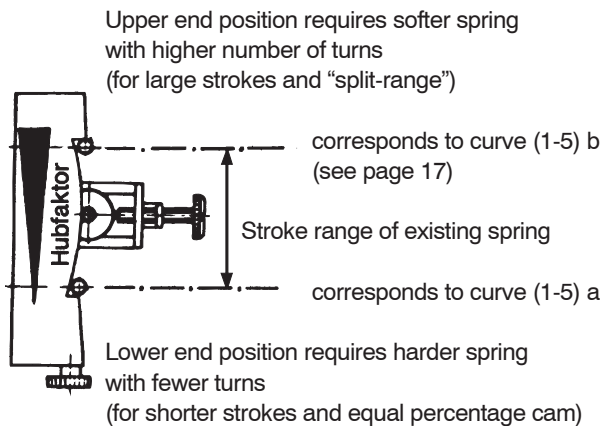

There are 5 differently rated springs available for matching the stroke and input signal range. The particular spring required can be determined precisely via stroke factor  $U_x$ .

### 4.3 Setting the damping

(see page 31)

The air output capacity of the positioner can be reduced by means of the damping throttle **46**. Double-acting positioners are equipped with a damping throttle **47** for correcting the variable y1 and a damping throttle **48** for correcting the variable y2. In its normal setting the damping throttle is approximately flush with the amplifier housing.

The air output capacity is reduced by a factor of approximately 2.5 when the damping throttle is turned completely in.

A reduction of the air output capacity should only be done for very small actuator volumes since the control system would otherwise be too slow.

Page 31, single-acting positioner: Setting gain **44** and damping **46**

Page 31, double-acting positioner: Setting gain **44** and damping **47, 48**

### 4.4 Subdivision of input range (split range)

If several actuators are to be controlled by the same command variable and the complete stroke is to be executed in only one specific subrange of this command variable at a time, a positioner, the zero point and stroke range of which must be set to the desired sub-range of the command variable, must be provided for each actuator.

For actuation of several positioners by a master controller the positioners are connected in series.

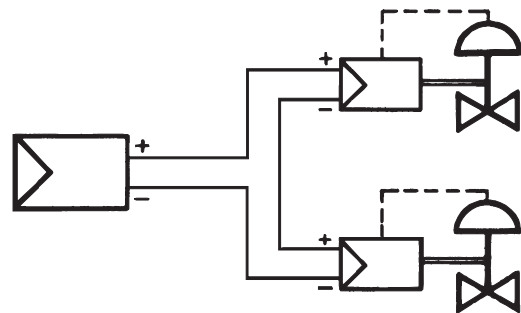

Fig. 22: Example of 2-way split range

It should be noted that the permissible load of the controller may not be exceeded. The input resistance of the positioner at 20 °C is approx. 200 ohms.

Selection of the correct range spring can be made in accordance with the stroke factor range or the graph of the range springs (see page 17).

If the zero point has to be increased by **more than 10 mA** in case of multiple subdivision the adjustment must be made as follows: (see page 31)

- a) Shut off supply air.
- b) Remove tension from range spring **43** by turning zero screw **41**.
- c) Loosen hexagon cap screw (A/F 10) of feedback lever and turn stroke factor lever **17** away from stop screw **18**. This applies pretension to range spring **43**. In this position retighten hexagon cap screw of feedback lever.
- d) Connect supply air.
- e) Set the minimum value of command variable  $w$  (start of stroke).
- f) Turn zero screw **41**, until the actuator begins to move from its end position. If this is not possible, the pretension of the range spring must be increased as described in c).
- g) Set maximum value of command variable  $w$  (end of stroke).
- h) Turn stroke factor screw **42** until the actuator precisely reaches its end position.

#### Note !

With this setting the zero point and stroke range are mutually dependent. Settings e) to h) must therefore be repeated as often as necessary until both settings are correct. Furthermore it should be noted that the deflection of the stroke factor lever **17** from the starting position may not exceed a maximum of 39°, since the stroke factor lever might otherwise hit the housing cover before reaching its end value.

## 4.5 Determination of rotation angle factor $U_\varphi$

In conjunction with the attachment kit for rotary actuators (Code P, M, J, Z, R) the rotation angle factor  $U_\varphi$  can be determined as follows:

$$U_\varphi = \frac{\varphi}{\Delta w} = \frac{\text{Rotation angle}}{\text{Input signal range [ mA ]}}$$

The rotation angle factors  $U_\varphi$  of the individual range springs are stated in the following table.

The rotation angles are also taken into account in the graph of the range springs (see page 31).

## 4.6 Determination of stroke factor $U_x$

The stroke factor  $U_x$  is the ratio of the entire range of the output variable (stroke  $x$ ) to the entire range of the input variable (command variable  $w$ ).

For FOXBORO ECKARDT diaphragm actuators PA200 to PA700/702 :

$$U_x = \frac{x}{\Delta w} = \frac{\text{Stroke in mm}}{\text{Input signal range in mA}}$$

For FOXBORO ECKARDT diaphragm actuators (1500 cm<sup>2</sup>) and actuators of other manufacturers ( $l_o = 117.5 \text{ mm}^1$ ):

$$U_x = \frac{x}{\Delta w} \times \frac{l_o}{l_s}$$

$l_s$  = Feedback lever length in mm (for FOXBORO ECKARDT actuator 1500 cm<sup>2</sup>:  $l_s = 122.5 \text{ mm}$ )

The stroke factor can be used to determine for each application whether or with which spring the desired setting can be made.

Five different range springs are available for matching to the stroke and input signal range.

Range spring			Cam <sup>1)</sup>		Stroke factor range		Remarks	
Ident No.	old ID	Colour	linear	Equal perc. And inverse equal perc.	Stroke factor $U_x$	Stroke range <sup>2)</sup>		
			max. 120°	max. 90°	$\frac{\text{mm}}{\text{mA}}$	mm		
1	420 493 013	FES 627/1	yellow	1.7 ... 4.7 (max. 7.0)	2.4 ... 8 (max. 10)	0.4 ... 1.2 (max. 1.7)	8 ... 34	2)
2	420 494 019	FES 628/1	green	3.5 ... 9.5 (max. 14.0)	5.0 ... 15 (max. 20)	0.85 ... 2.3 (max. 3.35)	17 ... 68	built-in
3	502 558 017	FES 612/1	- whitout -	5.8 ... 14.5 (max. 21.75)	8.2 ... 24 (max. 28)	1.4 ... 3.5 (max. 5.25)	28 ... 105	2)
4	420 496 011	FES 715/1	gray	8.4 ... 21.5 (max. 32.75)	12.0 ... 35 (max. 43)	2.0 ... 5.5 (max. 7.9)	40 ... 158 <sup>3)</sup>	2)
5	420 495 014	FES 629/1	blue	11.5 ... 27.5 (max. 41.5)	-	2.75 ... 7.0 (max. 10.0)	55 ... 200 <sup>3)</sup>	2)

1) For equal percentage and inverse equal percentage cams the rotation angle factors are a function of their corresponding rotation angles.

2) Included in FESG-FN (Ident-Nr. 420 496 011)

**4.6.1 Stroke factor ranges of the range springs**

The stroke factor  $U_x$  determined as described above should lie within the ranges of the respective range springs indicated in the following table, as close as possible to the **lower** value.

**4.6.2 Characteristics of the range springs**

The stroke  $x_o$  is based on the FOXBORO ECKARDT standard feedback lever  $l_o=117.5$  mm.

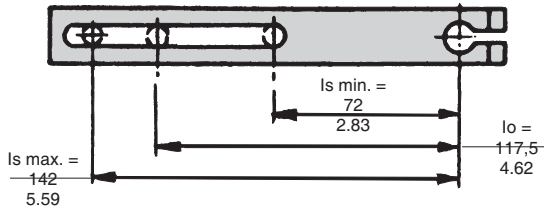

Fig. 23: Feedback lever

If another length ( $l_s$ ) is used, the actual stroke  $x_s$  must be converted to stroke  $x_o$

$$x_o = \frac{117.5 \cdot x_s}{l_s} \text{ [mm]}$$

**Selection of measuring spring and setting of measuring span**

Determination of suitable spring for split range:

- a) Enter desired setpoint value  $w$  for travel start in the diagram field.
- b) Determine  $x_o$  if  $l_s$  unequal 117.5 mm.
- c) Enter intersection  $w/x_o$ .

- d) Connect points determined at a) and c). This results in a straight line.
- e) If the straight line does not run through the origin, move this parallel here.
- f) Use the spring the characteristic line (a) of which is located directly below the presently determined characteristic line.

**Example** (shown in graph)

Split range operation

Valve 1:

$$w = 0 \dots 10 \text{ mA}$$

$$x_s = 30 \text{ mm (stroke range)}$$

$$l_s = 140 \text{ mm}$$

$$x_o = \frac{117.5 \cdot 30}{140} = 25.2 \text{ mm}$$

Intersection  $w = 10 \text{ mA}$  with  $x_o = 25.2 \text{ mm} \rightarrow S_1$

Selected: Spring 4 (FES 715/1) because the characteristic curve based on the beginning of the determined straight line located directly below.

Valve 2:

$$w = 10 \dots 20 \text{ mA}$$

$$x_s = 50 \text{ mm (stroke range)}$$

$$l_s = 140 \text{ mm}$$

$$x_o = \frac{117.5 \cdot 50}{140} = 42 \text{ mm}$$

Intersection  $w = 20 \text{ mA}$  with  $x_o = 42 \text{ mm} \rightarrow S_2$

Selected: Spring 5 (FES 629/1) because the characteristic curve based on the beginning of the determined straight line located directly below.

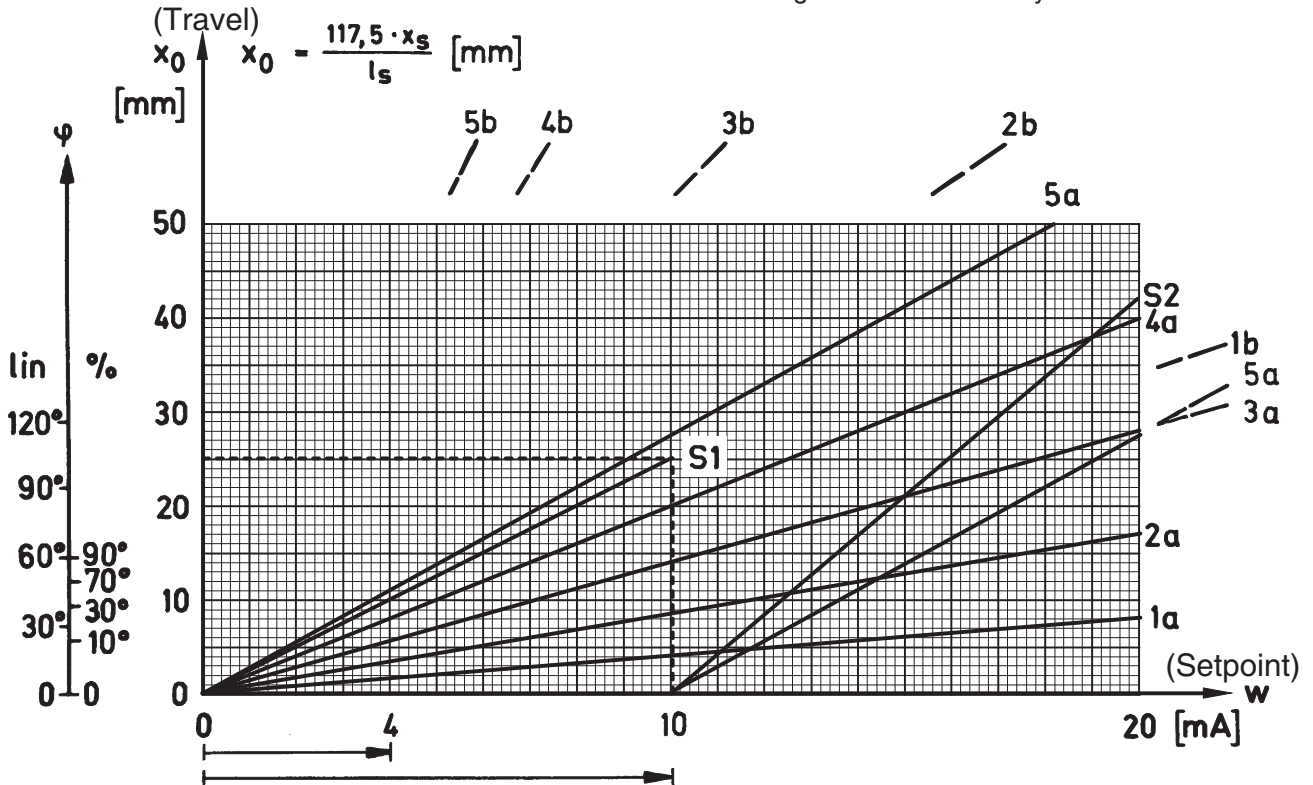

Lifting up of zero point for 4 ... 20 mA and split range  
 1a, 2a, 3a, 4a, 5a = stroke starting of the respective spring  
 1b, 2b, 3b, 4b, 5b = max. stroke

- 1)  $l_o$  = FOXBORO ECKARDT standard feedback effective length
- 2) For feedback effective length  $l_s = 117.5$  mm and  $\Delta w = 20$  mA
- 3) Theoretical value

## 5 MAINTENANCE

### 5.1 Basic Adjustment of Single-acting Positioner (pneumatic part)

Basic setting is only necessary after dismantling the device or changing modules.

All the settings for adapting the positioner to the actuator are described in page 14 (start-up).

#### Note:

If alterations were made to the I-p converter **65** (see Fig. 30), this must also be adjusted (see page 20).

The following tools are required for basic adjustment:  
screwdriver

1 open-end spanner 7 mm A/F

1 feeler 0.6 mm

1 test gauge 1.6 bar

1 DC signal generator

The feedback lever must be detached from the shaft of positioner if adjustment is done in the attached state.

For the following adjustments see pages 30 and 31.

- a) Set changeover plate **13** to "N".
- b) Turn throttling screw **44** to the right as far as possible (maximum boost).
- c) Unhook range spring **43** from flapper lever **40**.
- d) Check whether the flappers **60** are concentric with the nozzles **59**. If not, align booster **61**. The fastening screws of the booster are accessible after removing the I-p converter (see 5.3.1).
- e) Push flapper lever **40** alternately to the left and right several times to align the ball-guided flappers parallel to the nozzles.
- f) Push flapper lever **40** to the left. By turning the hexagonal rod **66** 7 mm A/F set the distance between the right-hand nozzle and the right-hand flapper to approx. 0.6 mm with the aid of a feeler. Then fasten the hexagonal rod tight.
- g) Connect the positioner as shown in the test circuit, fig. 24, preset supply air to 1.4 bar.
- h) Press flapper lever **40** to the left. If the output  $y$  does not rise to supply air pressure, there are leaks or the flapper is not correctly positioned (repeat 'e').
- i) Hook range spring **43** into flapper lever and preset DC signal  $w = 10$  mA. Proceed as follows to make zero setting independent of the stroke setting:

- k) Press stroke factor lever **17** against stop screw **18**.
- l) Set a large stroke factor (approx. 2 mm in front of top stop) with stroke factor screw **42**.
- m) Set zero screw **41** so that the output pressure  $y =$  approx. 0.6 bar and note this value.
- n) Set a small stroke factor (approx. 2 mm in front of bottom stop) with the stroke factor screw. The output pressure  $y$  may not change by more than  $\pm 150$  mbar in relation to setting m).
- o) The stop screw **18** should be adjusted in case of greater deviations. Repeat settings l) to n) after every adjustment of the stop screw **18** until the deviation is less than  $\pm 150$  mbar.
- p) Secure stop screw **18** with varnish. Put changeover plate **13** back in its original position. Reinstall positioner or reattach the feedback lever to positioner shaft.

See page 14 for start-up.

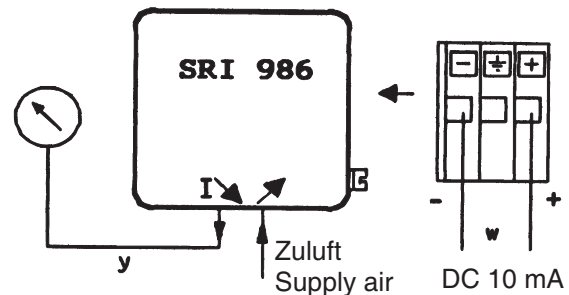

Fig. 24: Test circuit for single acting positioner

## 5.2 Basic Adjustment of the Double acting Positioner (pneumatic part)

Basic setting is only necessary after dismantling the device or changing modules.

All settings for adapting the positioner to the actuator are described in page 14 (start-up).

### Note:

If alterations were made to the I-p converter **65** (see Fig. 30), this must also be adjusted (see page 20).

The following tools are required for basic adjustment: screwdriver

1 open-end spanner 7 mm A/F

1 feeler 0.6 mm

2 test gauges 6 bar

1 DC signal generator

The feedback lever must be detached from the shaft of the positioner if adjustment is done in the attached mode.

For the following adjustments see pages 30 and 31.

- Leave changeover plate **13** set to "N".
- Turn throttling screw **44** to the right as far as possible (maximum boost).
- Unhook range spring **43** from flapper lever **40**.
- Check whether flappers **60** are concentric with nozzles **59**. If not, align booster **61**. The fastening screws of the booster are accessible after removing I-p converter (see 5.3.1).
- Push flapper lever **40** alternately to the left and right several times to align ball-guided flappers parallel to nozzles.
- Push flapper lever **40** to the left. By turning the hexagonal rod **66** 7 mm A/F set the distance between the right-hand nozzle and the right-hand flapper to approx. 0.6 mm with the aid of a feeler. Then fasten hexagonal rod tight.
- Connect positioner as shown in the test circuit, fig. 25, preset supply air to 6 bar.
- Press flapper lever **40** to the right and left. The pressures  $y_1$  and  $y_2$  must change in opposition between 0 and supply air pressure.
- Hook range spring **43** into flapper lever and preset DC signal  $w = 10$  mA.
- Set zero screw **41** so that pressures  $y_1$  and  $y_2$  are equal.

- Set adjustment screw **67** so that pressures  $y_1$  and  $y_2$  are set to approx. 4.2 bar (70 % of the supply air pressure). Repeat settings k) and l) alternately if necessary.

- Preset 1.4 bar supply air.

Set zero screw **41** so that pressures  $y_1$  and  $y_2$  are equal. They should be approx. 0.7 bar (50 % of the supply air pressure) (check measurement only).

Proceed as follows to make the zero setting independent of the stroke setting:

- Press stroke factor **17** lever against the stop screw **18**.
- Set a large stroke factor (approx. 2 mm in front of the top stop) with the stroke factor screw **42**.
- Set the zero screw **41** so that output pressures  $y_1$  and  $y_2$  are equal.
- Set a small stroke factor (approx. 2 mm in front of the bottom stop) with the stroke factor screw. The output pressures  $y_1$  and  $y_2$  may not change by more than  $\pm 150$  mbar in relation to setting p).
- The stop screw **18** should be adjusted in case of greater deviations. Repeat settings o) to r) after every adjustment of stop screw **18** until the deviation is less than  $\pm 150$  mbar.
- Secure stop screw **18** with varnish. Reinstall the positioner or reattach the feedback lever to positioner shaft.

See page 14 for start-up.

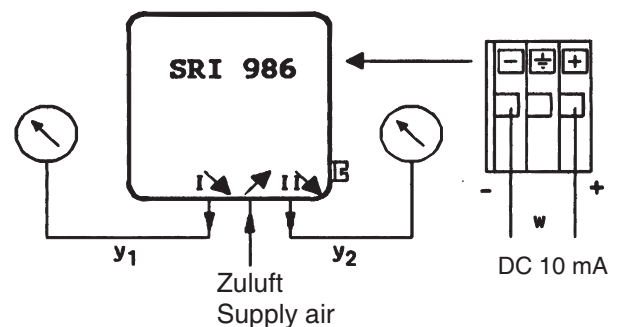

Fig. 25: Test circuit for double acting positioner



### 5.3 Checking and Adjusting I-p Converter

(see also page 31)

#### Note:

Press the flapper lever **40** to the left to check whether a prevailing malfunction was caused by the I-p converter or by the pneumatic part. If the output pressure ( $y_1$ ) rises to the supply air pressure, the malfunction should be looked for in the I-p converter.

#### 5.3.1 Removal of I-p converter (see Fig. 30)

- Unscrew housing cover **68** .
- Unscrew shaft **69** with the 5 mm A/F Allen key (turn to left), unhook range screw **43** and remove stroke factor lever **17** .
- Unscrew 4 cylinder head screws **70** and remove air vent plate **71** .
- Unscrew the two Allen screws **72** (3 mm A/F) and remove the I-p converter **65** .

#### 5.3.2 Check and adjust I-p converter

(see Fig. 28)

An adapter is required for checking and adjusting the I-p converter which can be done by yourself as shown in Fig. 26.

The following tools are required:

screwdriver,  
3 and 5 mm A/F allen keys,  
1 test gauge 0 to 1.4 bar,  
1 DC signal generator 0 to 20 mA,  
supply air  $1.4 \pm 0.1$  bar.

- Connect the I-p converter to the adapter, Fig. 26 and wire as shown in Fig. 27.
- Preset supply air  $1.4 \pm 0.1$  bar.
- The test gauge must read 0.18 to 0.19 bar at current signal 0 mA. Otherwise set the adjustment lever **73** so that this value is indicated. If this is not possible, remove the Venturi **56** (see Fig. 29) and clean it.
- Increase the current signal slowly from 0 to 20 mA. The test gauge reading must change proportionately to the current signal.

Current signal	Test gauge reading
0 mA	0.18 ... 0.19 bar
20 mA	approx. 1 bar

If these values are not achieved, there is a defect and the I-p converter should be replaced or the positioner returned to the manufacturer for repair.

#### 5.3.3 Clean the Venturi (see Fig. 29)

- Remove I-p converter
- Unscrew two screws **74** , remove the cover plate **75** and Venturi **56** .
- Clean the Venturi **56** with compressed air and a brush.
- Reinsert the Venturi. Tighten the two screws **74** equally. If the base plate **76** has also been dismantled, take care that the 3 O-rings and the filter are correctly positioned.
- Check I-p converter and adjust, if necessary.

#### 5.3.4 Insert I-p converter and assemble the device (see Fig. 30)

- Attach the I-p converter **65** . Make sure that the electric lead is located along the bottom of the I-p converter in the appropriate channel and that both O-rings are in place.
- Screw on air vent plate **71** . Put the electric lead **77** around the shaft of the positioner **69** in such a way that the functioning of the I-p converter is not impaired.
- Hook in range spring **43** and screw shaft **69** to stroke factor lever **17** .
- Screw on the housing cover **68** so that the air vent of the attached device faces downwards.

#### Note:

Basic adjustment and re-start-up (see page 14) are necessary after dismantling the device or after replacing components or modules.



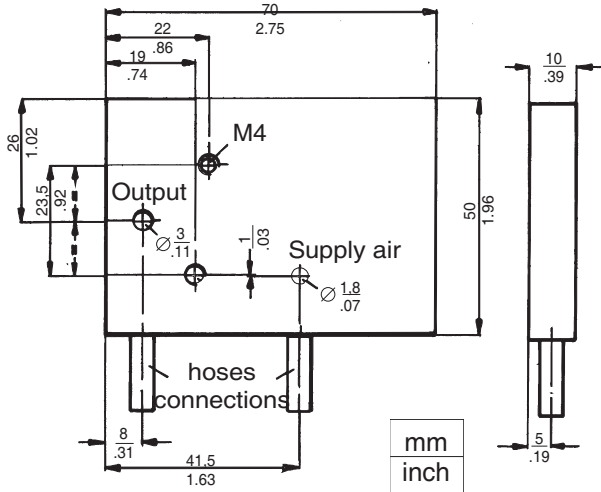

Fig. 26: Test adapter for I-p converter

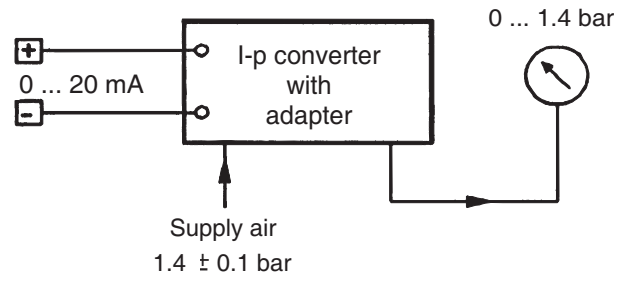

Fig. 27: Test circuit for I-p converter

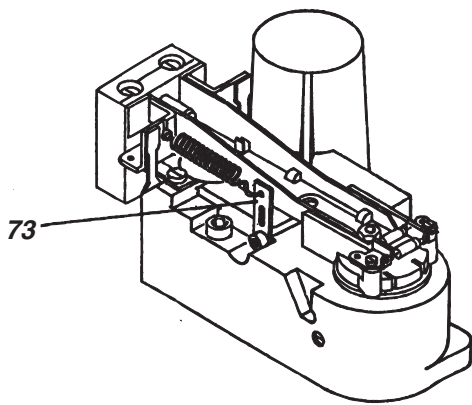

Fig. 28: Adjustment of the I-p converter

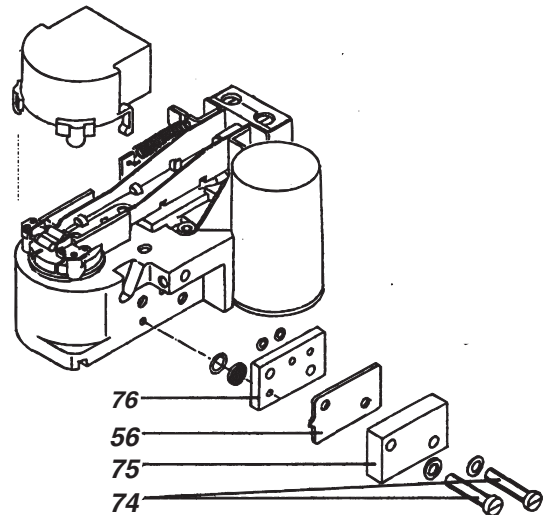

Fig. 29: Removal of the Venturi

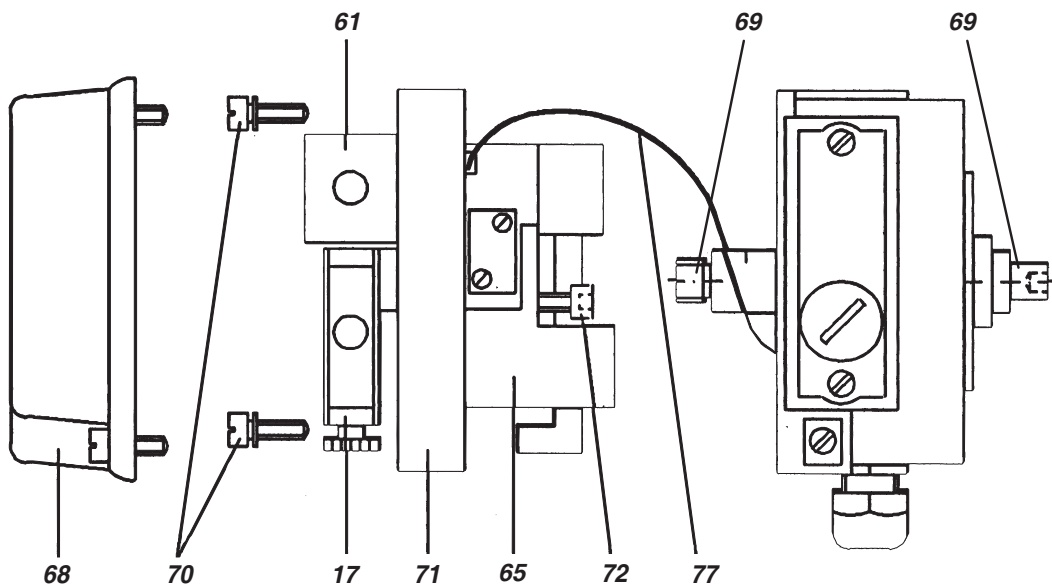

Fig. 30: Removal and reassembly of the I-p converter **65** and the booster **61**

## 5.4 Cleaning throttles

- a) Remove the limiting screw **45** .
- b) Remove the throttling screw **44** from the limiting screw from below.
- c) Clean the throttling screw **44** in a solvent (e.g. benzene) and then carefully blow through. Cleaning in an ultrasonic bath is better still.
- d) Screw in throttling screw **44** completely again to its stop (clockwise).
- e) Screw in limiting screw **45** completely to its stop (clockwise), then unscrew by approx. one half turn counterclockwise.
- f) Secure the limiting screw **45** with sealing paint.

## 6 BOOSTER REPLACEMENT

- a) Remove I-p converter.
- b) Unscrew the booster **61** from the air vent plate.
- c) Screw on the new booster.  
To exchange a single-acting booster by a double-acting one, you have to unscrew the sealing screw **78** first. Remember the O-rings between the booster **61** and the air vent plate (single-acting positioner four O-rings, double-acting positioner six O-rings).  
Before tightening the mounting bolts align booster **61** in such a manner that the flappers **60** are concentrically opposite the nozzles **59** .
- d) Insert I-p converter and assemble the device.

## 7 SAFETY REQUIREMENTS

### 7.1 Accident prevention

This device complies with the regulations for the prevention of accidents **Power-Driven Work Aids** (VBG 5) of October 1st, 1985.

### 7.2 Electrical safety

#### 7.2.1 General requirements

This device fulfils the requirements stipulated in IEC 1010-1, Class III equipment.

When the housing is open, repair and maintenance operations must always be carried out by service personnel if any power sources are connected to the device.

The device contains no built-in fuses. Protection against shock must be provided in the system for Class I equipment.

#### 7.2.2 Regulations for Connection

The device is to be used according to its purpose and is to be connected in compliance with its connection plan (see section 3). The locally effective national directives for electrical installations are to be observed, e.g. in the Federal Republic of Germany DIN VDE 0100 resp. DIN VDE 0800.

The device may be connected to extra low voltage circuits the insulation of which against hazardous voltages (e.g. 220 V mains) at least meets the requirements for basic insulation.

Before connection of other leads and during operation the protective conductor must be connected to the appropriate terminal.

If the connected circuits fulfill the requirements stipulated in IEC 348 relating to the safety extra low voltage, the device may be operated without a protective conductor (Class III equipment).

### 7.3 Explosion protection

(only if ordered specifically)

The setup regulations VDE 0165 or the ElexV or the corresponding national setup regulations must be observed when setting up.

#### Attention!

Observe the corresponding national requirements for repairing explosion-protected devices.

The following applies to the Federal Republic of Germany: Repairs on parts on which the explosion protection depends must either be done by the manufacturer or must be checked by an authorized expert and approved by his test mark or a certificate.

### 7.4 EMC and CE

For references pertaining to electro-magnetic compatibility EMC and regarding CE certification see product specifications PSS EVE0102 A-(en).

## 8 Option "Limit switch"

The limit switches are additional equipment either installed in the factory or up-dated. They are constructed either with inductive switches or micro switches and signal exceeding or deceeding of a stroke or rotating movement of actuators.

### 8.1 Method of operation

Stroke or rotation angles of the actuators are transferred to the control vanes via a deviating mechanism to the control vanes which either dampen an oscillator circuit or switch a mechanical contact depending on the version.

The inductive limit switches are supplied with power via a separately mounted switch amplifier. The current signal is transferred into a switch output.

In the three-wire version an integrated switch amplifier supplies a switch signal; direction of reaction PNP closing function.

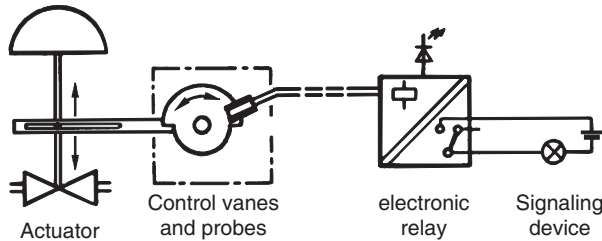

Functional schematic (acc. to DIN 19324 / NAMUR)

We recommend the following switch amplifiers:

Separating switch amplifier with relay output

Pepperl+Fuchs GmbH type numbers:

Normal version WE 77/Ex2

Safety version WE 77/Ex-SH-03

For further information see above documentation.

### 8.4 Start-up

The switching functions may be freely selected and set.

The control vanes may be adjusted as desired in order to reach the wanted switching behavior. The illustration here shows the four basic settings and adjacent the respective switch behavior (gray=immersed vane).

The examples are based on the following setting: Mounting left=feedback level right; transmission is selected so that at stroke x from 0 to 100% the guidance shaft travels through a rotary angle of 180°. Illustrated in resting position x = 0%.

2-wire technique: if control vane is immersed the initiator power circuit becomes high-ohmic.

3-wire technique: if control vane is immersed the contact is closed against plus.

Micro switch: Contact opens during passing of the control vanes.

## 8.2 Electrical connection

Grounding conductor connection following installation in the SRI986 - see page 14.

### 8.3 Arrangement of Connection

The connection cable is guided through the cable gland 12 Pg 13.5 (cable diameter 6...12 mm) and connected to terminal bar 6.

The terminals are tied up as follows:

2-wire technique 3-wire technique micro switch

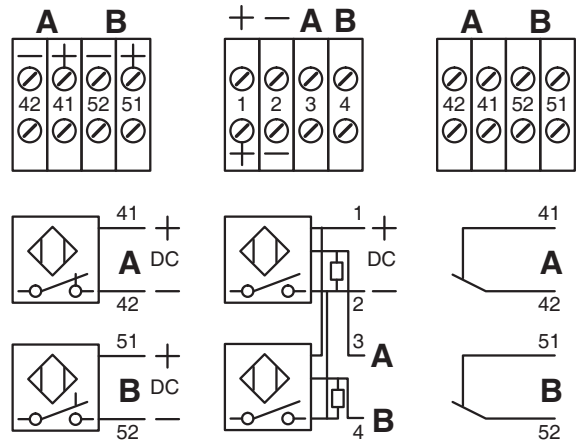

The terminals are suited for cable cross-sections of up to 2.5 mm<sup>2</sup> (fine-strand).

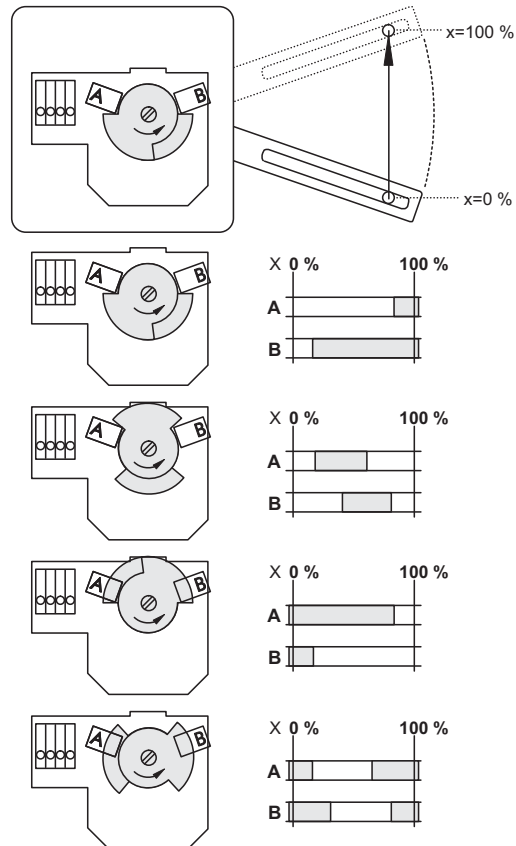

## 8.5 Setting Limit Values

The switching points are dependent on the setting of the control vanes **21**, on the settings of the probes **A** and **B** and on the ratio setting.

To **set the control vanes** loosen the screw **22** on the drive shaft and align the control vanes in accordance with the illustrations on page 23.

During loosening and/or tightening this screw hold control vanes tightly to avoid damaging pinion and tooth segment.

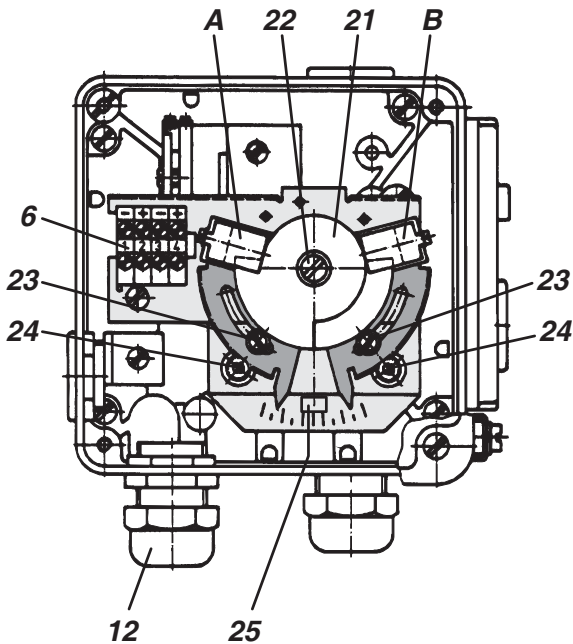

**Adjust the probes** as follows:

- Move the actuator to the position to be signalled
- Loosen locking screw **23** and adjust the switching points by turning adjustment screws **24**.
- Then retighten locking screws.

To **set the transformation** the ratio of the rotation angle of the control vanes can be set continuously by turning the spindle screw **25** of the adapter. Turn clockwise to increase the ratio and counter-clockwise to reduce it.

**Screw on housing cover with the air vent facing downwards when the device is mounted.**

## 8.6 Maintenance

No maintenance is required.

## 8.7 Safety requirements

see page 29

## 8.8 Subsequent installation or exchange

For subsequent installation there are kits available in appropriate versions - see PSS EVE0102A.  
Safety measures indicated in page 29 are to be absolutely observed!

The kit includes the following parts:

- 1** Adapter for transferring the rotary movement to the control vane
- 5** Hexagonal bolts for mounting plate
- 9** Mounting plate with probes, adjusting devices, terminals
- 11** Bolts for housing cover
- 12** Cable fitting
- 13** Screw plug
- 14** Frame with sealing

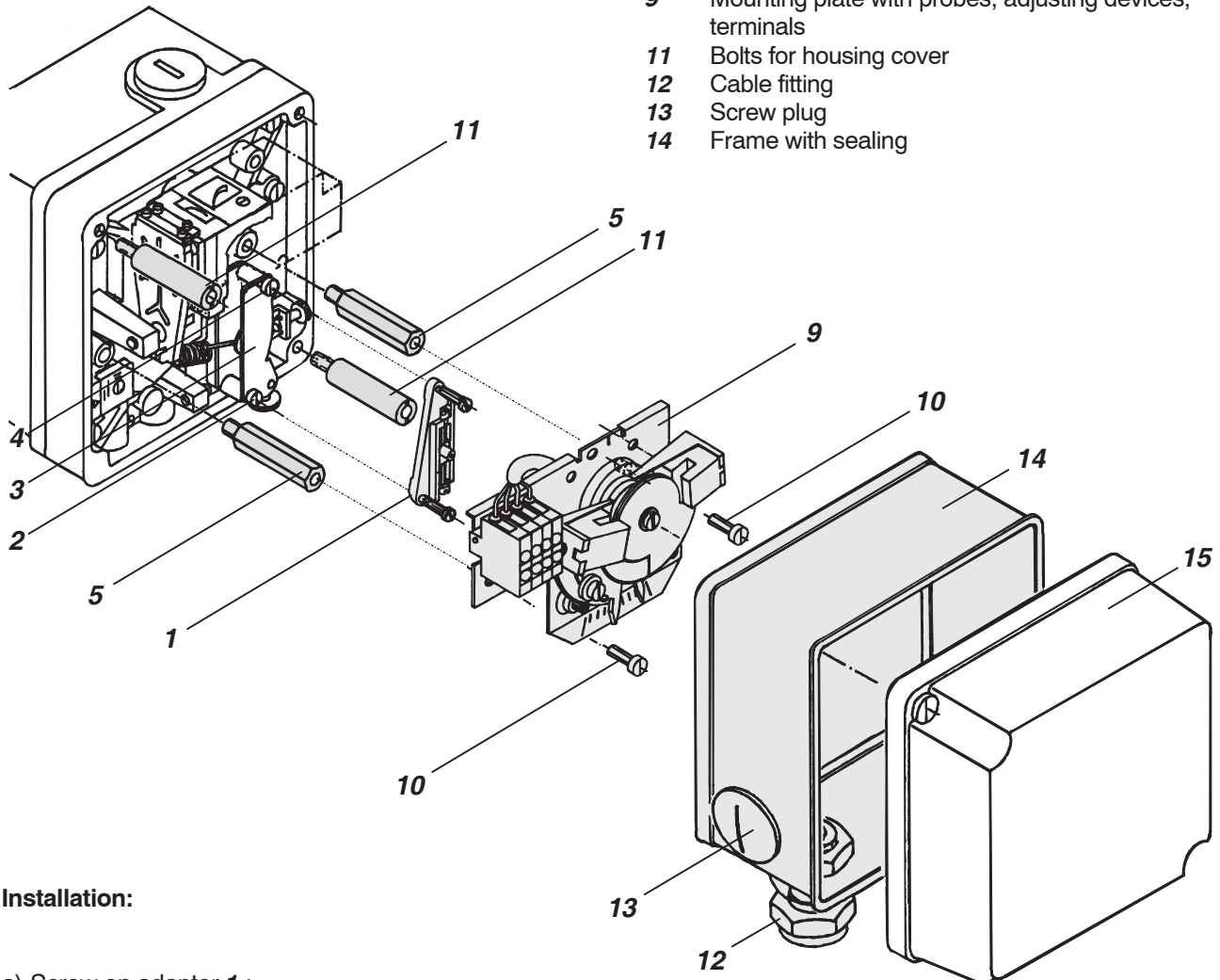

### Installation:

- a) Screw on adapter **1** :  
Unscrew bottom screw **2**. Fit adapter **1**, then screw in the screw again and tighten slightly. Hold adjusting device **3** firmly in position and unscrew top screw **4**. Install adapter **1** and tighten the screw again. Tighten screws **2** and **4**.
- b) Screw in the two hexagonal bolts **5** (SW 8):  
Long hexagonal bolt on the left, short hexagonal bolt on the right.
- c) Screw mounting plate **9** to the two hexagonal bolts **5** with the two screws **10** (if necessary, adjust the adjusting devices so that the right-hand mounting hole is accessible). Be careful to ensure that the driving pin of the adapter engages in the slot in the gear segment.
- d) Screw the two bolts **11** into the female threads to secure the housing cover. When the positioner is installed, these will be the female threads in the top left-hand corner and in the bottom right-hand corner.
- e) Secure cable fitting **12** and screw **13** plug to frame **14** with the enclosed nuts.  
Fit the frame with the rubber seal facing the positioner and cable fitting **12** at the terminals.
- f) Screw on the housing cover with the air vent facing **downwards** when the device is mounted.

## 9 Option “El. Position Transmitter”

The electrical position transmitter is additional equipment either installed in the factory or up-dated. It converts the stroke or rotary movement of an actuator into an electrical standard signal 4 ... 20 mA.

### 9.1 Function

The stroke or rotary angle of an actuator are transmitted to the position controller with a built-in electrical position converter via control lever. The angle setting is converted proportionately into a voltage with a potentiometer. This voltage is converted into the electric standard signal 4 ... 20 mA. Adaption to the stroke of the actuator takes place internally. The start and end of the measuring range are set via 2 push buttons.

### 9.2 Electrical Connections

Grounding cable connection following installation in the SRI986 - see page 14.

### 9.3 Connection layout

The cable is inserted through the M20 x 1.5 cable gland **12** (suitable for lead diameters 6 ... 12 mm) and is connected at the terminal block **6**.

The terminals are suitable for wire cross-sections of up to 2.5 mm<sup>2</sup>.

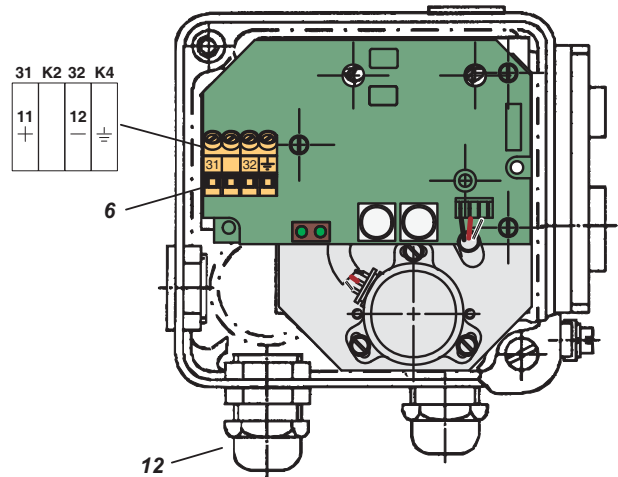
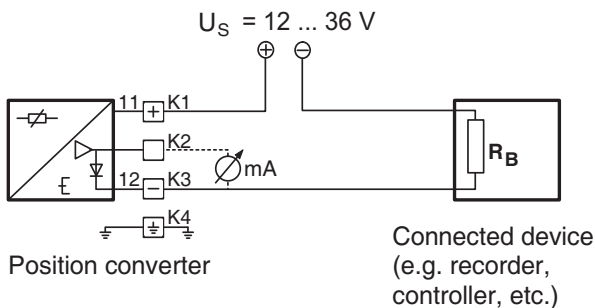

The terminals are connected as follows:

- 31 Auxiliary energy (+)
- K2 Uninterrupted signal current measurement with a low resistance ammeter ( $R_i \leq 10 \text{ Ohm}$ )
- 32 Auxiliary energy (-)
- K4 Protective earth connection

The power supply ( $U_s = 12 \dots 36 \text{ V DC}$ ) originates from the signal circuit in two wire connection.

The maximum permissible load impedance  $R_{Bmax}$  is calculated with the following equation:

$$R_{Bmax} = (U_s - 12 \text{ V}) / 0.02 \text{ A} \quad [\text{Ohm}]$$

$$U_s = \text{Supply voltage in V}$$

### 9.4 Maintenance

No maintenance is required.



## 9.5 Setting and Start Up of position transmitter 4 ... 20 mA

The electronic connection of the position transmitter must be assured. Both LEDs are then light up.

### Adjusting the start of the measuring range (4 mA)

- a) Move the actuator to the starting position.
- b) Press push button S1 "Config Output 4 mA" longer than 2 seconds. During this time LED 1 lights up. After 2 seconds both LEDs are light up again, the value for 4 mA is stored.

### Adjusting the end of the measuring range (20 mA)

- a) Move the actuator to the end position.
- b) Press push button S2 "Config Output 20 mA" longer than 2 seconds. During this time LED 2 lights up. After 2 seconds both LEDs are light up again, the value is stored.

### Random adjustment of the current values at the end points

- a) Move the actuator to the end position, where you want to adjust the current.
- b) Press both buttons simultaneously for about 2 seconds. Then both LEDs are alternating flashing in a slow frequency.
- c) With push button S1 "Config Output 4 mA" the output current value can be decreased and with push button S2 "Config Output 20 mA" the output current value can be increased. Pressing the buttons for a short moment results in a small change and pressing the button for a longer time results in a fast mode for a bigger change. The value of the current can be freely decreased between about 3.3 and increased up to 22.5 mA.
- d) Without any additional manipulations of the push buttons the new value is automatically saved. After a few seconds, the device returns into the normal operating mode, indicated by both LEDs that are then light up again.

## Trouble Shooting of the position transmitter

The components of the position transmitter are under constant surveillance by the installed micro controller. Errors are detected and indicated when both LEDs are off or both LEDs are parallel flashing at a fast frequency.

In the event of a fatal error, e.g. potentiometer not connected, an output current of more than 24 mA will be shown in addition to the error indication given by the LEDs (fast flashing).

In this case check the following:

- a) if the potentiometer is correctly connected to the electronic board.
- b) if the potentiometer is within its working span.

When both LEDs are off, the supply voltage should be checked (minimum tension, polarity).

## 9.6 Subsequent installation or exchange

For subsequent installation there are kits available, see PSS EVE0102A. Safety measures indicated in page 29 are to be absolutely observed!

Kit components:

- 1** Driver plate for transmitting the rotary motion
- 5** Support Ø 7 mm for converter plate
- 9** Converter plate with 2 fillister head screws **10** and one lock washer **20**
- 11** Support for cover
- 12** Cable screw connection
- 13** Screw plug
- 14** Frame with rubber seal

- g) Secure cable screw connection **12** and screw plug **13** to frame **14** using the nuts supplied. Position the frame so that the rubber seal faces towards the position controller and so that the cable screw connection **12** is next to the terminals.
- h) Screw on cover **15** so that the ventilation slot is at the **bottom** when the unit is attached.

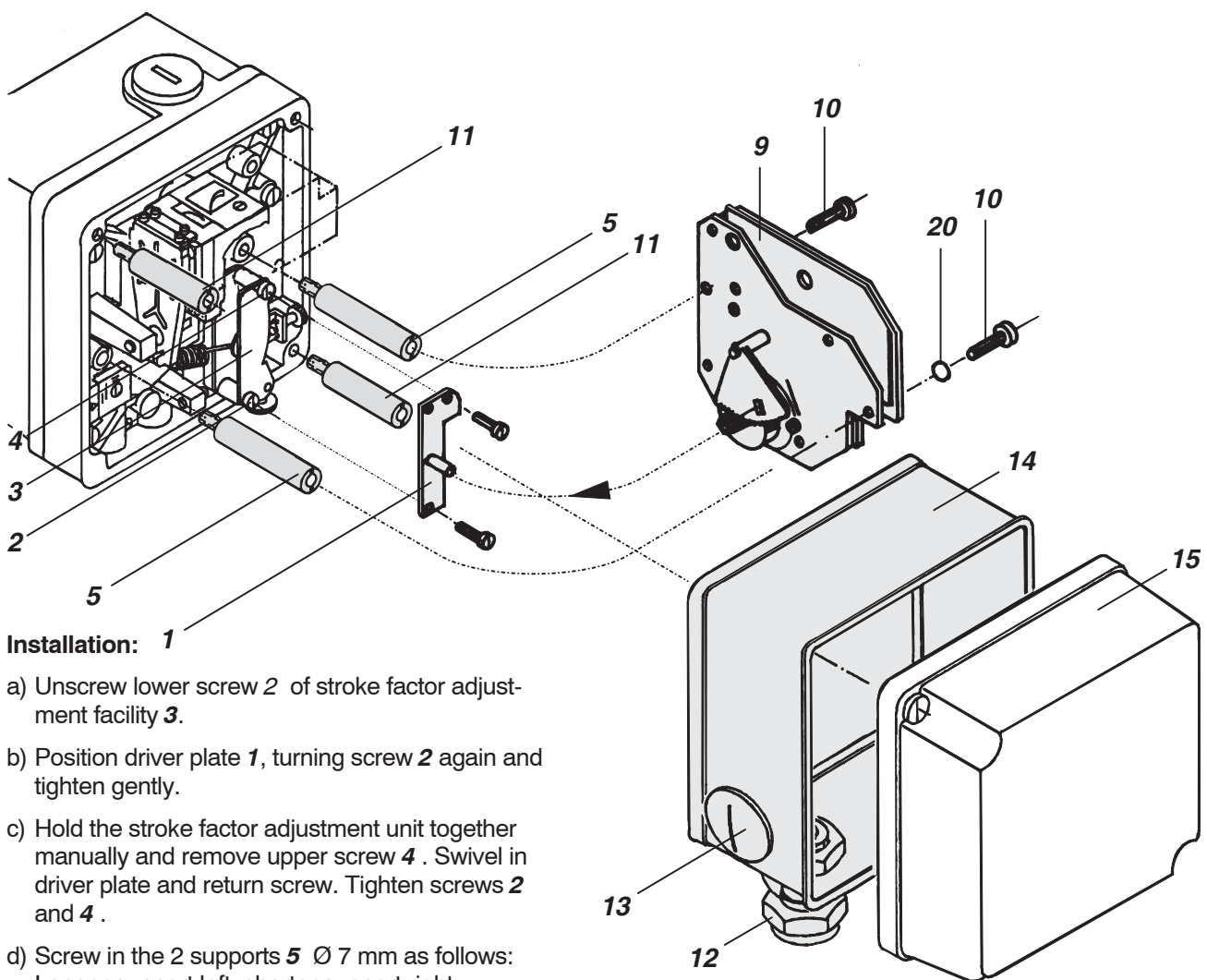

### Installation: 1

- a) Unscrew lower screw **2** of stroke factor adjustment facility **3**.
- b) Position driver plate **1**, turning screw **2** again and tighten gently.
- c) Hold the stroke factor adjustment unit together manually and remove upper screw **4**. Swivel in driver plate and return screw. Tighten screws **2** and **4**.
- d) Screw in the 2 supports **5** Ø 7 mm as follows: Longer support left, shorter support right.
- e) Secure converter plate **9** with screws **10** and a lockwasher **20** (left screw) to the two supports so that the pin on the driver plate **1** engages into the slot on the tooth segment.
- f) Screw two supports **11** into the female thread for securing the cover. In installation position, these are the female threads in the top left corner and in the bottom right corner.

## 10 SAFETY REQUIREMENTS FOR OPTIONS

Repair and maintenance operations with open housing may only be performed by qualified personnel if any voltage sources are connected to the device.

The units must be used for their intended purpose and connected in accordance with the connection diagram. The locally valid national regulations relating to setting up electrical systems must be followed, e.g. in the Federal Republic of Germany DIN VDE 0100 and DIN VDE 0800.

Device may be grounded upon requirement.

The protective measures provided in the units can become ineffective if the unit is not used in accordance with the operation instructions.

### Regulations for Position transmitter

The attachment of the position transmitter with the Id No. EW 420 661 054 and EW 420 661 063 to the positioner is to be regarded as a modification to an explosion-protected unit and is therefore permissible only in accordance with the national legal regulations. The technical design of the kit is the same as that of the certified version of positioners with a built-in option electrical position transmitter.

The following applies to the Federal Republic of Germany: In accordance with § 9 ElexV, the attachment must be certified by an approved expert.

### Regulations for inductive Limit Switch

This device fulfills the requirements stipulated in IEC 1010-1, Class III equipment.

The units may only be operated with safety extra-low voltage SELV oder SELV(E) (functional extra-low voltage with protective separation).

### Regulations for subsequent installation

The attachment of the inductive limit switch to the positioner is to be regarded as a modification to an explosion-protected unit and is therefore permissible only in accordance with the national legal regulations.

The technical design of the kit is the same as that of the certified version of a positioner with a built-in option inductive limit switch Type BIB663 + BIB633 K, PTB-Nr. Ex-87.B.2010.

The following applies to the Federal Republic of Germany: The attachment must be certified by an approved expert as a modification in accordance with § 9 ElexV.

### Regulations for Limit Switch with Micro Switches

This device fulfills the requirements stipulated in IEC 1010-1, Class II equipment, Contamination level 2 and over voltage category II.

## 11 TROUBLESHOOTING

Fault	Possible causes	Remedies
Actuator does not react to the applied input signal nor to a change	Pneumatic connections switched	check connections
	Electrical connections switched	reverse electrical connections
	feedback lever loose	tighten feedback lever
	Positioner mounted on the wrong side	check mounting side see table section 2.2.2
	changeover plate in the wrong position	check position see table in section 2.2.2
	booster defective	Change booster (see page 6)
	I-p converter defective	See note in section 5.3 and proceed accordingly
Output pressure does not reach full value	supply pressure too low	check supply air
	flappers not parallel to nozzles	align flappers (see 5.1 d, e bzw. 5.2 d, e)
	pre-throttle in booster blocked	clean throttle (see 5.4)
	I-p converter defective	see note in section 5.3 and proceed accordingly
	filter in supply connection blocked	change filter
Actuator runs to the end position	positioner mounted on wrong side	check mounting side see table in section 2.2.2
	feedback lever	tighten feedback lever
	Pneumatic connections switched (double-acting version)	check connections
	electrical connections switched	reverse electrical connections
Unstable behavior - positioner circuit oscillates	boost too high	reduce boost (see 4.1)
	gland friction on valve too great	loosen gland slightly or renew
	for piston actuators: static friction on cylinder too great	reduce boost (see 4.1)
	Stroke range cannot be set	range spring unsiutable
	positioner does not exhaust pressure completely	check supply air (max. 6 bar)
		check boost (see 4.1)
		adjust distance between nozzle and flapper (see 5.1 e, f bzw. 5.2 e, f)

**Detail: Nozzles/ flappers system**

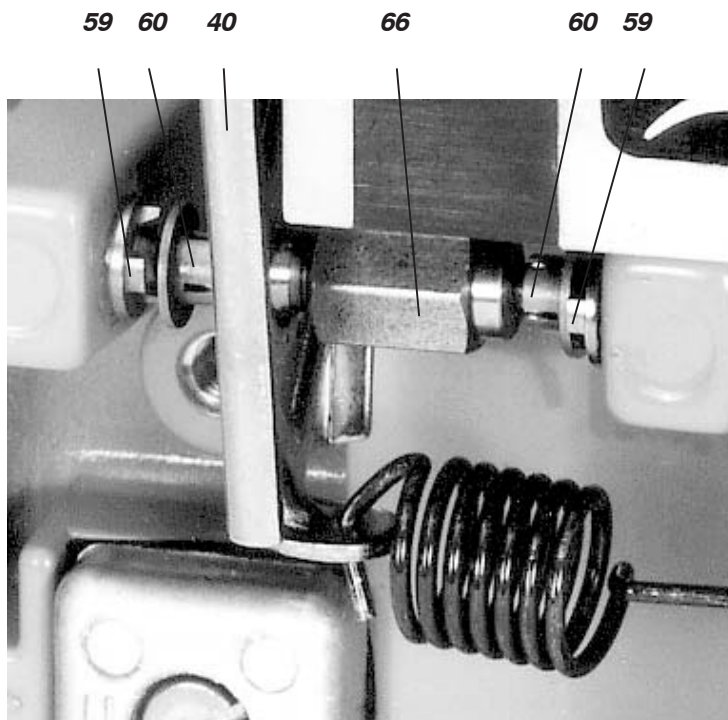

**Single-acting Positioner SRI986**

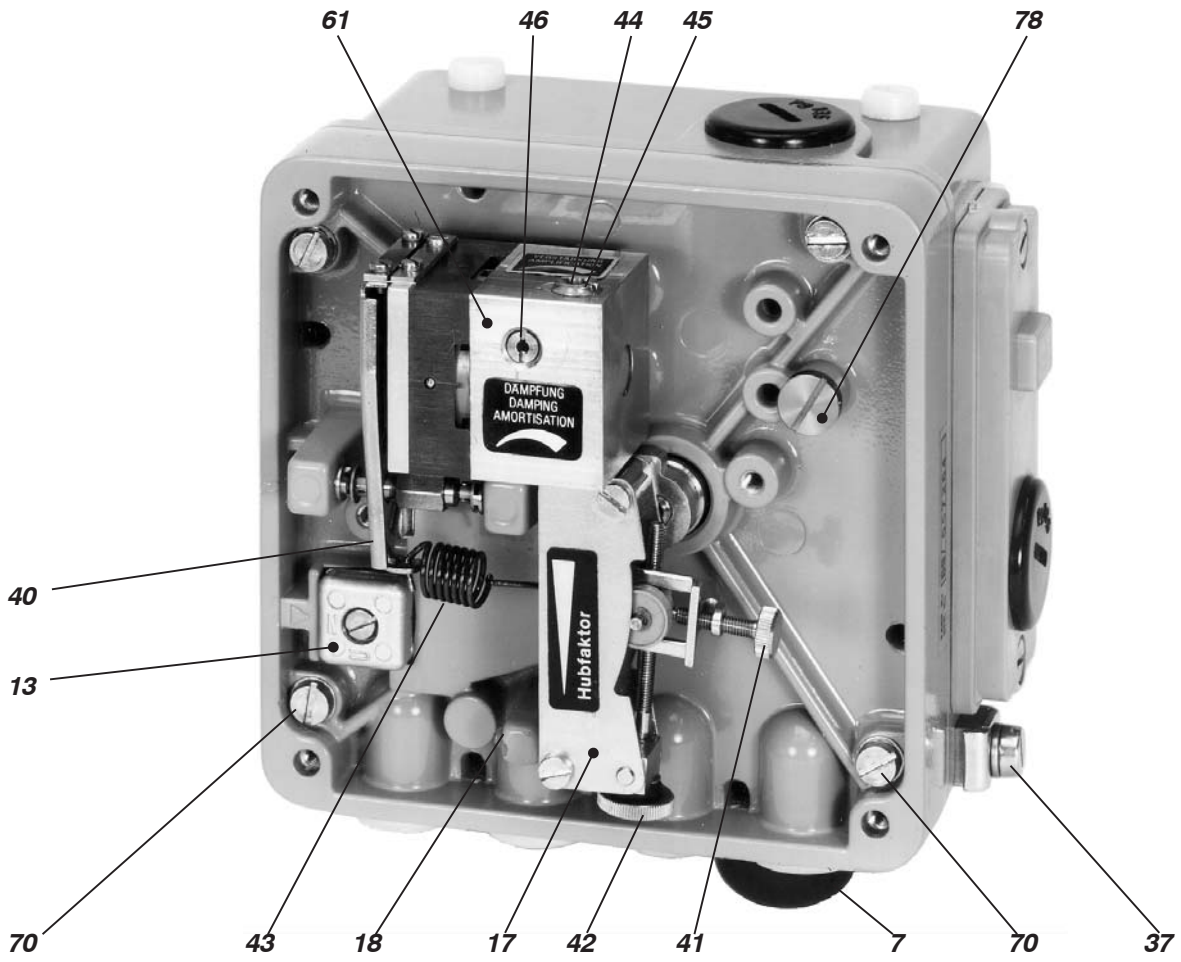

**Double-acting Positioner SRI986**

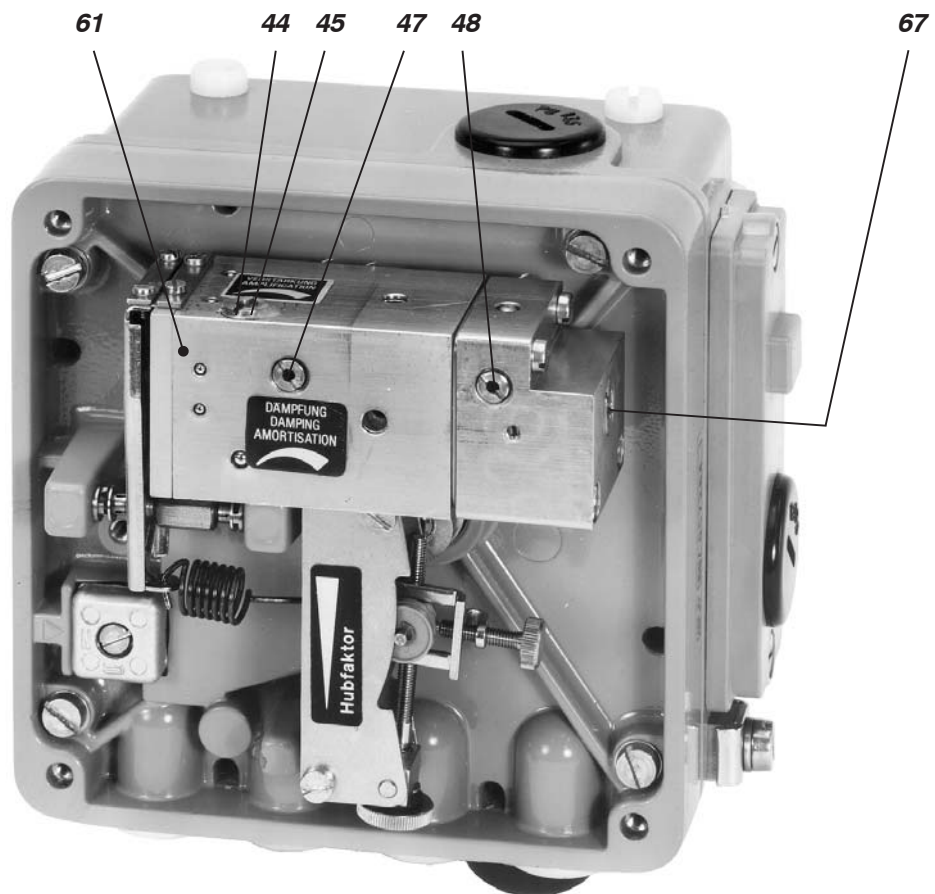

Subject to alterations - reprinting, copying and translation prohibited. Products and publications are normally quoted here without reference to existing patents, registered utility models or trademarks. The lack of any such reference does not justify the assumption that a product or symbol is free.

FOXBORO ECKARDT GmbH  
Postfach 50 03 47  
D-70333 Stuttgart  
Tel. # 49(0)711 502-0  
Fax # 49(0)711 502-597  
<http://www.foxboro-eckardt.com>  
<http://www.foxboro.com/instrumentation>

DOKT 534 043 021