

LR01 Free-Space Radar Level Meter



The LevelWave LR01 is designed to perform continuous level measurement in a wide range of industries and applications. Foxboro Eckardt is known for more than 50 years of experience in level measurement as a leading supplier of extremely robust, durable and reliable level measurements. Unaffected by changes in temperature, specific gravity, pressure and with no need to recalibrate, offering a highly available measurement at low maintenance cost. With the LevelWave LR01 you achieve a highly modular system which is designed for the requirements of the modern industry.

FEATURES

- HART Communication, 4 to 20 mA
- Configuration via FDT-DTM
- Multilingual full text graphic LCD
- 360° rotatable housing with snap solution
- Remote electronics (up to 100 m / 328 ft)
- Display with external keypad
- Measurements down to 1.1 DK possible
- Empty Tank Spectrum (ETS) function
- SIL2-compliant acc. to IEC 61508 for safety related systems
- Measuring range up to 30 m / 98.4 ft
- Housing and cover with bayonet connectors
- Horizontal or vertical housing position
- Continuous self-diagnostics, Status and diagnostic messages, acc. to NE 107
- Local multilingual full graphic LCD, configurable in %, mA or physical units
- Process temperature from -60 to +250 °C
- Process pressure -1 to 40 bar

CONTENTS

1	Product features	3
<hr/>		
1.1	The economic FMCW level Radar	3
1.2	Overview.....	5
1.3	Applications	7
1.4	Antenna selection	8
1.5	Measuring principle.....	9
2	Technical data	11
<hr/>		
2.1	Technical data	11
2.2	Minimum power supply voltage	17
2.3	Pressure ratings	18
2.4	Dimensions and weights	24
3	Installation	31
<hr/>		
3.1	Intended use	31
3.2	Installation	31
3.2.1	Pressure and temperature ranges.....	31
3.2.2	Recommended mounting position	34
3.2.3	Mounting restrictions	36
3.2.4	Standpipes (stilling wells and bypass chambers)	39
4	Electrical connections	43
<hr/>		
4.1	Electrical installation: 2-wire, loop-powered	43
4.1.1	Compact version	43
4.1.2	Remote version	43
4.2	Non-Ex devices	44
4.3	Devices for hazardous locations	45
4.4	Networks	45
4.4.1	General information	45
4.4.2	Point-to-point connection	45
4.4.3	Multi-drop networks	46
5	Order information	47
<hr/>		
5.1	Order code	47
6	Notes	53
<hr/>		

1.1 The economic FMCW level Radar

This device is a non-contact radar level meter that uses FMCW technology. It measures distance, level and volume of liquids and pastes. It is ideal for measuring the level of corrosive products with its PP or PTFE antenna options.

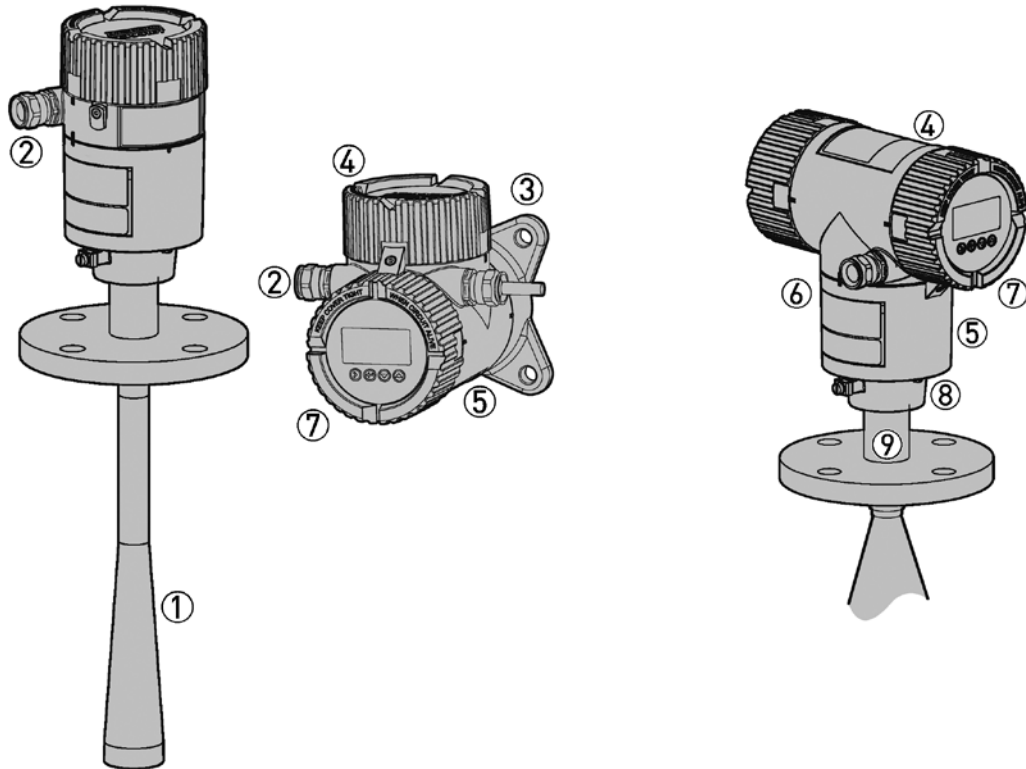

- ① PP or PTFE Wave Horn antennas for the measurement of corrosive products
- ② Optional remote converter can be installed up to 100 m / 328 ft away from the antenna
- ③ Wall support
- ④ Horizontal / vertical housings and antenna options makes the device suitable for many applications and for installation in a variety of positions
- ⑤ Aluminum or stainless steel housing
- ⑥ 2-wire level meter
- ⑦ Optional LCD display with 4-button keypad
- ⑧ Converter is rotatable 360° and removable under process conditions
- ⑨ Dual process seal system

Optional integrated display

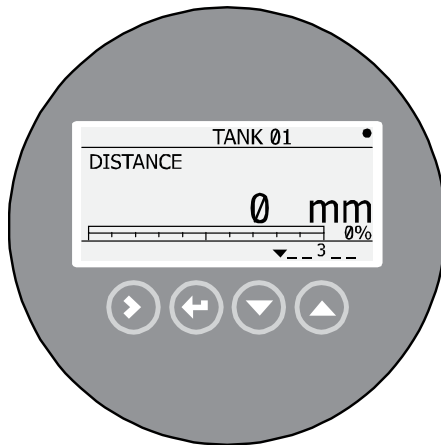

The display can be ordered with the device or as an accessory. It shows measurement data on a 128 × 64 pixel screen. The configuration menu permits the device to be set up in a small number of intuitive steps. Nine languages are available.

Highlights

- PP or PTFE Wave Horn antennas for the measurement of corrosive products
Modular design: horizontal or vertical position of housing is suitable for almost all installations
- Optional local display with an integrated 4-button keypad. It is not necessary to remove the housing cover to get access to the keypad.
- Quick coupling system permits removal of the housing under process conditions and rotation of the housing through 360°
- Bayonet housing cover permits easy opening and closing of the housing, even after years in service
- Measuring range up to 30 m / 98.4 ft
- SIL2-compliant according to IEC 61508 for safety-related systems
- Each device is calibrated on dedicated calibration rigs before it leaves the factory

Industries

- Chemical market
- Oil & Gas
- Power
- Food
- Wastewater
- Metals, Minerals & Mining

Applications

- Storage tanks
- Process tanks
- Open channel flow (if PACTware™ software tool is used)
- River level

1.2 Overview

LevelWave LR01 - Compact / Vertical version

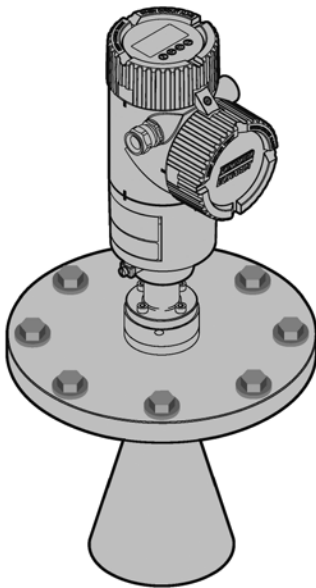

- The converter is vertical. It is attached directly to the process connection (compact version).
- For installation of the device on the ground or in a recess.
- The optional LCD display is attached to the top or the side of the device.

LevelWave LR01 - Compact / Horizontal version



- The converter is horizontal. It is attached directly to the process connection (compact version).
- This version is ideal for installation in areas with low roof clearances.
- For locations where it is easier to read data on the optional LCD display if the converter is in a horizontal position.

LevelWave LR01 - Remote version

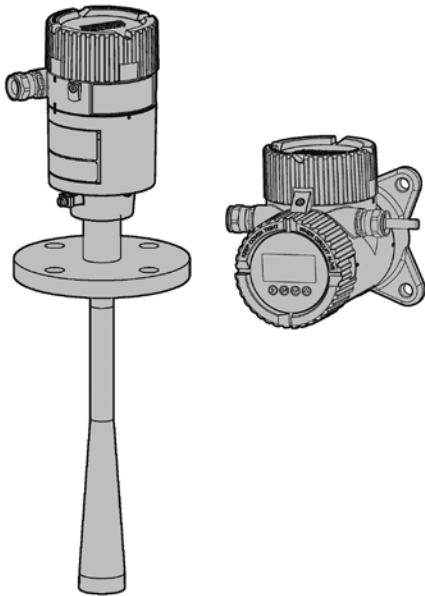

- Users can read measurements and configure the device from the bottom of the tank.
- The remote converter can be installed up to 100 m / 328 ft away from the process connection on the tank.
- Attach the remote converter to a wall, pipe or rigid surface with the supplied wall support.

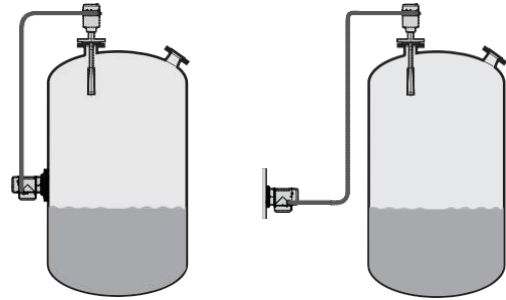

Weather protection

A weather protection option can also be ordered with the device. It is recommended for outdoor applications.



- Must be ordered with the device.
- Can be ordered for both compact versions of the device and the antenna housing of the remote version.
- Easily opened and closed.

1.3 Applications

1. Level measurement of liquids

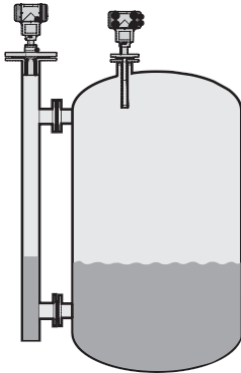

The level meter can measure the level of a wide range of liquid products on a large variety of installations within the stated pressure and temperature range. It does not require any calibration: it is only necessary to do a short configuration procedure.

2. Volume (mass) measurement

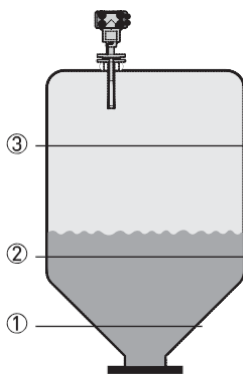

A strapping table function is available in the configuration menu for volume or mass measurement. Up to 30 volume (mass) values can be related to level values. For example:

Level① = 2 m / Volume① = e.g. 0.7 m³

Level② = 10 m / Volume② = e.g. 5 m³

Level③ = 20 m / Volume③ = e.g. 17 m³

This data permits the device to calculate (by linear interpolation) volume or mass between strapping table entries.

3. Flow rate measurement

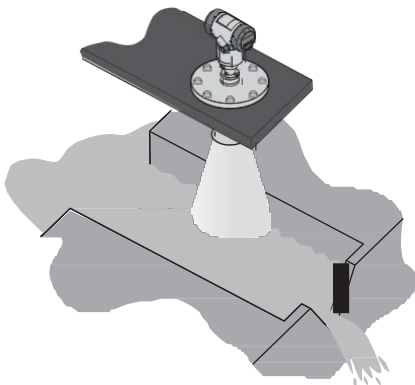

Flow rate measurement is available for field devices that are used with PACTware™ software. A flow rate conversion function is in the DTM supplied with the device. Make a selection from 6 flow profiles: Parshall (ISO 9826), Venturi Rectangular (ISO 4359), Venturi Trapezoidal (ISO 4359), Venturi U (ISO 4359), V-Notch (ISO 1438) or Rectangular Notch (ISO 1438).

1.4 Antenna selection

The graphs below show which antenna to select for the application based on:

- D, the measuring range,
- ϵ_r , is the dielectric constant of the product being measured

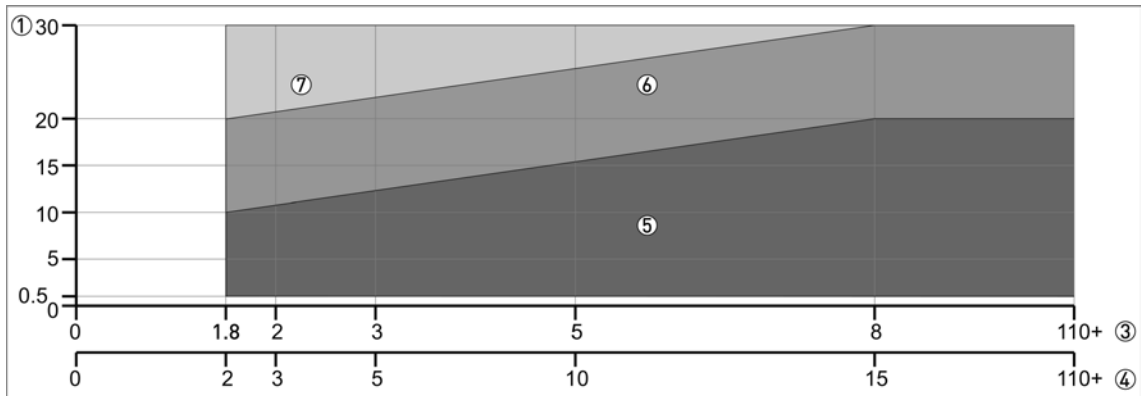

Figure 1-1: Selection of antenna (graph of distance in m against ϵ_r)

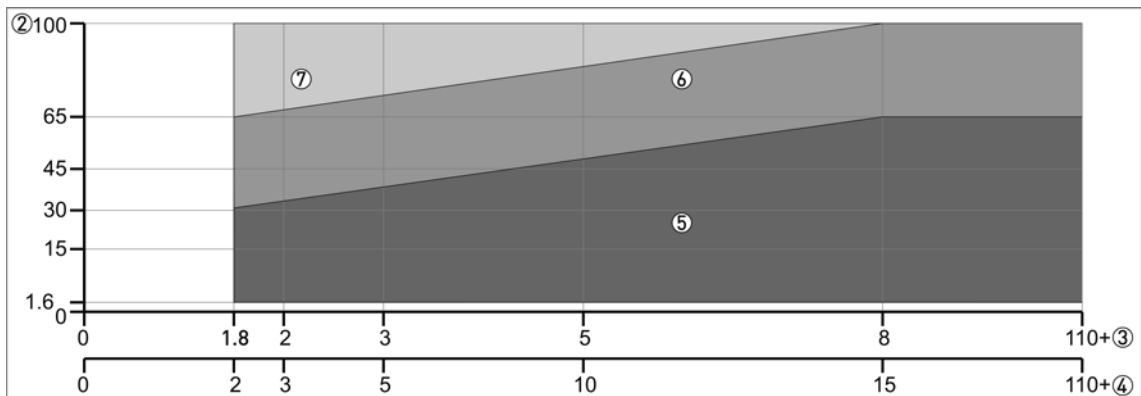

Figure 1-2: Selection of antenna (graph of distance in ft against ϵ_r)

- ① Tank height / Measuring range [m]
- ② Tank height / Measuring range [ft]
- ③ ϵ_r for storage tanks with smooth product surface
- ④ ϵ_r for process tanks without agitator or foam
- ⑤ All antennas:
 - DN80/3" and DN100/4" Metallic Horn antenna: only for use in a stilling well*
 - Wave Guide antenna: maximum measuring range is 6 m / 19.68 ft
- ⑥ DN150/6" or DN200/8" Metallic Horn antennas in a stilling well* or DN200/8" Metallic Horn antenna
- ⑦ DN200/8" Metallic Horn antenna in a stilling well*

* A stilling well is equivalent to the Wave Guide antenna option or a bypass chamber

1.5 Measuring principle

A radar signal is emitted via an antenna, reflected from the product surface and received after a time t . The radar principle used is FMCW (Frequency Modulated Continuous Wave).

The FMCW-radar transmits a high frequency signal whose frequency increases linearly during the measurement phase (called the frequency sweep). The signal is emitted, reflected on the measuring surface and received with a time delay, t . Delay time, $t=2d/c$, where d is the distance to the product surface and c is the speed of light in the gas above the product.

For further signal processing the difference Δf is calculated from the actual transmitted frequency and the received frequency. The difference is directly proportional to the distance. A large frequency difference corresponds to a large distance and vice versa. The frequency difference Δf is transformed via a Fast Fourier Transformation (FFT) into a frequency spectrum and then the distance is calculated from the spectrum. The level results from the difference between tank height and measuring distance.

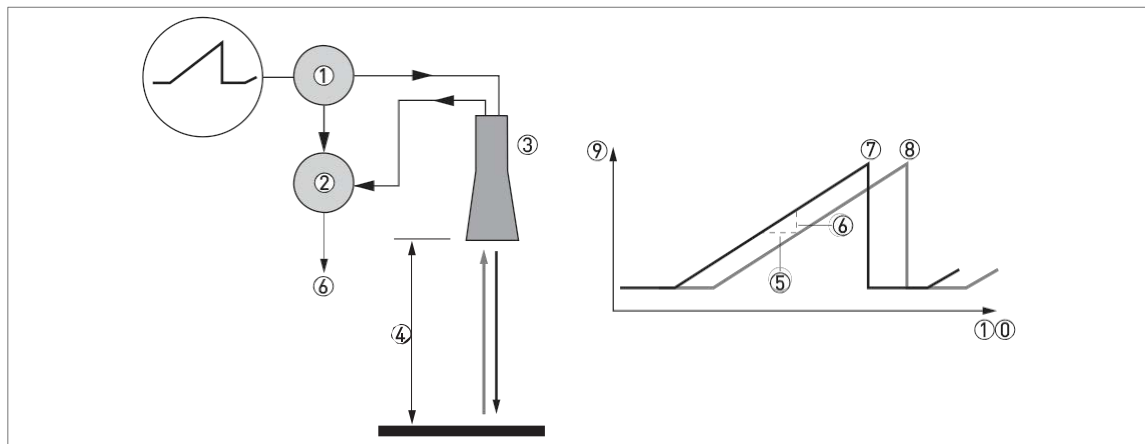

Figure 1-3: Measuring principle of FMCW radar

- ① Transmitter
- ② Mixer
- ③ Antenna
- ④ Distance to product surface, where change in frequency is proportional to distance
- ⑤ Differential time delay, Δt
- ⑥ Differential frequency, Δf
- ⑦ Frequency transmitted
- ⑧ Frequency received
- ⑨ Frequency
- ⑩ Time

Measurement modes

"Direct" mode

If the dielectric constant of the liquid is high ($\epsilon_r \geq 1.8$), the level signal is a reflection on the surface of the liquid.

"TBF Partial" mode

If the dielectric constant of the liquid is low ($\epsilon_r \geq 1.8$, for long distance measurement), you must use "TBF Partial" mode to measure level correctly. TBF Partial" is an automatic mode that lets the device make a selection between "Direct mode and "TBF" mode. If the device finds a large radar reflection above the "tank bottom area" (the bottom 20% of the tank height), the device will use "Direct" mode. If the device finds a large radar reflection in the "tank bottom area", the device uses TBF mode. This mode can be used only in tanks with flat bottoms.

"Full TBF" mode

TBF = Tank Bottom Following. If the dielectric constant of the liquid is very low ($\epsilon_r < 1.8$), you must use "Full TBF" mode to measure level correctly. The device uses the radar reflection on the bottom of the tank (the signal goes through the liquid). This mode can be used only in tanks with flat bottoms.

"FULL TBF" AND "TBF PARTIAL" MODES

It is important to enter the correct dielectric constant value in menu item 2.5.3 Er Product. If not, the device will not measure level accurately.

2.1 Technical data

- The following data is provided for general applications. If you require data that is more relevant to your specific application, please contact us or your local sales office.
- Additional information (certificates, special tools, software,...) and complete product documentation can be downloaded free of charge from our website.

Measuring system

Measuring principle	2-wire loop-powered level transmitter; X-band (10 GHz) FMCW radar
Application range	Level measurement of liquids, pastes and slurries
Primary measured value	Distance and reflection
Secondary measured value	Level, volume, mass and flow rate

Design

Construction	The measurement system consists of a measuring sensor (antenna) and a signal converter
Options	Integrated LCD display (-20..+60°C / -4...+140°F); if the ambient temperature is not in these limits, the display switches off automatically
	High-temperature (HT) extension (if the process connection temperature is more than +150°C / +302°F - Metallic Horn antenna only)
	Straight antenna extensions Max. extension length, PTFE Wave Horn antenna: 300 mm / 11.8"; Max. extension length, Metallic Horn antenna: 1000 mm / 39.4"
	"S" antenna extension - only for DN150/6" and DN200/8" Metallic Horn antenna options
	"L" (right angle) antenna extension - only for DN150/6" and DN200/8" Metallic Horn antenna options
	Antenna purging system - only for DN150/6" and DN200/8" Metallic Horn antenna options
	Heating / cooling system (with or without the antenna purging system) - only for DN150/6" and DN200/8" Metallic Horn antenna options
	Signal cable for remote housing version (refer to cable properties in "Electrical connection: Remote device version")
Weather protection - for the compact version or the antenna housing (remote version). It cannot be ordered after delivery of the device.	
Max. measuring range	PTFE and PP Wave Horn antennas: 20 m / 65.6 ft
	DN80 / DN100 Metallic Horn antennas (installation only in stilling wells): 10 m / 32.8 ft
	DN150 / DN200 Metallic Horn antennas: 30 m / 98.4 ft
	Wave Guide antenna: 6 m / 32.8 ft
	Also depends on the dielectric constant of the product and the installation type. Refer also to "Antenna selection".
Min. tank height	1 m / 3.3 ft
Top dead zone	Minimum value: Antenna length + antenna extension length + 100 mm / 3.9"

Beam angle (½ angle) of antenna	PP Wave Horn: 10°
	PTFE Wave Horn: 10°
	Metallic Horn DN80 / 3": 16° - used only in stilling wells
	Metallic Horn DN100 / 4": 12° - used only in stilling wells
	Metallic Horn DN150 / 6": 8°
	Metallic Horn DN200 / 8": 6°
	Wave Guide / stilling well: n/a - the radar signal is inside the tube.
Display and user interface	
Display	LCD display
	128 x 64 pixels in 8-step grayscale with 4-button keypad
Interface languages	3 language pack options (the language is given in the customer order): ① English, French, German and Italian ② English, French, Spanish and Portuguese ③ English, Chinese (simplified), Japanese and Russian

Measuring accuracy

Resolution	1 mm / 0.04"
Repeatability	±1 mm / ±0.04"
Accuracy	Standard: ±10 mm / ±0.4", when distance < 10 m / 33 ft; ±0.1% of measured distance, when distance > 10 m / 33 ft Option: ±5 mm / ±0.2", when distance < 10 m / 33 ft; ±0.05% of measured distance, when distance > 10 m / 33 ft
Reference conditions acc. to EN 61298-1	
Temperature	+15...+25°C / +59...+77°F
Pressure	1013 mbara ± 50 mbar / 14.69 psia ±0.73 psi
Relative air humidity	60% ±15%
Target	Metal plate in an anechoic chamber

Operating conditions

Temperature	
Ambient temperature	-40...+80°C / -40...+176°F Ex: see supplementary operating instructions or approval certificates
Storage temperature	-50...+85°C / -58...+185°F
Process connection temperature (higher temperature on request)	PP Wave Horn antenna: -20...+100°C / -4...+212°F
	PTFE Wave Horn antenna: -50...+150°C / -58...+302°F
	Metallic Horn antenna / Wave Guide antenna: Standard: FKM/FPM (-40...+150°C (+200°C with an HT extension) / -40...+302°F (+392°F with an HT extension)); Options: Kalrez® 6375 (-20...+150°C (+250°C with an HT extension) / -4...+302°F (+482°F with an HT extension)); PFA (-60°C...+130°C / -76...+266°F); EPDM (-50...+130°C / -58...+266°F) The process connection temperature must agree with the temperature limits of the gasket material. Ex: see supplementary operating instructions or approval certificates①

Pressure	
Process pressure	PP Wave Horn antenna: -1...16 barg / -14.5...232 psig. For more data, refer to Pressure ratings on page 18.
	PTFE Wave Horn antenna: -1...40 barg / -14.5...580 psig. For more data, refer to Pressure ratings on page 18.
	Metallic Horn antenna / Wave Guide antenna: Standard: -1...40 barg / -14.5...580 psig; subject to the process connection used and the flange temperature. Higher pressure on request.
Purging system (option)	Max. 6 barg / 87 psig (higher pressure on request)
Heating / cooling system (option)	Max. 6 barg / 87 psig (higher pressure on request)
Other conditions	
Dielectric constant (ϵ_r)	Direct mode: ≥ 1.8 TBF mode: ≥ 1.1 Refer also to "Technical data: Antenna selection".
Ingress protection	IEC 60529: IP 66/67
	NEMA 250: NEMA type 4X (housing) and type 6P (antenna)
Maximum rate of change	10 m/min / 32.8 ft/min

Installation conditions

Process connection size	The nominal diameter (DN) should be equal to or larger than the antenna diameter.
Process connection position	Make sure that there are not any obstructions directly below the process connection for the device. For more data, refer to Installation on page 31.
Dimensions and weights	For dimensions and weights data, refer to Dimensions and weights on page 24.

Materials

Housing	Standard: Polyester-coated aluminum
	Option: Stainless steel (1.4404 / 316L)
Antenna options / Wetted materials	PTFE Wave Horn antenna with a PTFE flange cladding
	PP Wave Horn antenna with a PP jacket/threaded process connection
	Stainless steel (1.4404 / 316L) Metallic Horn antenna with a PTFE process seal and an FKM/FPM, EPDM, Kalrez [®] 6375 or PFA O-ring gasket
	Stainless steel (1.4404 / 316L) Wave Guide antennas with a PTFE process seal and an FKM/FPM, EPDM, Kalrez [®] 6375 or PFA O-ring gasket
Feed through	PP Wave Horn antenna: this is a single-piece antenna (the feed through is filled with PP)
	PTFE Wave Horn antenna: this is a single-piece antenna (the feed through is filled with PTFE)
	Metallic Horn and Wave Guide antennas: Dual process seal system - 1st seal: PTFE with O-ring gasket , 2nd seal: Metaglas [®] with O-ring gasket ②
Cable gland	Standard: none
	Options: Plastic (Non-Ex: black, Ex i-approved: blue); nickel-plated brass; stainless steel
Weather protection (Option)	Stainless steel (1.4404 / 316L)

Process connections

Thread	PP Wave Horn antenna: G 1½; 1½" NPT
Flange version	
EN	PTFE Wave Horn antenna: DN50...150 in PN16, PN40
	Metallic Horn and Wave Guide antennas: DN80...200 in PN16, PN40; others on request
ASME	PTFE Wave Horn antenna: 2"...6" in 150 lb / 300 lb
	Metallic Horn and Wave Guide antennas: 3"...8" in 150 lb / 300 lb; others on request
JIS	PTFE Wave Horn antenna: 50...150A in 10K
	Metallic Horn and Wave Guide antennas: 80...200A in 10K; others on request
Other	Others on request

Electrical connections

Power supply	Terminals output - Non-Ex / Ex i: 12...30 VDC; min./max. value for an output of 22 mA at the terminal
	Terminals output - Ex d: 16...36 VDC; min./max. value for an output of 22 mA at the terminal
Maximum current	22 mA
Current output load	Non-Ex / Ex i: $R_L [\Omega] \leq ((U_{ext} - 12 \text{ V}) / 22 \text{ mA})$. For more data, refer to Minimum power supply voltage on page 17.
	Ex d: $R_L [\Omega] \leq ((U_{ext} - 16 \text{ V}) / 22 \text{ mA})$. For more data, refer to Minimum power supply voltage on page 17.
Cable entry	Standard: M20x1.5; Option: ½" NPT
Cable gland	Standard: none
	Options: M20x1.5 (cable diameter: 6...10 mm / 0.2...0.39"); others are available on request
Cable entry capacity (terminal)	0.5...2.5 mm ²

Input and output

Output signal	4...20 mA HART [®] or 3.8...20.5 mA acc. to NAMUR NE 43 ③
Resolution	±3 µA
Temperature drift	Typically 50 ppm/K
Digital temperature drift	Max. ±15 mm / 0.6" for the full temperature range
Error signal	High: 22 mA; Low: 3.6 mA acc. to NAMUR NE 43

Approvals and certification

CE	This device fulfils the statutory requirements of the EC directives. The manufacturer certifies successful testing of the product by applying the CE mark.
Vibration resistance	EN 60068-2-64 Metallic Horn (without antenna extension options): 5 Hz to 100 Hz: 4g Metallic Horn, PTFE or PP Wave Horn: 3.5 mm up to 8 Hz and 10 m/s ² : 1g, 8.5 to 2000 Hz
Explosion protection	
ATEX DEKRA 11ATEX0166 X	II 1/2 G, 2 G Ex ia IIC T6...T2 Ga/Gb or Ex ia IIC T6...T2 Gb; II 1/2 D, 2 D Ex ia IIIC T90°C Da/Db or Ex ia IIIC T90°C Db IP6X; II 1/2 G, 2 G Ex d ia IIC T6...T2 Ga/Gb or Ex d ia IIC T6...T2 Gb; II 1/2 D, 2 D Ex ia tb IIIC T90°C Da/Db or Ex ia tb IIIC T90°C Db IP6X
IECEX IECEX DEK 11.0060 X	Ex ia IIC T6...T2 Ga/Gb or Ex ia IIC T6...T2 Gb; Ex ia IIIC T90°C Da/Db or Ex ia IIIC T90°C Db IP6X; Ex d ia IIC T6...T2 or Ex d ia IIC T6...T2 Gb; Ex ia tb IIIC T90°C Da/Db or Ex ia tb IIIC T90°C IP6X
cFMus - Dual Seal-approved	NEC 500 XP-IS / Cl. I / Div. 1 / Gr. ABCD / T6; DIP / Cl. II/III / Div. 1 / Gr. EFG / T6; IS / Cl. I/II/III / Div. 1 / Gr. ABCDEFG / T6; NI / Cl. I / Div. 2 / Gr. ABCD / T6 NEC 505 Cl. I / Zone 0 / AEx d [ia] / IIC / T6; Cl. I / Zone 0 / AEx ia / IIC / T6; Cl. I / Zone 2 / AEx nA [ia] / IIC / T6; Hazardous (Classified) Locations, indoor/outdoor Type 4X and 6P, IP66, Dual Seal CEC Section 18 (Zone ratings) Cl. I, Zone 1, Ex d, IIC (Antenna: Zone 0), T6; Cl. I, Zone 0, Ex ia, IIC, T6; Cl. I, Zone 2, Ex nA, IIC, T6 DIP A21 IP66 TB 95°C CEC Section 18 and Annex J (Division ratings) Cl. I, Div. 1/2, Gr. ABCD; Cl. II, Gr. EFG; Cl. III, T6;
NEPSI	Ex ia IIC T2~T6 DIP A21 T _A IP66; Ex d ia IIC T2~T6 DIP A21 T _A IP66
INMETRO	Ex ia IIC T6...T2 Ga/Gb Ex ia IIIC T90°C Da/Db IP6X Ex d [ia Da] IIC T6...T2 Ga/Gb Ex tb [ia Da] IIIC T90°C Db IP6X

Other standards and approvals	
SIL	Compact version only: SIL 2 - according to EN 61508 and for high/low demand mode operation
EMC	Electromagnetic Compatibility Directive 2004/108/EC in conjunction with EN 61326-1 (2006) SIL 2-approved devices agree with EN 61326-3-1 (2008) and EN 61326-3-2 (2008)
Radio approvals	R & TTE Radio Equipment and Telecommunications Terminal Equipment Directive 1999/5/EC in conjunction with ESTI EN 302 372 (2006)
	FCC Rules Part 15
	Industry Canada RSS-210
LVD	Low-Voltage Directive 2006/95/EC in conjunction with EN 61010-1 (2001)
NAMUR	NAMUR NE 21 Electromagnetic Compatibility (EMC) of Industrial Process and Laboratory Control Equipment
	NAMUR NE 43 Standardization of the Signal Level for the Failure Information of Digital Transmitters
	NAMUR NE 53 Software and Hardware of Field Devices and Signal Processing Devices with Digital Electronics
	NAMUR NE 107 Self-Monitoring and Diagnosis of Field Devices
CRN	This certification is applicable for all Canadian provinces and territories. For more data, refer to the website.
Construction code	Metallic Horn and Wave Guide antennas: NACE MR0175 / ISO 15156; NACE MR0103

- ① If the process connection temperature is more than 150°C / 302°F and the device has Kalrez® 6375 or FKM/FPM gaskets, the device will also have an high temperature extension between the converter and the process connection. Kalrez® is a registered trademark of DuPont Performance Elastomers L.L.C. The process connection temperature must agree with the temperature limits of the gasket material.
- ② Metaglas® is a registered trademark of Herberts Industrieglas, GmbH & Co., KG
- ③ HART® is a registered trademark of the HART Communication Foundation

2.2 Minimum power supply voltage

Use these graphs to find the minimum power supply voltage for a given current output load.

Non-Ex and Hazardous Location approved (Ex i / IS) devices

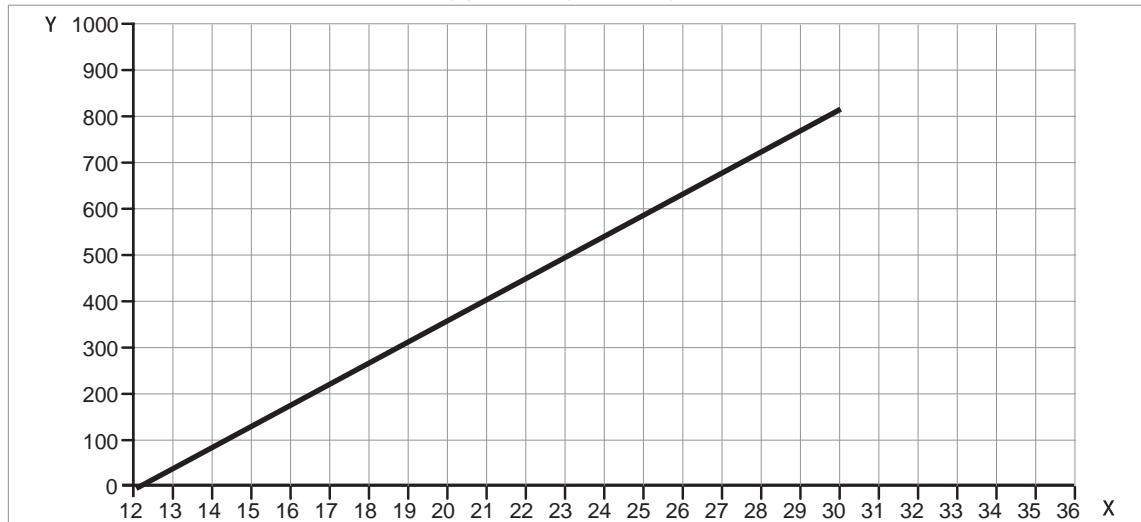

Figure 2-1: Minimum power supply voltage for an output of 22 mA at the terminal (Non-Ex and Hazardous Location approval (Ex i / IS))

X: Power supply U [VDC]
 Y: Current output load R_L [Ω]

Hazardous Location (Ex d / XP / NI) approved devices

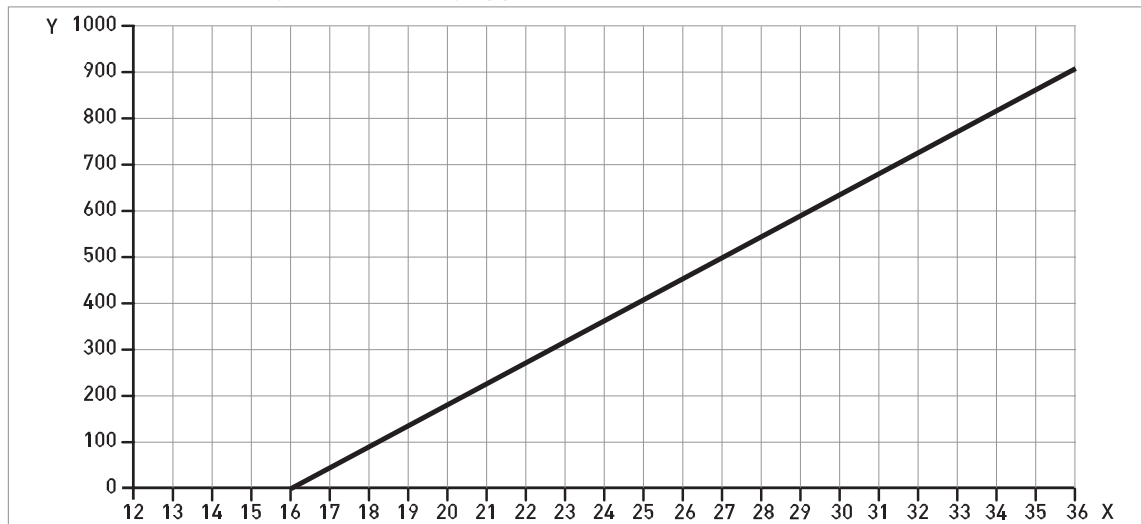

Figure 2-2: Minimum power supply voltage for an output of 22 mA at the terminal (Hazardous Location approval (Ex d / XP / NI))

X: Power supply U [VDC]
 Y: Current output load R_L [Ω]

2.3 Pressure ratings

Make sure that the devices are used within their operating limits.

EN flanges: Metallic Horn, Wave Guide and PTFE Wave Horn antennas

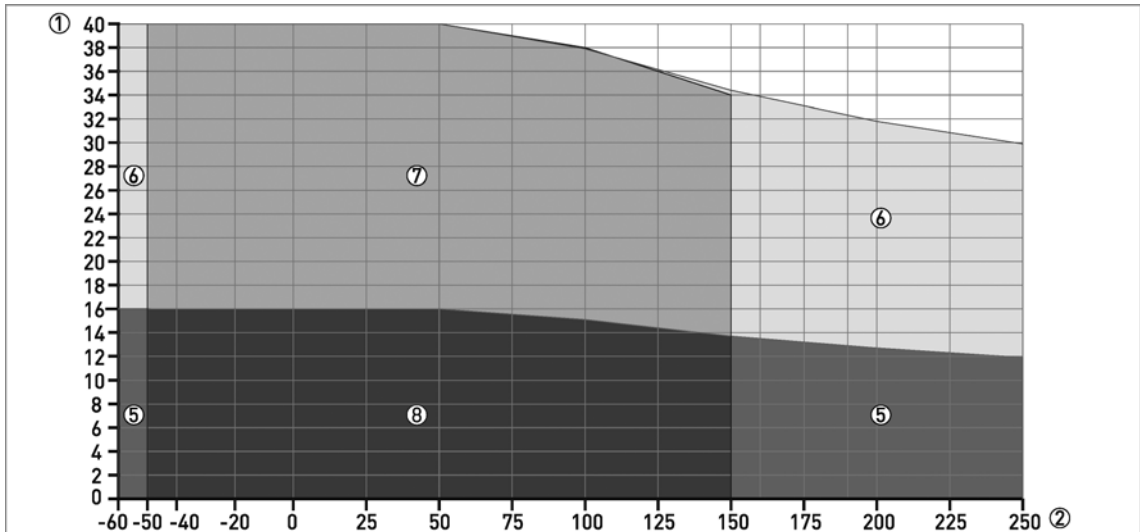

Figure 2-3: Pressure / temperature rating (EN 1092-1), flange connections, in °C and barg

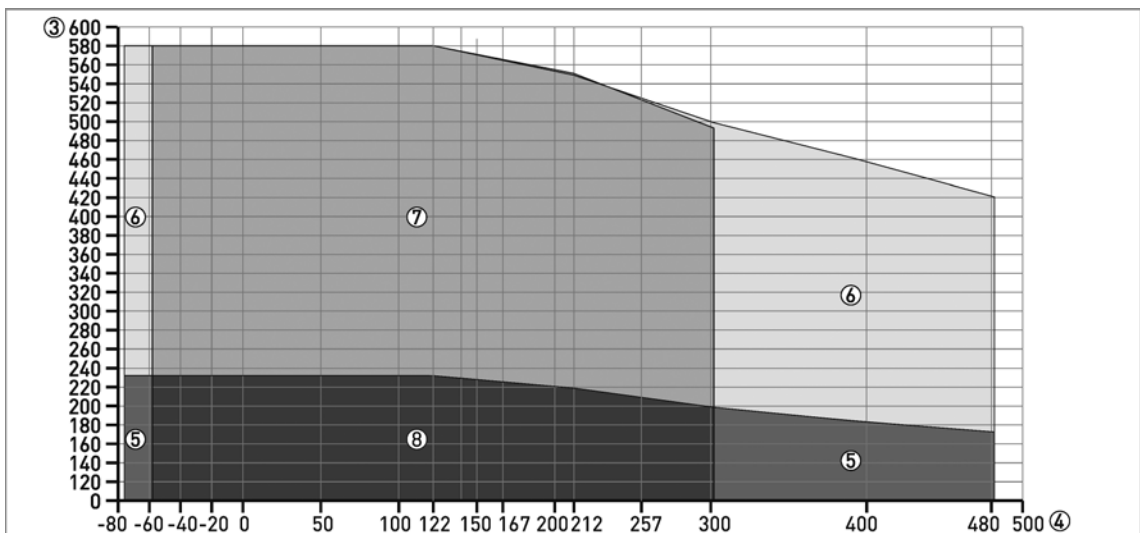

Figure 2-4: Pressure / temperature rating (EN 1092-1), flange connections, in °F and psig

- ① p [barg]
- ② T [°C]
- ③ p [psig]
- ④ T [°F]
- ⑤ Flange connection, PN16: Metallic Horn and Wave Guide antennas
- ⑥ Flange connection, PN40: Metallic Horn and Wave Guide antennas
- ⑦ Flange connection, PN40: Metallic Horn, Wave Guide and PTFE Wave Horn antennas
- ⑧ Flange connection, PN16: Metallic Horn, Wave Guide and PTFE Wave Horn antennas

ISO threaded connections: PP Wave Horn antenna

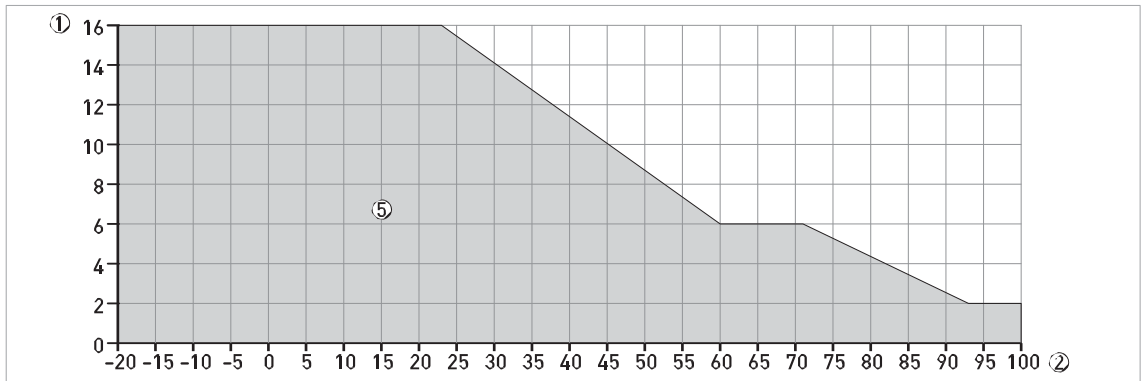

Figure 2-5: Pressure / temperature rating (ISO 228), threaded connection, in °C and barg

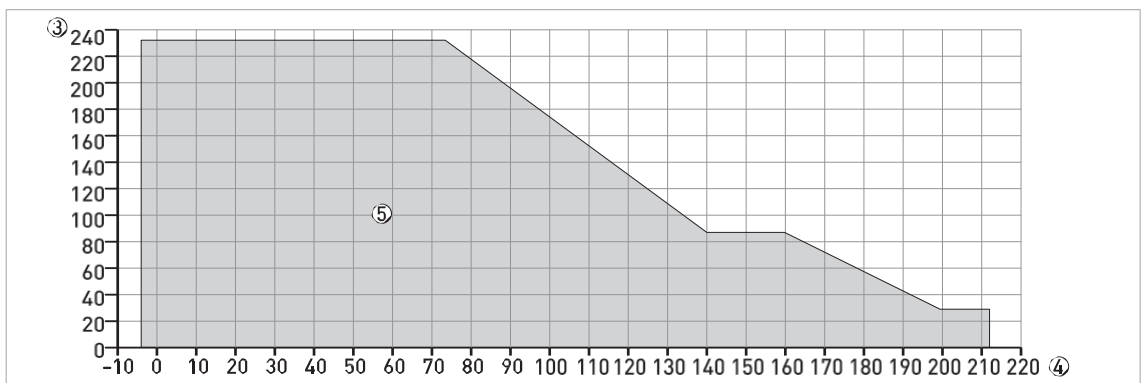

Figure 2-6: Pressure / temperature rating (ISO 228-1), threaded connection, in °F and psig

- ① p [barg]
- ② T [°C]
- ③ p [psig]
- ④ T [°F]
- ⑤ Threaded connection, G (ISO 228-1): PP Wave Horn antenna

ASME flanges: Metallic Horn, Wave Guide and PTFE Wave Horn antennas

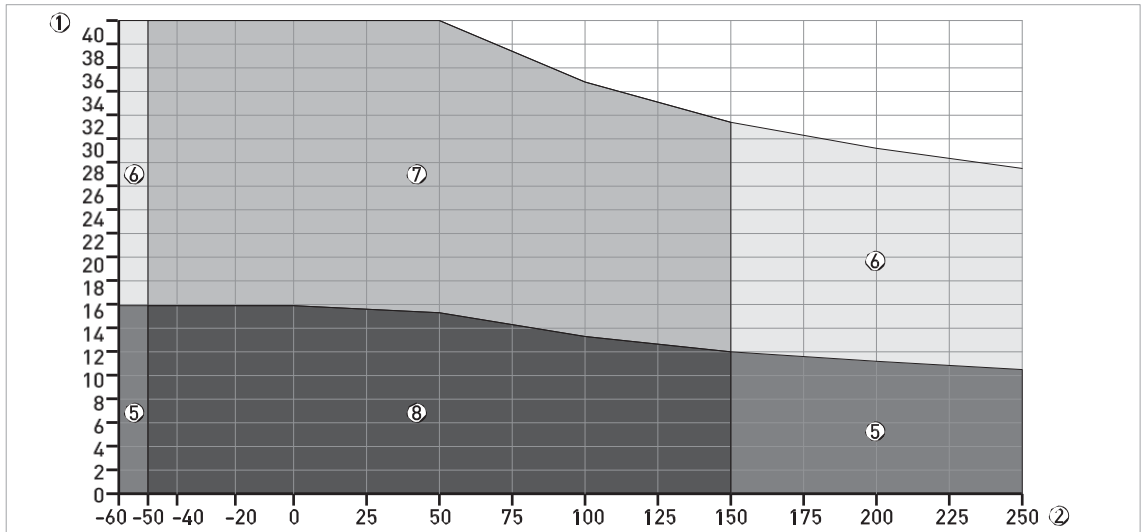

Figure 2-7: Pressure / temperature rating (ASME B16.5), flange and threaded connections, in °C and barg

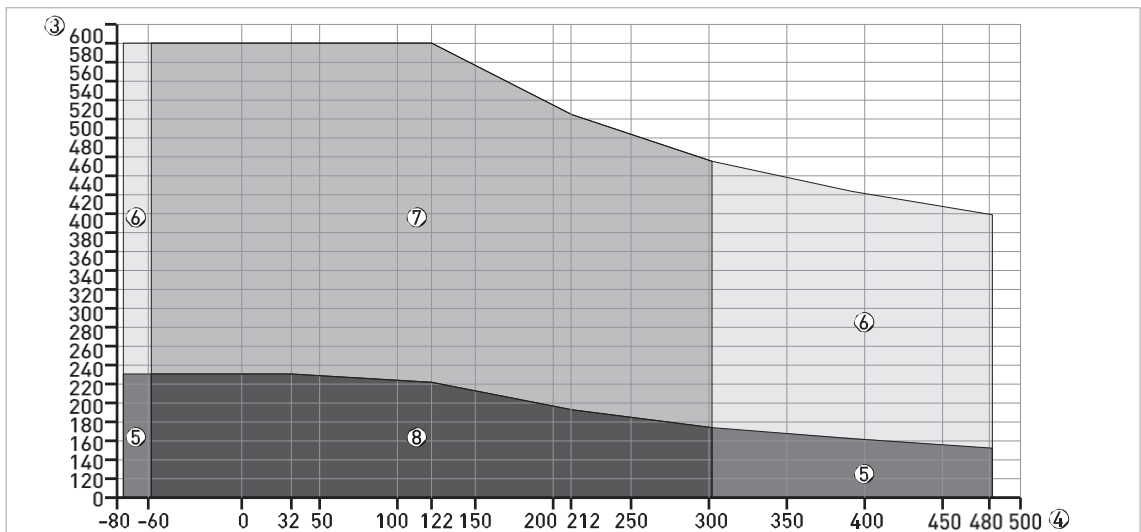

Figure 2-8: Pressure / temperature rating (ASME B16.5), flange and threaded connections, in °F and psig

- ① p [barg]
- ② T [°C]
- ③ p [psig]
- ④ T [°F]
- ⑤ Flange connection, Class 150: Metallic Horn and Wave Guide antennas
- ⑥ Flange connection, Class 300: Metallic Horn and Wave Guide antennas
- ⑦ Flange connection, Class 300: Metallic Horn and Wave Guide and PTFE Wave Horn antennas
- ⑧ Flange connection, Class 150: Metallic Horn and Wave Guide and PTFE Wave Horn antennas

CRN CERTIFICATION

There is a CRN certification option for devices with process connections that agree with ASME standards. This certification is necessary for all devices that are installed on a pressure vessel and used in Canada.

ASME flanges for CRN-approved devices: Metallic Horn, Wave Guide and PTFE Wave Horn antennas

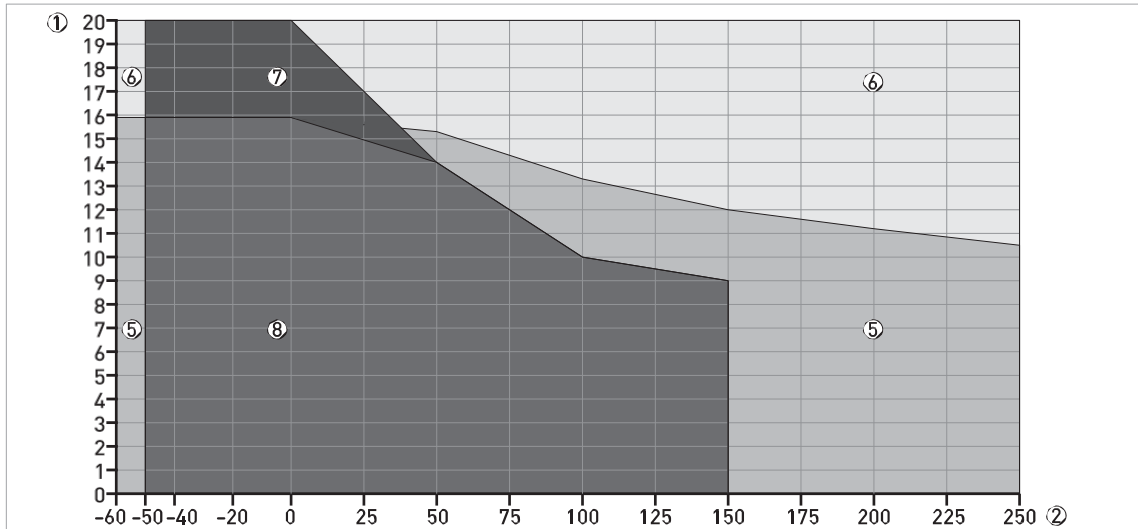

Figure 2-9: Pressure / temperature rating (ASME B16.5), flange and threaded connections, in °C and barg

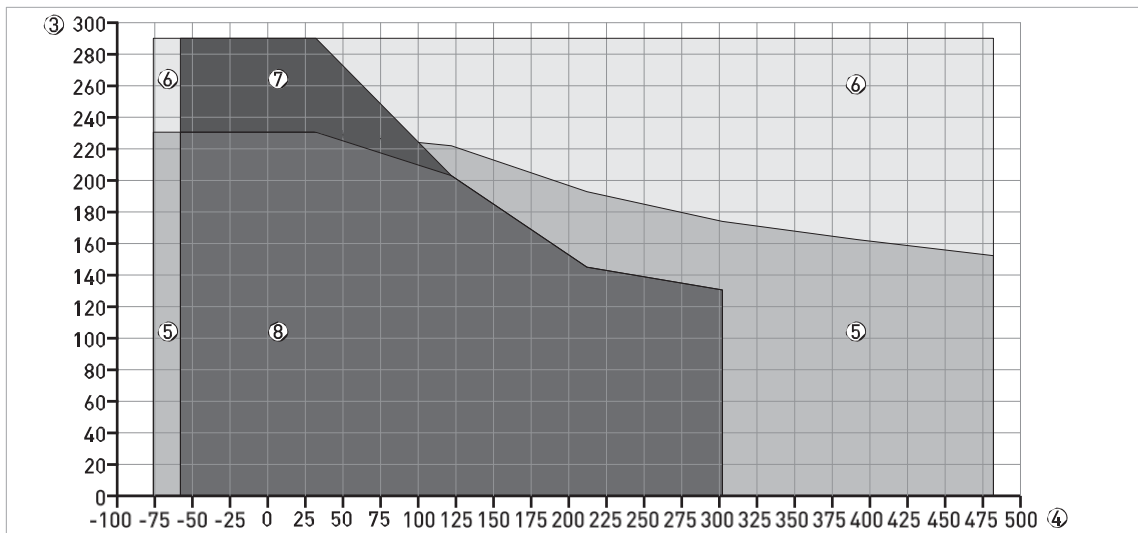

Figure 2-10: Pressure / temperature rating (ASME B16.5), flange and threaded connections, in °F and psig

- ① p [barg]
- ② T [°C]
- ③ p [psig]
- ④ T [°F]
- ⑤ Flange connection, Class 150: Metallic Horn and Wave Guide antennas
- ⑥ Flange connection, Class 300: Metallic Horn and Wave Guide antennas
- ⑦ Flange connection, Class 300: Metallic Horn and Wave Guide and PTFE Wave Horn antennas
- ⑧ Flange connection, Class 150: Metallic Horn and Wave Guide and PTFE Wave Horn antennas

ASME threaded connections: PP Wave Horn antenna

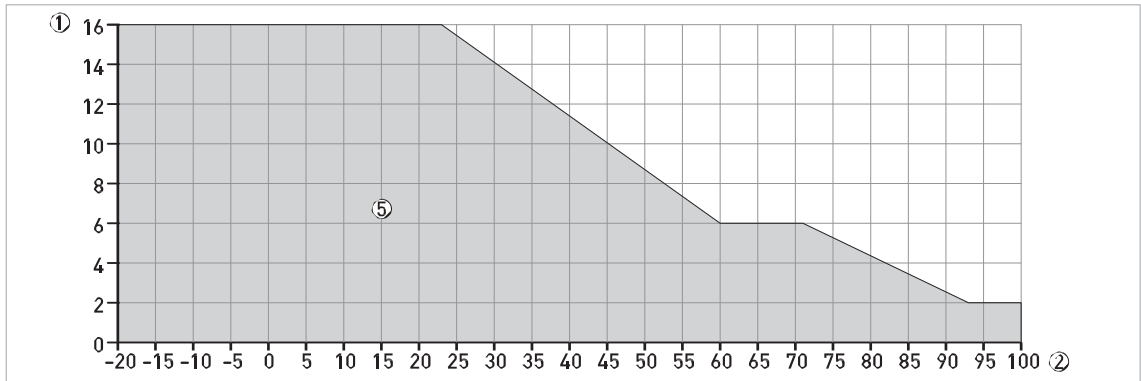

Figure 2-11: Pressure / temperature rating (ASME B1.20.1), threaded connection, in °C and barg

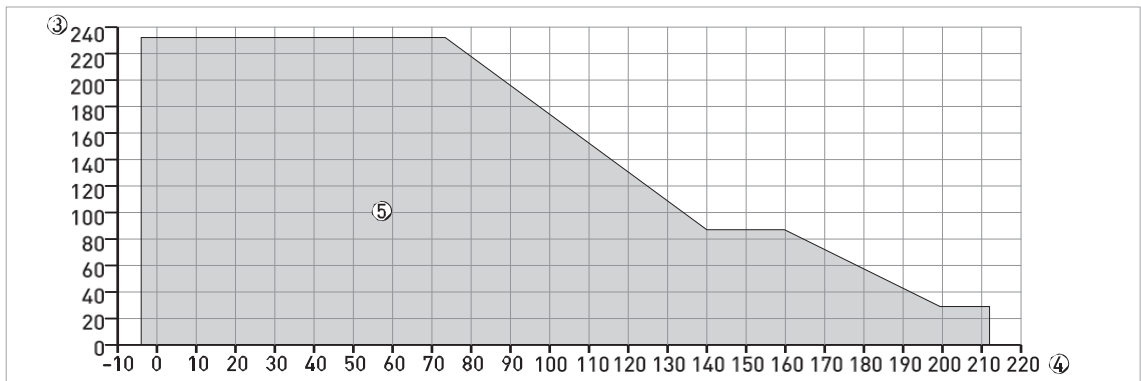

Figure 2-12: Pressure / temperature rating (ASME B1.20.1), threaded connection, in °F and psig

- ① p [barg]
- ② T [°C]
- ③ p [psig]
- ④ T [°F]
- ⑤ Threaded connection, NPT (ASME B1.20.1): PP Wave Horn antenna

CRN CERTIFICATION

There is a CRN certification option for devices with process connections that agree with ASME standards. This certification is necessary for all devices that are installed on a pressure vessel and used in Canada.

ASME threaded connections for CRN-approved devices: PP Wave Horn antenna

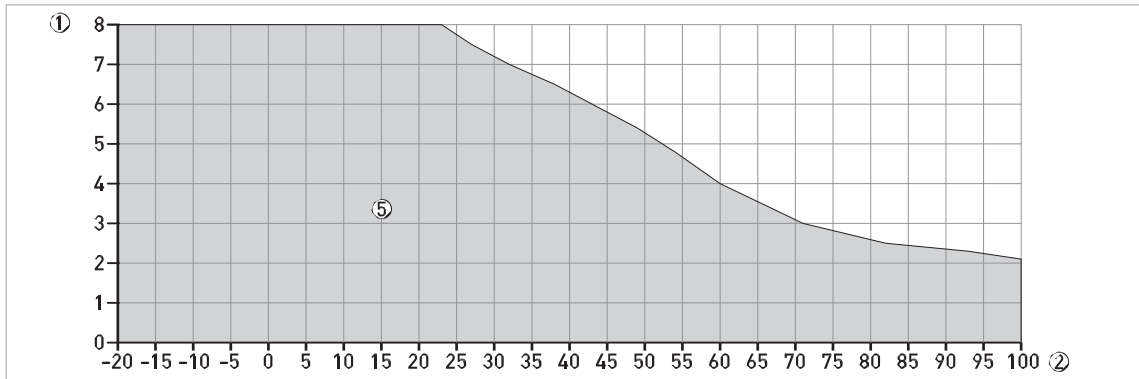

Figure 2-13: Pressure / temperature rating (ASME B1.20.1), threaded connection, in °C and barg

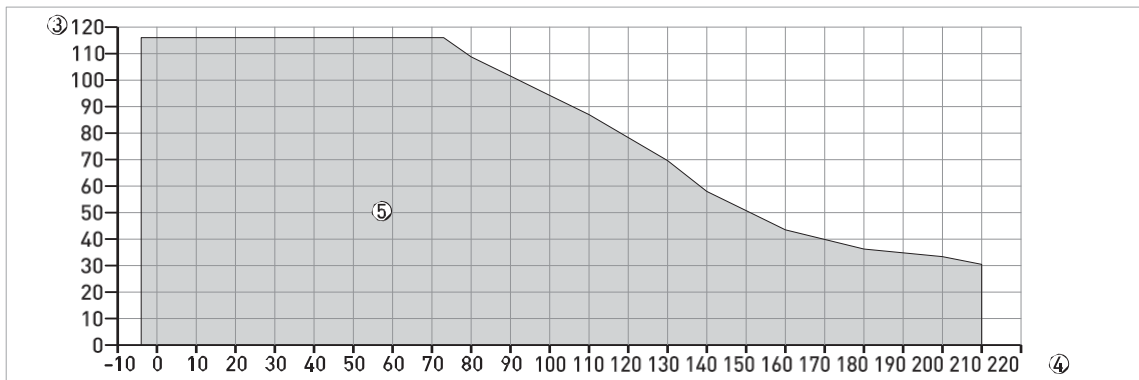

Figure 2-14: Pressure / temperature rating (ASME B1.20.1), threaded connection, in °F and psig

- ① p [barg]
- ② T [°C]
- ③ p [psig]
- ④ T [°F]
- ⑤ Threaded connection, NPT (ASME B1.20.1): PP Wave Horn antenna

2.4 Dimensions and weights

Housing, process connection and antenna options

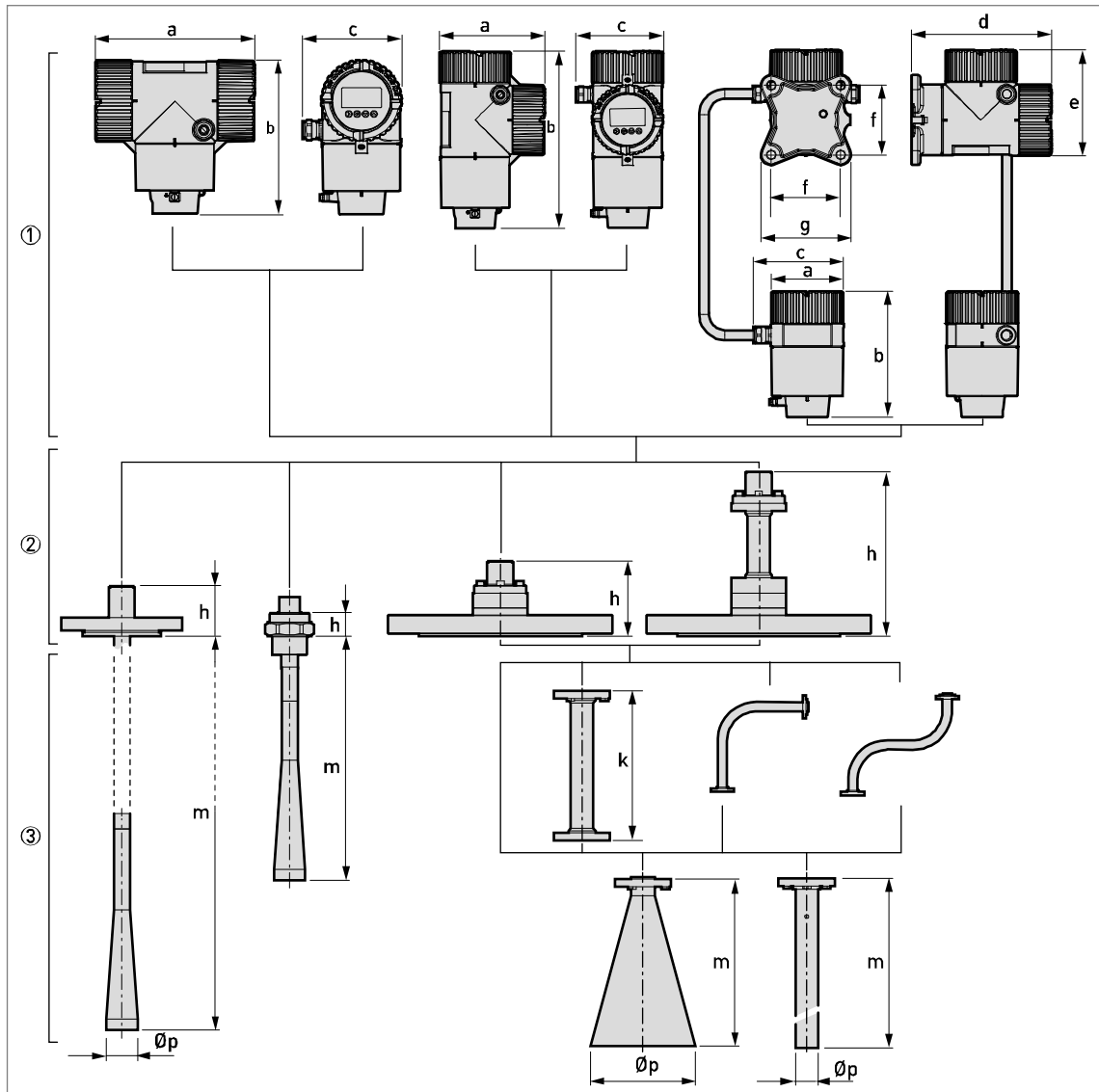

Figure 8-18: Housing, process connection and antenna options

- ① Housing options. From left to right: compact converter with horizontal housing, compact converter with vertical housing, and remote converter (top) and antenna housing (bottom)
- ② Process connection options. From left to right: flange connection for PTFE Wave Horn antenna, threaded connection for PP Wave Horn antenna, flange connection for Metallic Horn and Wave Guide antennas, flange connection with a high-temperature (HT) extension for Metallic Horn and Wave Guide antennas
- ③ Antenna options. From left to right: PTFE Wave Horn antenna, PP Wave Horn antenna, Metallic Horn antenna (with or without an antenna extension option: straight, "L" or "S" extension), Wave Guide antenna

All housing covers have bayonet connectors unless it is an explosion-proof (XP / Ex d-approved) device. The terminal compartment cover for explosion-proof devices has a thread with a flame path.

Housing options: Dimensions in mm and inches

Dimensions	Compact - horizontal		Compact - vertical		Remote	
	Non-Ex or Ex i (Ex d)		Non-Ex or Ex i (Ex d)		Non-Ex or Ex i (Ex d)	
	[mm]	[inches]	[mm]	[inches]	[mm]	[inches]
a	191 (258)	7.5 (10.2)	147 (210)	5.79 (8.27)	104 (104)	4.09 (4.09)
b	214 (214)	8.43 (8.43)	258 (258)	10.16 (10.16)	181 (181)	7.13 (7.13)
c	127 (127)	5.00 (5.00)	127 (127)	5.00 (5.00)	129 (129)	5.08 (5.08)
d	-	-	-	-	184 (184)	7.24 (7.24)
e	-	-	-	-	163 (226)	6.42 (8.90)
f	-	-	-	-	100 (100)	3.94 (3.94)
g	-	-	-	-	155 (155)	6.10 (6.10)

Process connection and antenna options: Dimensions in mm

Dimensions [mm]	PTFE Wave Horn	PP Wave Horn	Metallic Horn				Wave Guide
			DN80 / 3"	DN100 / 4"	DN150 / 6"	DN200 / 8"	
h	68	33	100 (220 for the HT extension) ①				
k	-	-	100, 200, 300, 400, 500, 1000 ②				
m	296 ③	322	112	148.5	223	335	1000...6000
Øp	43	43	80	100	140	200	30

① The HT extension is only for Metallic Horn and Wave Guide antennas. It is attached between the signal converter and the flange if the process connection temperature is +150...+250°C.

② These are the length options for the straight antenna extension. For data about the dimensions of "S" and "L" extensions, refer to the illustrations that follow.

③ Other antenna lengths are available: 396, 496 or 596 mm. These options are for tanks with long nozzles.

Process connection and antenna options: Dimensions in inches

Dimensions [inches]	PTFE Wave Horn	PP Wave Horn	Metallic Horn				Wave Guide
			DN80 / 3"	DN100 / 4"	DN150 / 6"	DN200 / 8"	
h	2.68	1.30	3.94 (8.66 for the HT extension) ①				
k	-	-	3.94, 7.87, 11.81, 15.75, 19.68 or 39.37 ②				
m	11.65 ③	12.68	4.41	5.85	8.78	13.19	39.4...236.2
Øp	1.69	1.69	3.15	3.94	5.51	7.87	1.18

① The HT extension is only for Metallic Horn and Wave Guide antennas. It is attached between the signal converter and the flange if the process connection temperature is +302...+482°F.

② These are the length options for the straight antenna extension. For data about the dimensions of "S" and "L" extensions, refer to the illustrations that follow.

③ Other antenna lengths are available: 15.59", 19.53" or 23.46". These options are for tanks with long nozzles.

Special antenna extensions for tanks with obstructions (DN150 / 6" and DN200 / 8" Metallic Horn antenna options only)

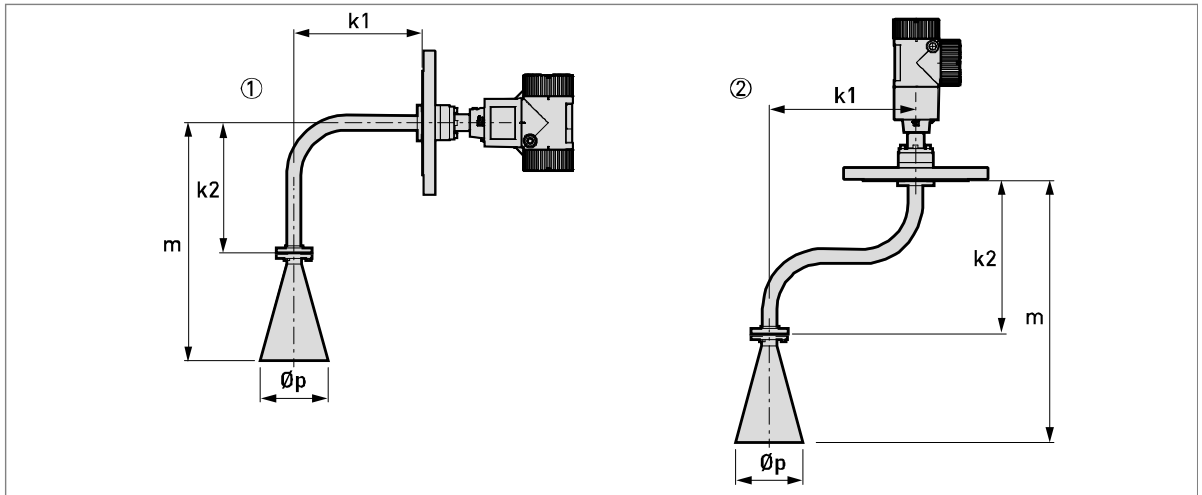

Figure 8-19: Special antenna extensions for tanks with obstructions (DN150 / 6" and DN200 / 8" Metallic Horn antenna options only)

- ① "L" (right angle) antenna extension
- ② "S" antenna extension

Special antenna extensions: Dimensions in mm

Dimensions [mm]	Metallic Horn antenna			
	With "L" (right angle) extension		With "S" extension	
	DN150 / 6"	DN200 / 8"	DN150 / 6"	DN200 / 8"
k1	271		300	
k2	271		322	
m	494	606	545	657
Øp	140	200	140	200

Special antenna extensions: Dimensions in inches

Dimensions [inches]	Metallic Horn antenna			
	With "L" (right angle) extension		With "S" extension	
	DN150 / 6"	DN200 / 8"	DN150 / 6"	DN200 / 8"
k1	10.67		11.81	
k2	10.67		12.68	
m	19.45	23.86	21.46	25.87
Øp	5.51	7.87	5.51	7.87

Purging and heating/cooling system options

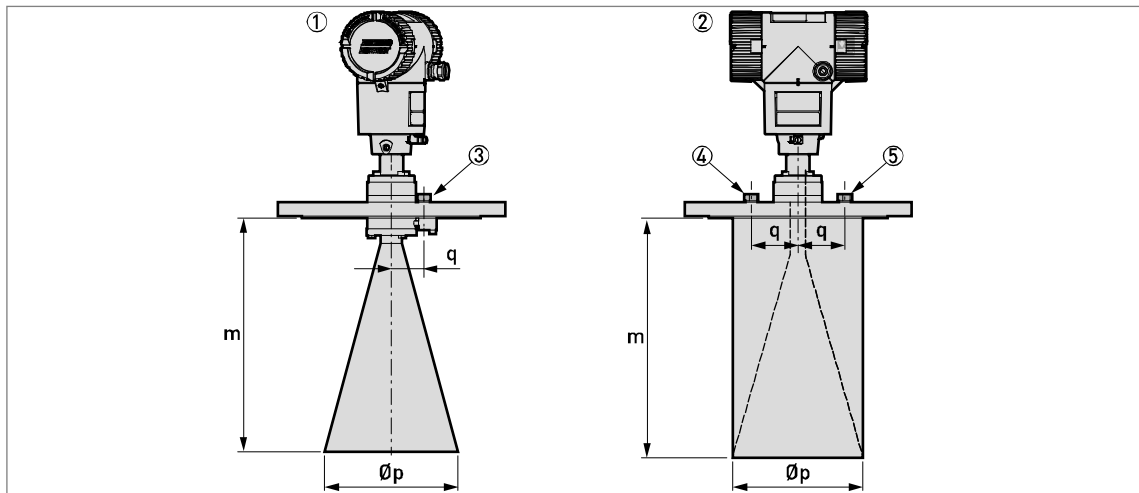

Figure 8-20: Purging and heating/cooling system options

- ① Flange connection with purging option
- ② Flange connection with heating/cooling system option
- ③ G 1/4 threaded connection for purging system (the plug is supplied by the manufacturer)
- ④ G 1/4 threaded connection for the heating/cooling system outlet (the plug is supplied by the manufacturer)
- ⑤ G 1/4 threaded connection for the heating/cooling system inlet (the plug is supplied by the manufacturer)

Purging system and heating/cooling system: Dimensions in mm

Dimensions [mm]	Metallic Horn antenna			
	Purging system		Heating/cooling system	
	DN150 / 6"	DN200 / 8"	DN150 / 6"	DN200 / 8"
m	223	351	202	360 ①
Øp	140	200	139.7	195
q	34	34	53	70

① This is the standard length. Longer on request.

Purging system and heating/cooling system: Dimensions in inches

Dimensions [inches]	Metallic Horn antenna			
	Purging system		Heating/cooling system	
	DN150 / 6"	DN200 / 8"	DN150 / 6"	DN200 / 8"
m	8.78	13.82	8.0	14.17 ①
Øp	5.51	7.87	5.5	7.68
q	1.34	1.34	2.1	2.76

① This is the standard length. Longer on request.

All wetted parts (flange, antenna and heating/cooling jacket) of the heating/cooling system option are made of 316Ti / 1.4571.

Weather protection option

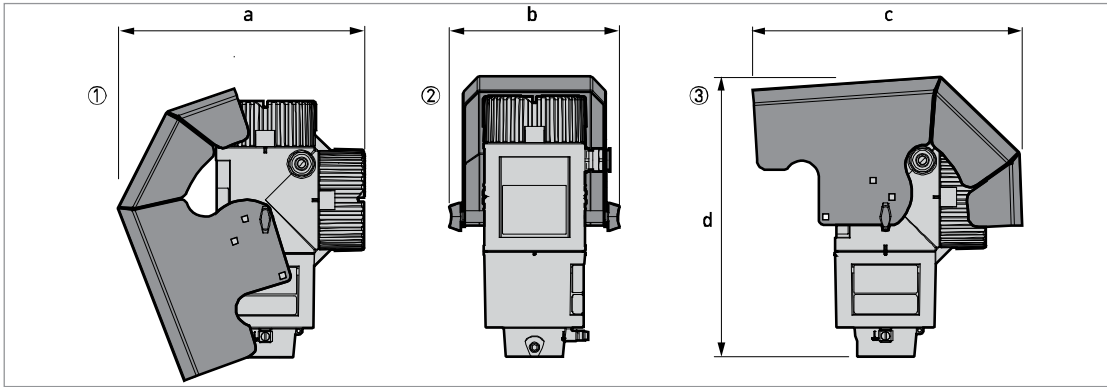

Figure 8-21: Weather protection option for Compact / Vertical and Remote versions

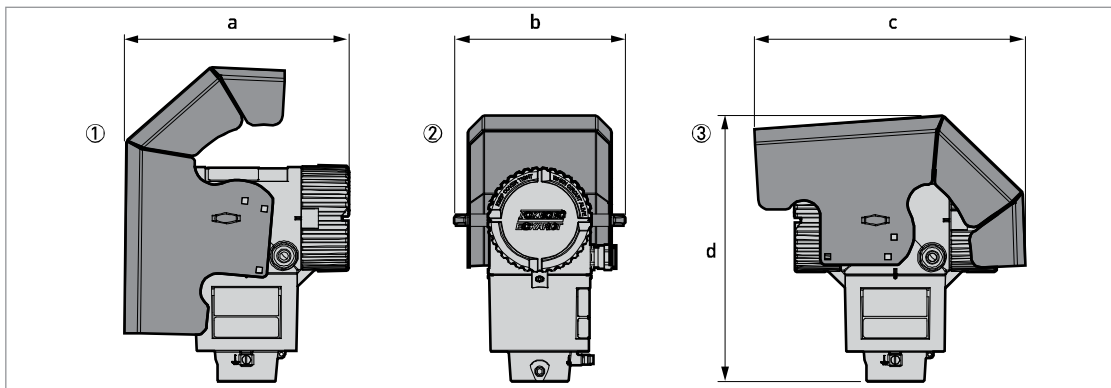

Figure 8-22: Weather protection option for Compact / Horizontal and Remote versions

- ① Left side (with weather protection open)
- ② Rear view (with weather protection closed)
- ③ Right side (with weather protection closed)

Dimensions and weights in mm and kg

Weather protection	Dimensions [mm]				Weights [kg]
	a	b	c	d	
Compact / Vertical or Remote versions	244	170	274	285	1.6
Compact / Horizontal or Remote versions	221	170	274	269	1.6

Dimensions and weights in inches and lb

Weather protection	Dimensions [inches]				Weights [lb]
	a	b	c	d	
Compact / Vertical or Remote versions	9.6	6.7	10.8	11.22	3.5
Compact / Horizontal or Remote versions	8.7	6.7	10.8	10.59	3.5

Converter and antenna housing weights

Type of housing	Weights			
	Aluminum housing		Stainless steel housing	
	[kg]	[lb]	[kg]	[lb]

Non-Ex / intrinsically-safe (Ex i / IS)

Compact	3.0	6.6	6.6	14.6
Remote converter ①	2.5	5.5	5.9	13.0
Antenna housing ①	2.0	4.4	4.1	9.0

Explosion proof (Ex d / XP)

Compact	3.2	7.1	7.5	16.5
Remote converter ①	2.9	6.4	7.1	15.65
Antenna housing ①	2.0	4.4	4.1	9.0

① The remote version of the device has a "remote converter" and an "antenna housing". For more data, refer to "Housing dimensions" at the start of this section.

Antenna option weights

Antenna options	Min./Max. weights	
	[kg]	[lb]

Standard options, without converter

PTFE Wave Horn antenna with flange connection	3.7	8.2
PTFE Wave Horn antenna with flange connection, with 100 mm antenna extension	3.78	8.3
PTFE Wave Horn antenna with flange connection, with 200 mm antenna extension	3.86	8.5
PTFE Wave Horn antenna with flange connection, with 300 mm antenna extension	3.94	8.7
PP Wave Horn antenna with threaded connection	0.7	1.5
DN80 / 3" Metallic Horn antenna with flange connection, standard length	5.6...37.1	12.3...81.8
DN100 / 4" Metallic Horn antenna with flange connection, standard length	9.1...37.2	20.1...82
DN150 / 6" Metallic Horn antenna with flange connection, standard length	13.6...37.5	30...82.7
DN200 / 8" Metallic Horn antenna with flange connection, standard length	14.0...37.8	30.9...83.3
Wave Guide antenna with flange connection, 1...6 m / 3.28...19.68 ft	1.6...9.9	3.5...21.8

Antenna extension options

Straight extension, length 100 mm ①	+0.76	+1.68
Straight extension, length 200 mm ①	+0.94	+2.07
Straight extension, length 300 mm ①	+1.12	+2.47
Straight extension, length 400 mm ①	+1.30	+2.87
Straight extension, length 500 mm ①	+1.48	+3.26
Straight extension, length 1000 mm ①	+2.38	+5.25
"S" extension ①	+1.56	+3.44
"L" (right-angle) extension ①	+1.48	+3.26

Antenna options	Min./Max. weights	
	[kg]	[lb]

Other options

HT extension ②	+0.98	+2.16
----------------	-------	-------

① This option is for Metallic Horn and Wave Guide antenna options

② This component is only for the Metallic Horn and Wave Guide antennas. It is attached between the signal converter and the flange if the process connection temperature is +150...+250°C / +302...+482°F.

3.1 Intended use

This radar level transmitter measures distance, level, mass, volume, flow rate (in open channels) and reflectivity of liquids, pastes and slurries. It does not touch the measured product.

Responsibility for the use of the measuring devices with regard to suitability, intended use and corrosion resistance of the used materials against the measured fluid lies solely with the operator.

The manufacturer is not liable for any damage resulting from improper use or use for other than the intended purpose.

3.2 Installation

3.2.1 Pressure and temperature ranges

If the ambient temperature is more than +70°C / +158°F, there is a risk of injury if you touch the device. Use a protective cover or metallic grid to prevent injury.

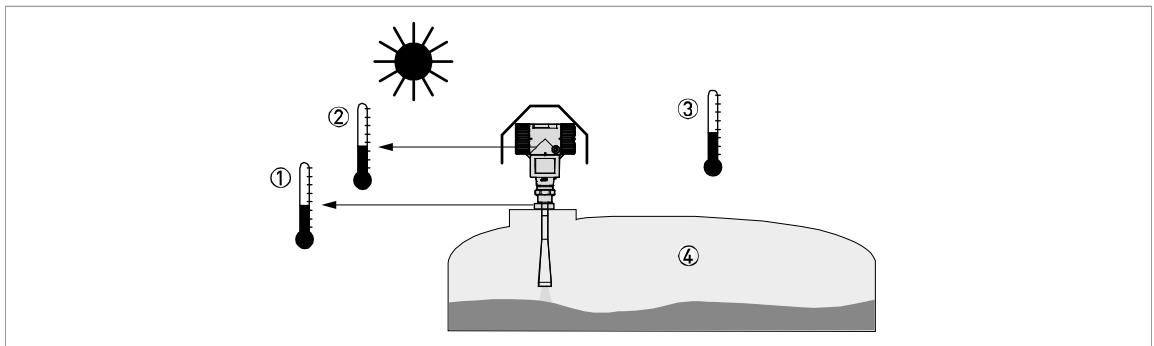

Figure 3-2: Pressure and temperature ranges

- ① Flange temperature
Non-Ex devices: Depends on the type of antenna, process connection and the seal material. Refer to the table that follows.
Ex devices: see supplementary operating instructions
- ② Ambient temperature for operation of the display -20...+60°C / -4...+140°F
If the ambient temperature is not between these limits, the display screen switches off automatically. The device continues to operate.
- ③ Ambient temperature
Non-Ex devices: -40...+80°C / -40...+176°F
Ex devices: see supplementary operating instructions
- ④ Process pressure
Depends on the type of antenna and process connection. Refer to the table that follows.

Antenna type	Process connection	Seal	Process connection temperature		Process pressure	
			[°C]	[°F]	[barg]	[psig]
PP Wave Horn	G 1½; 1½" NPT	-	-20...+100	-4...+212	-1...16	-14.5...232
PTFE Wave Horn	Flange with PTFE plate	-	-50...+150	-58...+302	-1...40	-14.5...580
Metallic Horn Wave Guide	Flange	Metaglas® with FKM/FPM	-40...+200 ①	-40...+392 ①	-1...40 ②	-14.5...580 ②
		Metaglas® with Kalrez® 6375	-20...+250 ①	-4...+482 ①	-1...40 ②	-14.5...580 ②
		Metaglas® with PFA	-60...+130 ①	-76...+266 ①	-1...40 ②	-14.5...580 ②
		Metaglas® with EPDM	-50...+130 ①	-58...+266 ①	-1...40 ②	-14.5...580 ②

① Higher temperature on request

② Higher pressure on request

For more data on pressure ratings, refer to Pressure ratings on page 18

Ambient temperature / flange temperature, flange and threaded connection, in °C

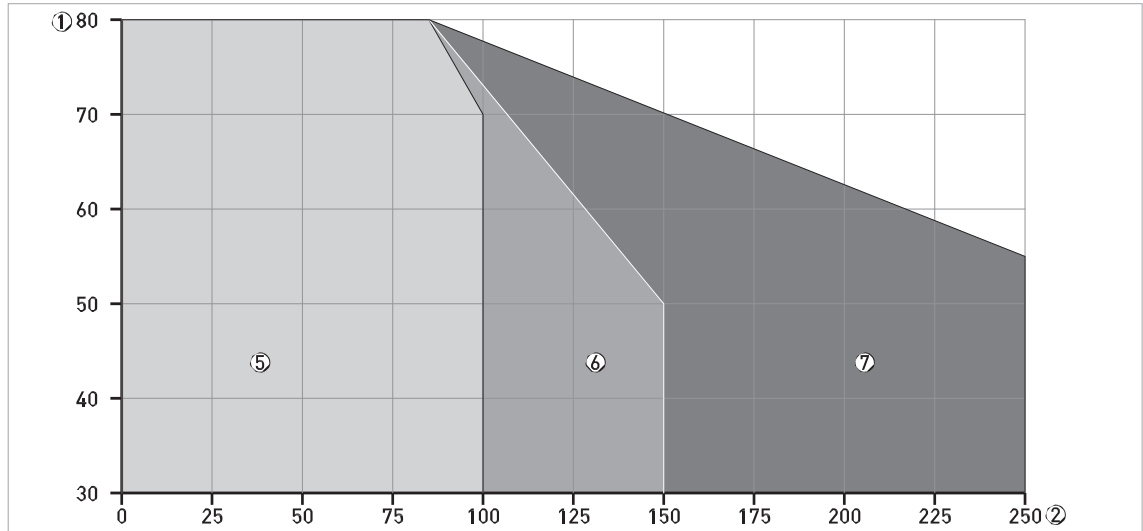

Figure 3-2: Ambient temperature / flange temperature, flange and threaded connection, in °C

Ambient temperature / flange temperature, flange and threaded connection, in °F

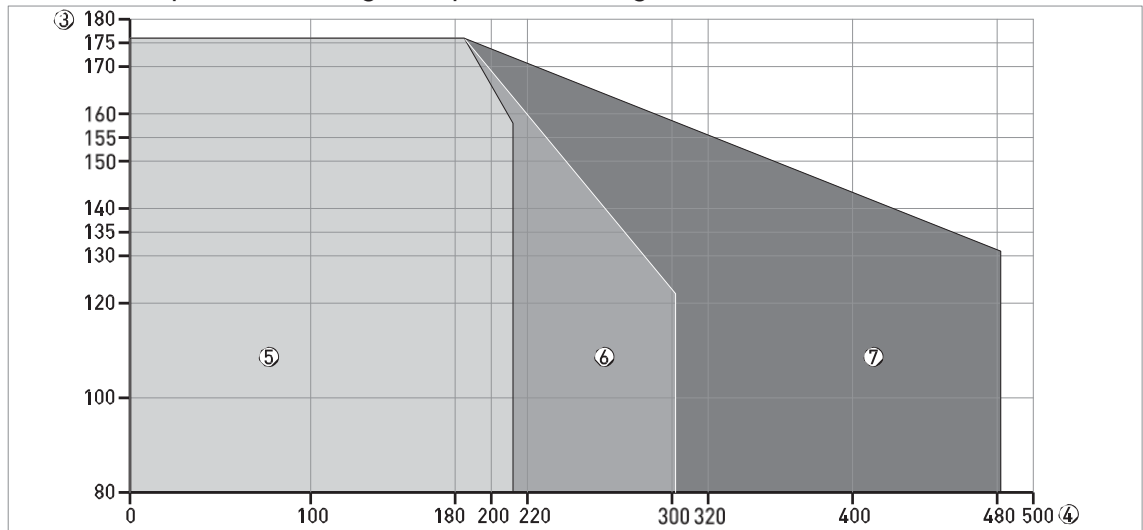

Figure 3-3: Ambient temperature / flange temperature, flange and threaded connection, in °F

- ① Maximum ambient temperature, °C
- ② Maximum flange temperature, °C
- ③ Maximum ambient temperature, °F
- ④ Maximum flange temperature, °F
- ⑤ PP Wave Horn antenna
- ⑥ PTFE Wave Horn antennas. Metallic Horn and Wave Guide antennas (standard temperature version).
- ⑦ Metallic Horn and Wave Guide antennas (high temperature version)

There is no change (de-rating) in ambient temperature below 0°C / 0°F. The process connection temperature must agree with the temperature limits of the gasket material. For pressure rating data, refer to Pressure ratings on page 18.

3.2.2 Recommended mounting position

Follow these recommendations to make sure that the device measures correctly. They have an effect on the performance of the device.

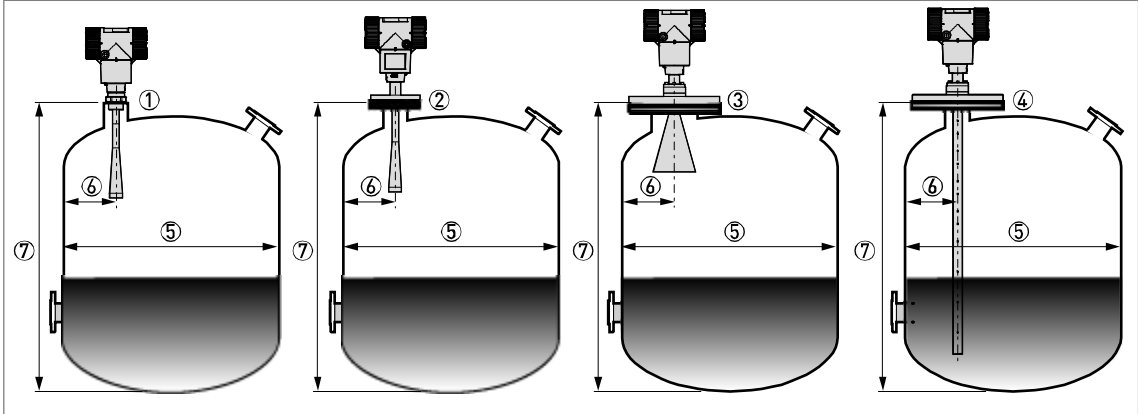

Figure 3-5: Recommended mounting position for liquids, pastes and slurries

- ① Sockets for the PP Wave Horn antenna
- ② Nozzles for the PTFE Wave Horn antenna
- ③ Nozzles for DN150 or DN200 Metallic Horn antennas
- ④ Nozzles for Wave Guide antennas
- ⑤ Tank diameter
- ⑥ Minimum distance of the nozzle or socket from the tank wall (depends on the antenna type and size - refer to items ①, ②, ③ and ④ in this list):
 - PP/PTFE Wave Horn (① and ②): $1/7 \times$ tank height
 - Metallic Horn (③): $1/10 \times$ tank height
 - Wave Guide (④): There is no minimum distance from the Wave Guide antenna to metallic walls and other metal objects
- Maximum distance of nozzle from the tank wall (depends on the antenna type and size - refer to items ①, ② and ③ in this list):
 - PP/PTFE Wave Horn (① and ②): $1/3 \times$ tank diameter
 - Metallic Horn (③): $1/3 \times$ tank diameter
 - Wave Guide (④): There is no maximum distance from the Wave Guide antenna to metallic walls and other metal objects
- ⑦ Tank height

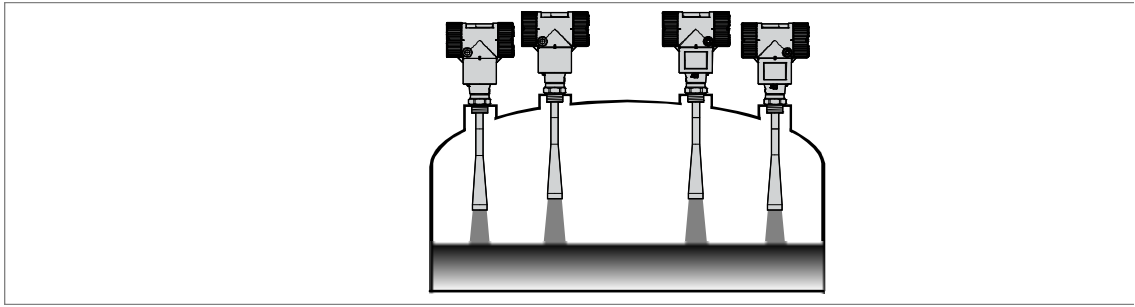

Figure 3-7: A maximum of 4 FMCW radar level meters can be operated in a tank

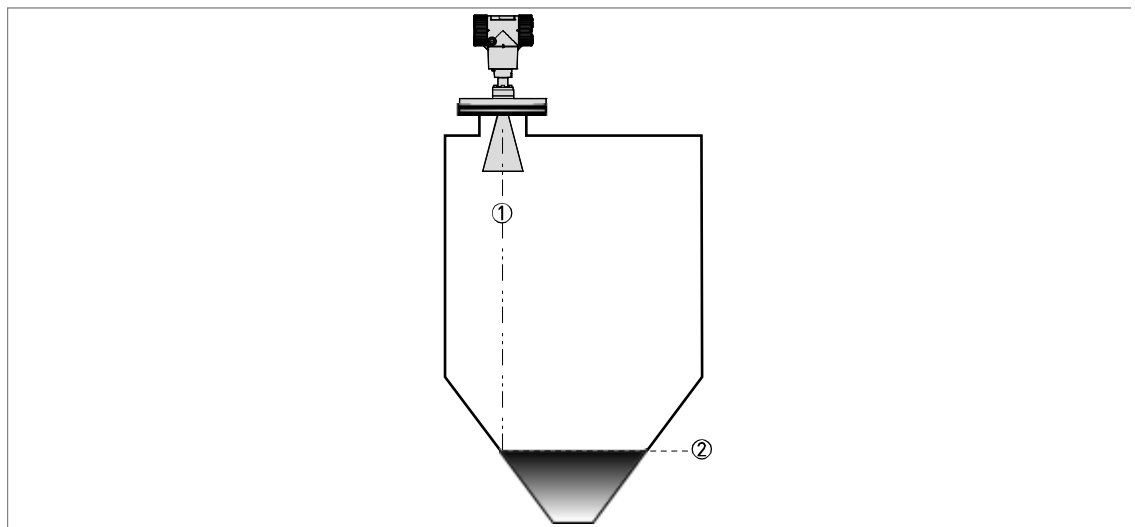

Figure 3-8: Tanks with conical bottoms

Conical bottoms have an effect on the measuring range. The device cannot measure to the bottom of the tank.

- ① Axis of radar beam
- ② Minimum level reading

3.2.3 Mounting restrictions

Follow these recommendations to make sure that the device measures correctly.

We recommend that you prepare the installation when the tank is empty.

Mounting restrictions: General data

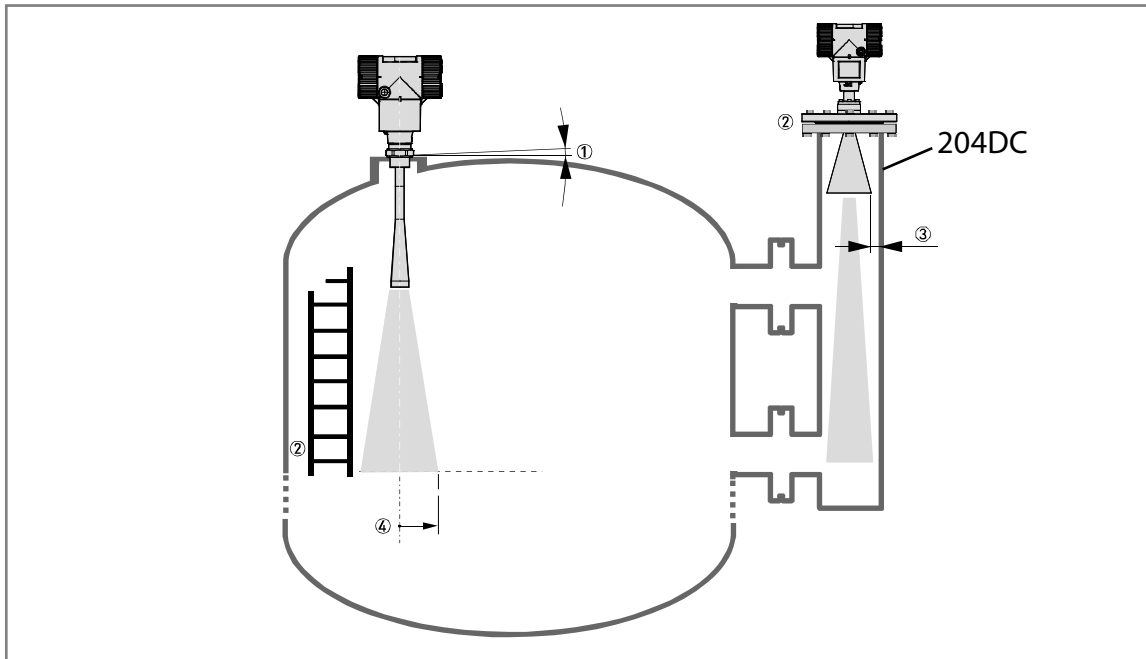

Figure 3-9: Mounting restrictions: General data

- ① Do not tilt the device more than 2°
- ② We recommend that you do an empty spectrum recording if there are too many obstacles in the radar beam (refer to Operation). If necessary, install a bypass chamber 204DC (see PSS 204xx) or stilling well or use an "S" antenna extension or a "L" antenna extension (the device must be installed on the side of the tank) to move the device away from obstacles.
- ③ 5 mm / 0.2" max. for high-dielectric constant liquids
- ④ Beam radius (DN80 (3") Metallic Horn antenna): increments of 290 mm/m or 3.4"/ft (16°)
 Beam radius (DN100 (4") Metallic Horn antenna): increments of 210 mm/m or 2.6"/ft (12°)
 Beam radius (DN150 (6") Metallic Horn antenna): increments of 140 mm/m or 1.7"/ft (8°)
 Beam radius (DN200 (8") Metallic Horn antenna): increments of 100 mm/m or 1.3"/ft (6°)
 Beam radius (PP Wave Horn and PTFE Wave Horn antenna): increments of 176 mm/m or 2.1"/ft (10°)

Obstacles in the tank

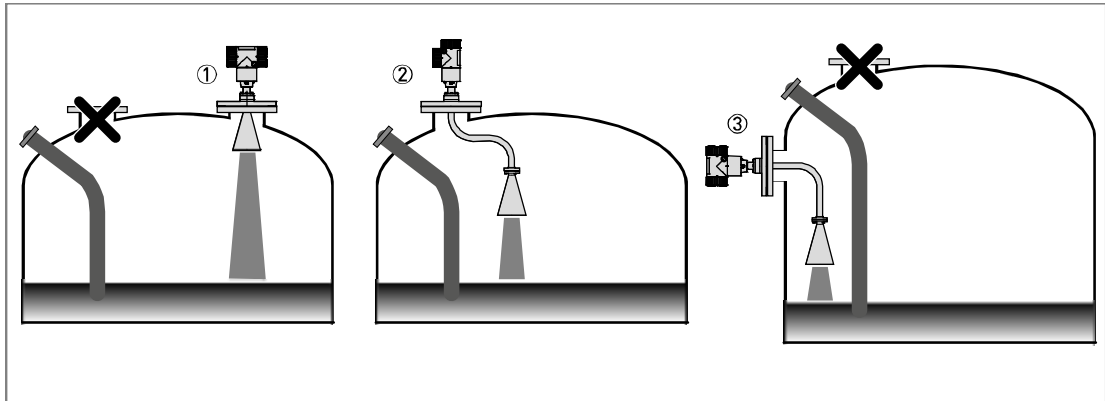

Figure 3-10: Obstacles in the tank

Do not put the device directly above obstacles (agitator, support beams, heating tubes etc.). Interference signals from obstacles will cause the device to measure incorrectly.

- ① Solution 1: Put the device on another process connection away from obstacles
- ② Solution 2: Use the same process connection, but also use an "S" extension
- ③ Solution 3: Attach the device to the side of the tank and use an "L" (right angle) extension

Do not put the device near to the product inlet. If the product that enters the tank touches the antenna, the device will measure incorrectly. If the product fills the tank directly below the antenna, the device will also measure incorrectly.

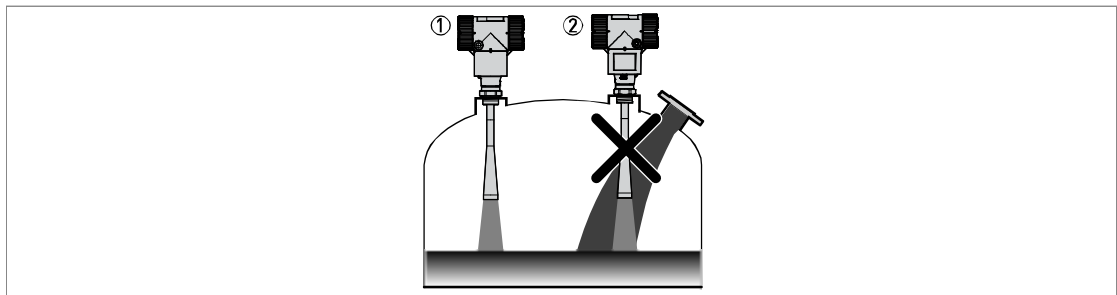

Figure 3-11: Product inlets

- ① The device is in the correct position.
- ② The device is too near to the product inlet.

Devices with Metallic Horn antenna

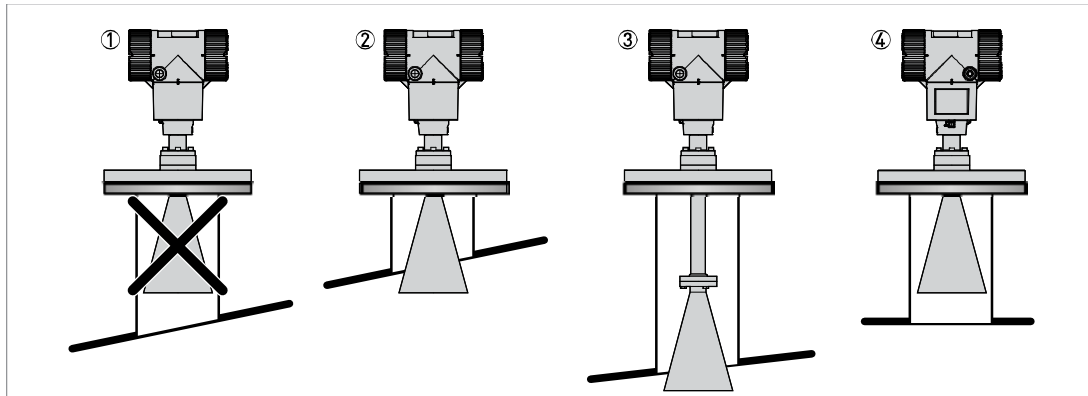

Figure 3-12: Devices with Metallic Horn antenna

- ① If the roof is not flat, the antenna must project out of the nozzle
- ② Short tank nozzle
- ③ Long tank nozzle (device with an antenna extension)
- ④ If the roof is flat and the tank fitting is symmetrical, it is not necessary for the antenna to project out of the nozzle. Thus, the device can have a larger measuring range.

The antenna must project out of the nozzle. If necessary, use an antenna extension. But if the tank roof is flat and the tank fitting is symmetrical, it is not necessary for the antenna to project out of the nozzle. Thus, the device can have a larger measuring range.

Devices with PTFE or PP Wave Horn antenna

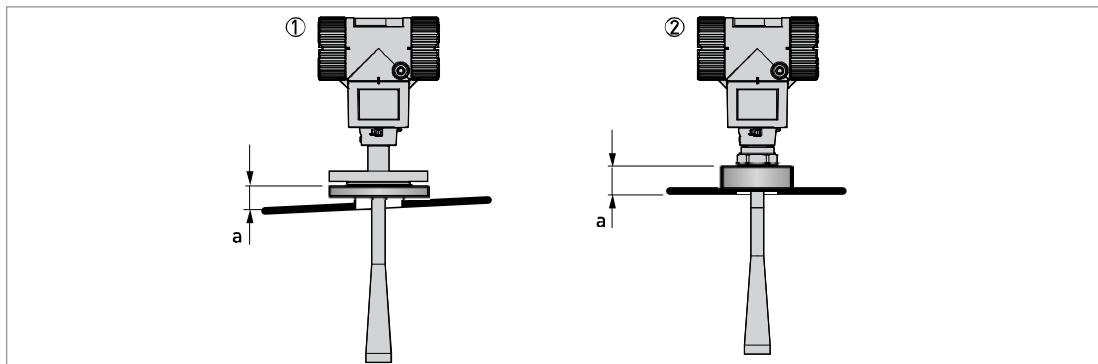

Figure 3-13: Devices with PTFE or PP Wave Horn antenna

Recommended height of tank process connection, $a = 44...200 \text{ mm} / 1.7...7.87''$

- ① Device with a PTFE Wave Horn antenna and a flange connection. There are antenna extension options available (100 mm / 4", 200 mm / 8" and 300 mm / 12") for long nozzles.
- ② Device with a PP Wave Horn antenna and a thread connection

If there are interference signals, the device will not measure correctly. Interference signals are caused by:

- Objects in the tank.
- Sharp corners that are perpendicular to the path of the Radar beam.
- Sudden changes in tank diameter in the path of the Radar beam.

Do an Empty Tank Spectrum recording (refer to Operation) to remove interference signals with a filter.

3.2.4 Standpipes (stilling wells and bypass chambers)

Use a standpipe if:

- There is highly conductive foam in the tank.
- The liquid is very turbulent or agitated.
- There are too many other objects in the tank.
- The device is measuring a liquid (petro-chemicals) in a tank with a floating roof.
- The device is installed in a horizontal cylindrical tank (refer to the end of this section)

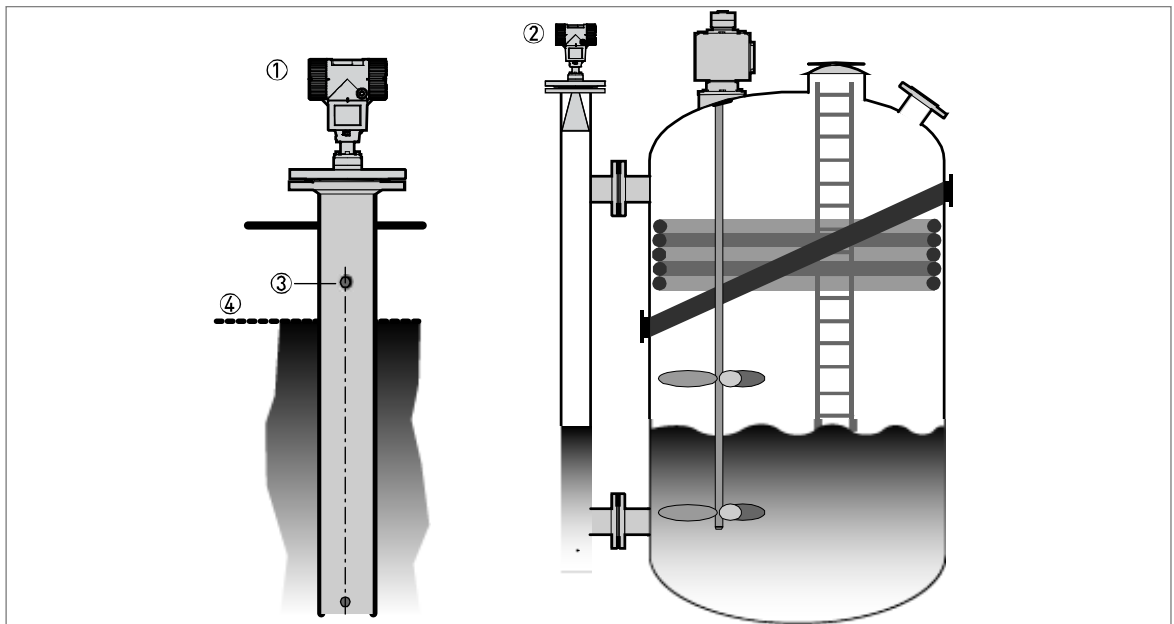

Figure 3-16: Installation recommendations for standpipes (stilling wells and bypass chambers)

- ① A stilling well solution
- ② A bypass chamber solution
- ③ Air circulation hole
- ④ Level of the liquid

Installation requirements

- The standpipe must be electrically conductive.
- The inside diameter of the standpipe must not be more than 5 mm / 0.2" over the diameter of the antenna (for a high-dielectric constant liquid).
- The standpipe must be straight. There must be no sudden changes in internal diameter greater than 1 mm / 0.04".
- The standpipe must be vertical.
- Recommended surface roughness: $<\pm 0.1$ mm / 0.004".
- Make sure that there are no deposits at the bottom of the standpipe.
- Make sure that there is liquid in the standpipe.

Stilling wells - reference point

We recommend that you attach a flat cruciform target at the bottom of the stilling well. It must have a width of $1/3$ of the internal diameter of the stilling well tube. This target is the limit of the measuring range in the stilling well.

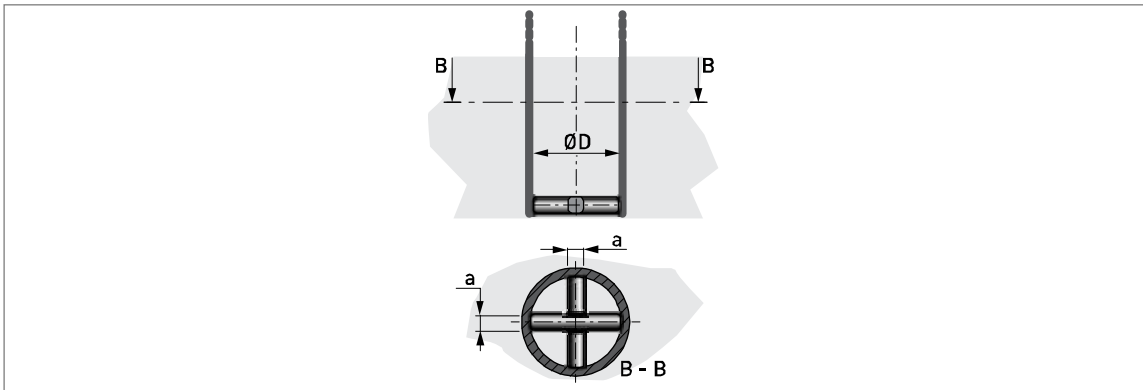

Figure 3-13: Reference point in the stilling well

$$a \geq 1/3 \times \text{ØD}$$

Stilling wells: floating roofs

If the device must be installed on a tank with a floating roof, install it in a stilling well.

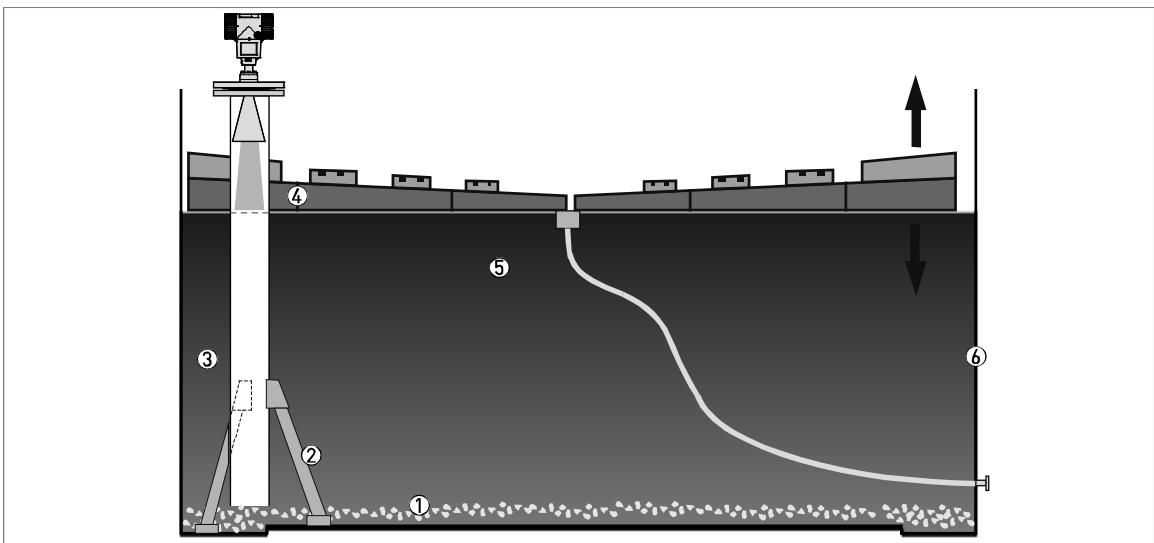

Figure 3-17: Floating roofs

- ① Sediment
- ② Support fixtures
- ③ Stilling well
- ④ Floating roof
- ⑤ Product
- ⑥ Tank

Stilling wells: horizontal cylindrical tanks

We recommend that you install the device in a stilling well if the device:

- is for a horizontal cylindrical tank,
- is in a metallic tank,
- measures a product with a high dielectric constant and
- is on the centerline of the tank.

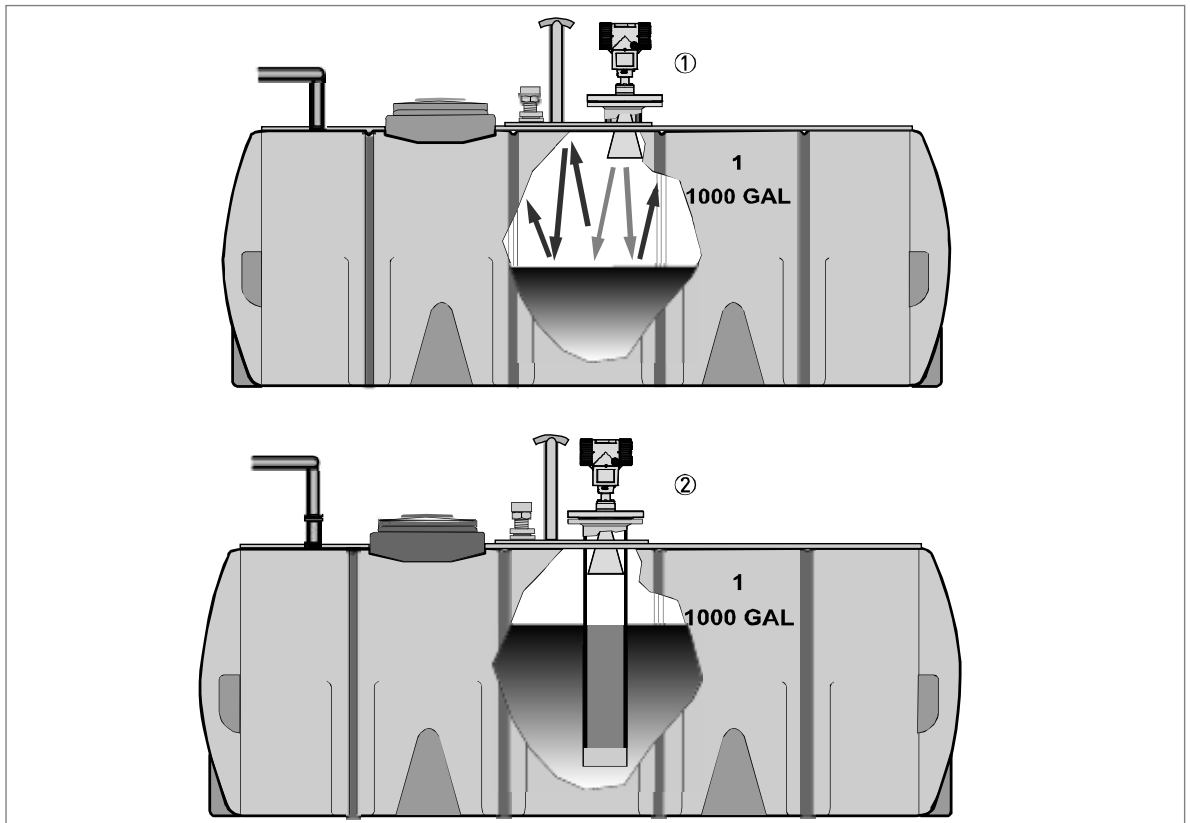

Figure 3-18: Horizontal cylindrical tanks

- ① The device is installed without a stilling well. There are multiple reflections. Refer to the CAUTION! that follows.
- ② The device is installed in a stilling well and measures correctly.

If the device is installed in horizontal cylindrical tank that contains a high dielectric constant liquid without a stilling well, do not put it on the tank centerline. This will cause multiple reflections and the device will not measure accurately. Use the 2.3.12 Multiple Reflections function in Supervisor > Basic Parameters to keep the effects of multiple reflections to a minimum. For more data, refer to "Function description" in the handbook.

Bypass chambers

Installation next to tanks containing one liquid and foam

- The top process connection of the bypass chamber must be above the maximum level of liquid.
- The bottom process connection of the bypass chamber must be below the lowest measured level of liquid.

Installation next to tanks containing more than one liquid

- The top process connection of the bypass chamber must be above the maximum level of liquid.
- The bottom process connection of the bypass chamber must be below the lowest measured level of liquid.
- Additional process connections are necessary for the liquids to circulate freely along the length of the bypass chamber.

4.1 Electrical installation: 2-wire, loop-powered

4.1.1 Compact version

Terminals for electrical installation

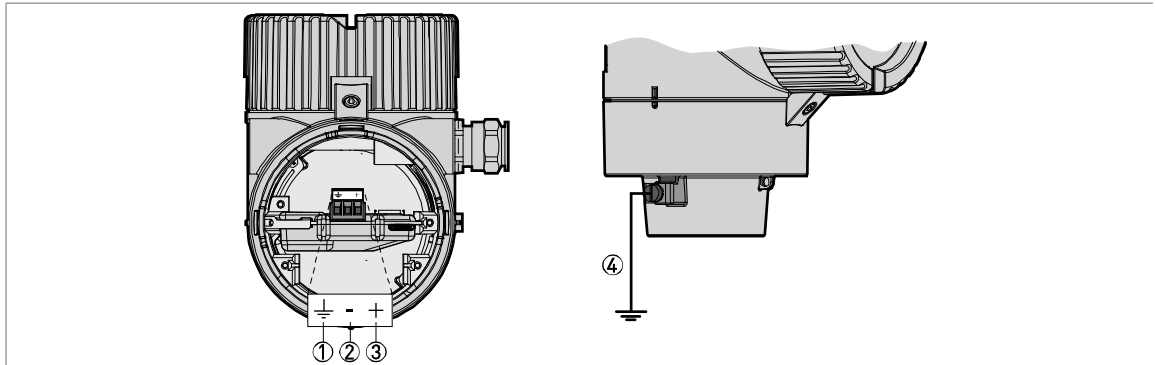

Figure 4-1: Terminals for electrical installation

- ① Grounding terminal in the housing (if the electrical cable is shielded)
- ② Current output -
- ③ Current output +
- ④ Location of the external grounding terminal (at the bottom of the converter)

Electrical power to the output terminal energizes the device. The output terminal is also used for HART® communication.

4.1.2 Remote version

Terminals for electrical installation

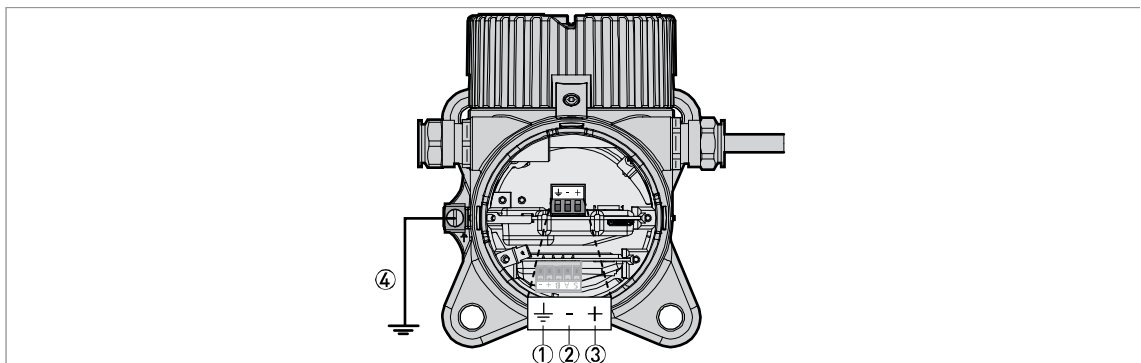

Figure 4-5: Terminals for electrical installation

- ① Grounding terminal in the housing (if the electrical cable is shielded)
- ② Current output -
- ③ Current output +
- ④ Location of the external grounding terminal (on the wall support)

Electrical power to the output terminal energizes the device. The output terminal is also used for HART® communication.

Connections between the remote converter and the antenna housing

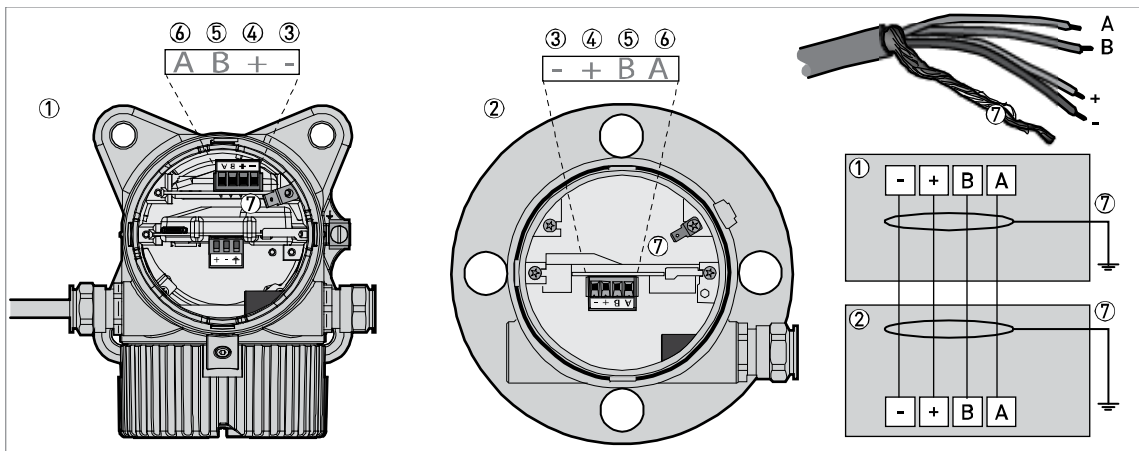

Figure 4-9: Connections between the remote converter and the antenna housing

- ① Remote converter
- ② Antenna housing
- ③ Power supply: voltage in -
- ④ Power supply: voltage in +
- ⑤ Signal cable B
- ⑥ Signal cable A
- ⑦ Shielding wire (attached to Faston connectors in the housings of the remote converter and the antenna housing)

For more electrical installation data, refer to Compact version on page 43.

4.2 Non-Ex devices

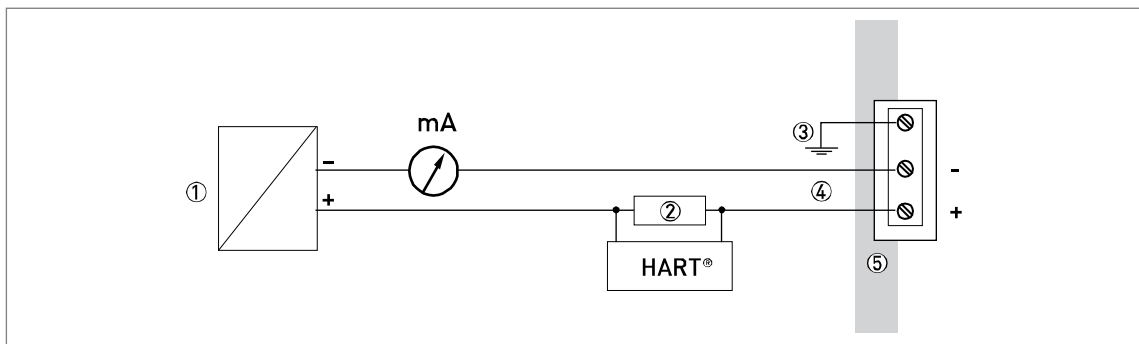

Figure 4-12: Electrical connections for non-Ex devices

- ① Power supply
- ② Resistor for HART® communication
- ③ Optional connection to the grounding terminal
- ④ Output: 12...30 VDC for an output of 22 mA at the terminal
- ⑤ Device

4.3 Devices for hazardous locations

For electrical data for device operation in hazardous locations, refer to the related certificates of compliance and supplementary instructions (ATEX, IECEx, cFMus, ...). You can find this documentation on the DVD-ROM delivered with the device or it can be downloaded free of charge from our website.

4.4 Networks

4.4.1 General information

The device uses the HART[®] communication protocol. This protocol agrees with the HART[®] Communication Foundation standard. The device can be connected point-to-point. It can also operate in a multi-drop network of up to 15 devices.

The device output is factory-set to communicate point-to-point. To change the communication mode from point-to-point to multi-drop, refer to "Network configuration" in the handbook.

4.4.2 Point-to-point connection

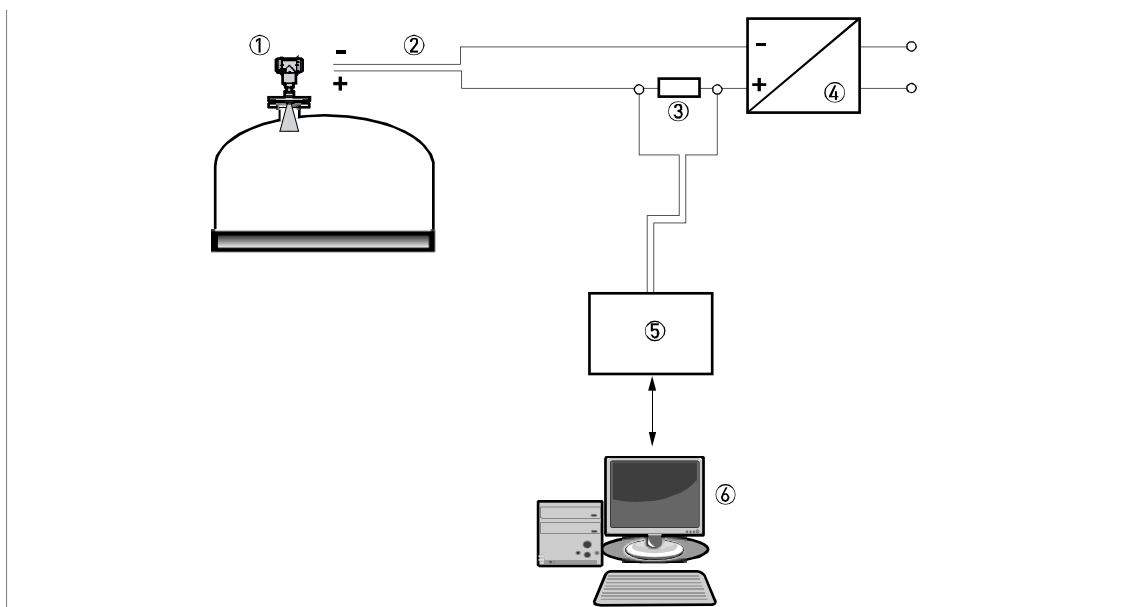

Figure 4-14: Point-to-point connection (non-Ex)

- ① Address of the device (0 for point-to-point connection)
- ② 4...20 mA + HART[®]
- ③ Resistor for HART[®] communication
- ④ Power supply
- ⑤ HART[®] converter
- ⑥ HART[®] communication software

4.4.3 Multi-drop networks

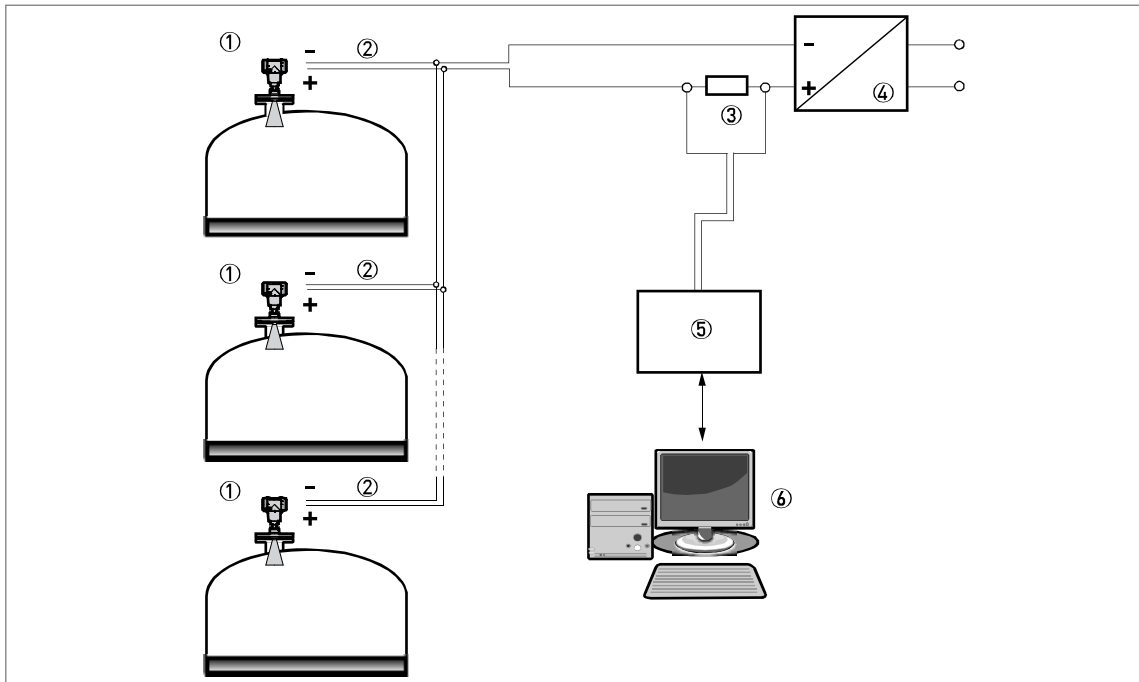

Figure 4-15: Multi-drop network (non-Ex)

- ① Address of the device (each device must have a different address in multidrop networks)
- ② 4 mA + HART®
- ③ Resistor for HART® communication
- ④ Power supply
- ⑤ HART® converter
- ⑥ HART® communication software

5.1 Model code

290114

LR01	4	Two-wire Loop powered Free-Space Radar Level Meter
		Converter / Version (Housing material)
	1	LevelWave LR01: Compact version (Aluminum - IP 66/67)
	2	LevelWave LR01: Compact version (Stainless steel - IP 66/67)
	3	LevelWave LR01: Remote version (Aluminum - IP 66/67)
	4	LevelWave LR01: Remote version (Stainless steel - IP 66/67)
	5	LevelWave LR01: Remote version (MIXED: converter housing: Aluminum - IP 66/67 & antenna housing: Stainless steel - IP 66/67)
		Approval
	0	Without
	1	ATEX Ex ia IIC T2...T6 + DIP ①
	2	ATEX Ex d ia IIC T2..T6 + DIP ①
	4	ATEX Ex ic IIC T2...T6 + DIP (Zone 2 & 22)
	6	IECEX Ex ia IIC T2...T6 + DIP ①
	7	IECEX Ex d ia IIC T2...T6 + DIP ①
	8	IECEX Ex d ic IIC T2...T6 + DIP (Zone 2 & 22)
	A	cFMus IS CL I/II/III, DIV 1, GPS A-G; CL I, Zone 0/20, Ex ia IIC/IIIC T2...T6
	B	cFMus XP-IS/DIP CL I/II/III, DIV 1, GPS A-G (A not for CAN); CL I, Zone 0/20, Ex d/tb IIC/IIIC T2...T6
	C	cFMus NI CL I/II/III, DIV 2, GPS A-G; CL I, Zone 2, Ex nA IIC T2...T6
	L	NEPSI Ex ia IIC T2 ~ T6 + DIP ①
	M	NEPSI Ex d ia IIC T2 ~ T6 + DIP ①
	R	INMETRO Ex ia IIC T2...T6 + DIP
	S	INMETRO Ex d ia IIC T2...T6 + DIP
	T	INMETRO Ex ic IIC T2...T6 + DIP (Zone 2 & 22)
		Other approval
	0	Without
	1	SIL 2 - only available for LevelWave LR01 Compact Version with 4...20 mA output
	4	CRN (Canadian Registration Number)
	5	CRN & SIL 2 - only available for LevelWave LR01 Compact Version with 4...20 mA output
LR01	4	Order code (complete this code on the pages that follow)

					Process seal (material to be checked by customer)
					Material / Temperature / Pressure
				1	FKM/FPM / -40°C...+150°C (-40°F...+302°F) / -1...40 barg (-14.5...580 psig) ②
				5	EPDM / -50°C...+130°C (-58°F...+266°F) / -1...40 barg (-14.5...580 psig)
				6	Kalrez® 6375 / -20°C...+150°C (-4°F...+302°F) / -1...40 barg (-14.5...580 psig)
				A	PFA / -60°C...+130°C (-76°F...+266°F) / -1...40 barg (-14.5...580 psig)
				D	HT FKM/FPM / -40°C...+200°C (-40°F...+392°F) / -1...40 barg (-14.5...580 psig) ②
				K	HT Kalrez® 6375 / -20°C...+250°C (-4°F...+482°F) / -1...40 barg (-14.5...580 psig)
				R	PP Wave Horn / -20°C...+100°C (-4°F...+212°F) / -1...16 barg (-14.5...232 psig)
				T	PTFE Wave Horn / -50°C...+150°C (-58°F...+302°F) / -1...40 barg (-14.5...580 psig)
					Material and Antenna
					Antenna type / Material / Length
				1	Metallic Horn / 316L DN 80 (3in) / L= 110 mm (4.3in)
				2	Metallic Horn / 316L DN 100 (4in) / L= 148 mm (5.8in)
				3	Metallic Horn / 316L DN 150 (6in) / L= 223 mm (8.8in)
				4	Metallic Horn / 316L DN 200 (8in) / L= 335 mm (13.2in)
				G	Wave Horn / PP / L= 322 mm (12.7in)
				H	Wave Horn / PTFE / L= 296 mm (11.6in)
				L	Metallic Wave Guide / 316L / L ≤ 1 m (3.28 ft)
				M	Metallic Wave Guide / 316L / L ≤ 1.5 m (4.92 ft)
				N	Metallic Wave Guide / 316L / L ≤ 2 m (6.56 ft)
				P	Metallic Wave Guide / 316L / L ≤ 2.5 m (8.2 ft)
				R	Metallic Wave Guide / 316L / L ≤ 3 m (9.84 ft)
				S	Metallic Wave Guide / 316L / L ≤ 3.5 m (11.48 ft)
				T	Metallic Wave Guide / 316L / L ≤ 4 m (13.12 ft)
				U	Metallic Wave Guide / 316L / L ≤ 4.5 m (14.76 ft)
				V	Metallic Wave Guide / 316L / L ≤ 5 m (16.4 ft)
				W	Metallic Wave Guide / 316L / L ≤ 5.5 m (18.04 ft)
				X	Metallic Wave Guide / 316L / L ≤ 6 m (19.68 ft)
LR01	4				Order code (complete this code on the pages that follow)

									Antenna extension and Material
									0 Without
									6 100 mm (4in) PTFE, L = 396 mm (15.6in) ③
									7 200 mm (8in) PTFE, L = 496 mm (19.5in) ③
									8 300 mm (12in) PTFE, L = 596 mm (23.5in) ③
									E 100 mm (4in) 316L for the Metallic Horn only
									F 200 mm (8in) 316L for the Metallic Horn only
									G 300 mm (12in) 316L for the Metallic Horn only
									H 400 mm (16in) 316L for the Metallic Horn only
									K 500 mm (20in) 316L for the Metallic Horn only
									R 1000 mm (40in) 316L for the Metallic Horn only
									W S-bend extension 316L
									X L-bend (right angle) extension 316L
									Process Connection: Size (EN 1092-1, ASME B16.5, JIS B2220)
									G Thread
									H DN50 EN 1092-1 ③
									L DN80 EN 1092-1
									M DN100 EN 1092-1
									P DN150 EN 1092-1
									R DN200 EN 1092-1
									H 2in ASME B16.5
									L 3in ASME B16.5
									M 4in ASME B16.5
									P 6in ASME B16.5
									R 8in ASME B16.5
									H 50A JIS B2220
									L 80A JIS B2220
									M 100A JIS B2220
									P 150A JIS B2220
									R 200A JIS B2220
									Process Connection: Pressure Class or Thread
									P G 1½ for the PP Wave Horn only
									A 1½" NPT for the PP Wave Horn only
									E PN 16
									G PN 40
									1 150 lbs
									2 300 lbs
									U JIS 10K
LR01	4								Order code (complete this code on the pages that follow)

																					Active Display language (Modules with 4 languages)			
																					0	Without (if no Display)		
																					1	English (in Language module EN - DE - FR - IT)		
																					2	German (in Language module EN - DE - FR - IT)		
																					3	French (in Language module EN - DE - FR - IT)		
																					4	Italian (in Language module EN - DE - FR - IT)		
																					5	Spanish (in Language module EN - ES - FR - PT)		
																					6	Portuguese (in Language module EN - ES - FR - PT)		
																					7	Japanese (in Language module EN - JA - ZH - RU)		
																					8	Chinese (simplified) (in L. module EN - JA - ZH - RU)		
																					A	Russian (in Language module EN - JA - ZH - RU)		
																						Remote option		
																						0	Without (for compact version)	
																						6	Signal cable 10 m (32.81 ft)	
																						7	Signal cable 25 m (82.02 ft)	
																						8	Signal cable 50 m (164.04 ft)	
																						A	Signal cable 75 m (246.06 ft)	
																						B	Signal cable 100 m (328.08 ft)	
																						0	(this column is always zero)	
																							Calibration certificate	
																							0	Without for standard accuracy ± 10 mm (0.39 in) up to 10 m (32.81 ft)
																							1	Calibration certificate ±5 mm (0.2 in), 2 points
																								TAG Number
																							0	Without
																							1	Tag-No. on stainless steel plate (16 characters max)
																								Extra option
																							0	Without
																							1	NACE-Design (MR 0175 / MR 0103 / ISO 15156) Certificate not included (7)
																							3	Heating / Cooling (Metallic Horn only) (8)
																							5	Purging (Metallic Horn only) (8)
																							6	Purging + Heating / Cooling (Metallic Horn only) (8)
																							A	Purging with gas (Metallic Horn only)
																							B	Purging with gas + Heating/Cooling (Metallic Horn only)
LR01	4																					0	Order code	

- ① DIP= Dust Ignition Proof
- ② DIP= Cl. II/III Div. 1 Gr. E, F, G
- ③ For device dimensions, refer to the "Dimensions and weights" section
- ④ For the PP Wave Horn antenna option only
- ⑤ Other flange faces are available. Refer to your local supplier for more data. Flanges with the PTFE Wave Horn antenna option have a slip on-type design with an anti-blowout feature.
- ⑥ Minimum flange size for the PTFE Wave Horn antenna. This is not available for the Metallic Horn antenna.
- ⑦ This flange is not available for the PTFE Wave Horn antenna option
- ⑧ For DN150 and DN200 Metallic Horn antenna only

Invensys, the Invensys logo, ArchestrA, Avantis, DolpHin, Esscor, Eurotherm, Foxboro Eckardt, Foxboro, I/A Series, Foxboro Evo, IMServ, InFusion, SimSci, Skelta, Triconex, and Wonderware are trademarks of Invensys plc, its subsidiaries or affiliates. All other brands and product names may be the trademarks or service marks of their representative owners.

© 2013 Invensys Systems, Inc. All rights are strictly reserved.

No part of the material protected by this copyright may be reproduced or utilized in any form or by any means, electronic or mechanical, including photocopying, recording, broadcasting, or by any information storage and retrieval system, other than for the purpose to act as an aid in operating the equipment to which the document relates without permission in writing from Invensys Systems, Inc. Invensys pursues a policy of continuous development and product improvement. The specifications, and terms within this document may therefore be changed without notice. The information in this document is given in good faith, but is intended for guidance only. Invensys will accept no responsibility for any losses arising from errors in this document.

FOXBORO ECKARDT GmbH
Pragstr. 82
D-70376 Stuttgart • Germany
Tel. +49 (0)711 502-0
Fax +49 (0)711 502-597



<http://www.foxboro-eckardt.com>

DOKT 558 617 016

invensys[™]