

## LG01 Guided Wave Radar Level Meter



The LevelWave LG01 is designed to perform continuous level measurement in a wide range of industries and applications. Foxboro Eckardt is known for more than 50 years of experience in level measurement as a leading supplier of extremely robust, durable and reliable level measurements. Unaffected by changes in temperature, specific gravity, pressure and with no need to recalibrate, offering a highly available measurement at low maintenance cost. With the LevelWave LG01 you achieve a highly modular system which is designed for the requirements of the modern industry.

### FEATURES

- 2-wire Loop powered TDR technology
- 360° rotatable housing with snap solution
- Housing and cover with bayonet connectors
- Horizontal or vertical housing position
- Remote converter (up to 100 m / 328 ft)
- Weather protection cap
- Measuring range up to 40 m / 130 ft
- Measurements down to 1.1 DK possible
- Quick Noise Scanning (QNS) function
- HART Communication, 4 to 20 mA
- Configuration via FDT-DTM
- Continuous self-diagnostics, Status and diagnostic messages, acc. to NE 107
- Process temperature from -50 to +300 °C
- Process pressure -1 to 40 bar
- SIL2-compliant acc. to IEC 61508 for safety related systems
- Local multilingual full graphic LCD, configurable in %, mA or physical units
- Display with external keypad

## CONTENTS

1 Product features	3
1.1 The modular TDR solution.....	3
1.2 Overview.....	5
1.3 Applications.....	7
1.4 Application table for probe selection.....	8
1.5 Measuring principle .....	9
2 Technical data	10
2.1 Technical data .....	10
2.2 Minimum power supply voltage.....	15
2.3 Pressure / flange temperature table for probe selection.....	16
2.4 Measurement limits .....	17
2.5 Dimensions and weights .....	20
3 Installation	28
3.1 Intended use .....	28
3.2 How to prepare the tank before you install the device .....	28
3.2.1 General information for nozzles.....	28
3.2.2 Installation requirements for concrete roofs .....	30
3.3 Installation recommendations for liquids .....	31
3.3.1 General requirements.....	31
3.3.2 Installation in standpipes (stilling wells and bypass chambers).....	32
3.4 Installation recommendations for solids .....	34
3.4.1 Nozzles on conical silos .....	34
4 Electrical connections	35
4.1 Electrical installation: 2-wire, loop-powered.....	35
4.1.1 Compact version.....	35
4.1.2 Remote version .....	35
4.2 Non-Ex devices .....	36
4.3 Devices for hazardous locations.....	37
4.4 Networks .....	37
4.4.1 General information .....	37
4.4.2 Point-to-point networks.....	37
4.4.3 Multi-drop networks .....	38
5 Order information	39
5.1 Model code.....	39

# 1 PRODUCT FEATURES

## 1.1 The modular TDR solution

This device is a Guided Wave Radar TDR Level Meter for measuring distance, level, volume and mass. Its modular design makes it an economical and reliable solution for most applications.

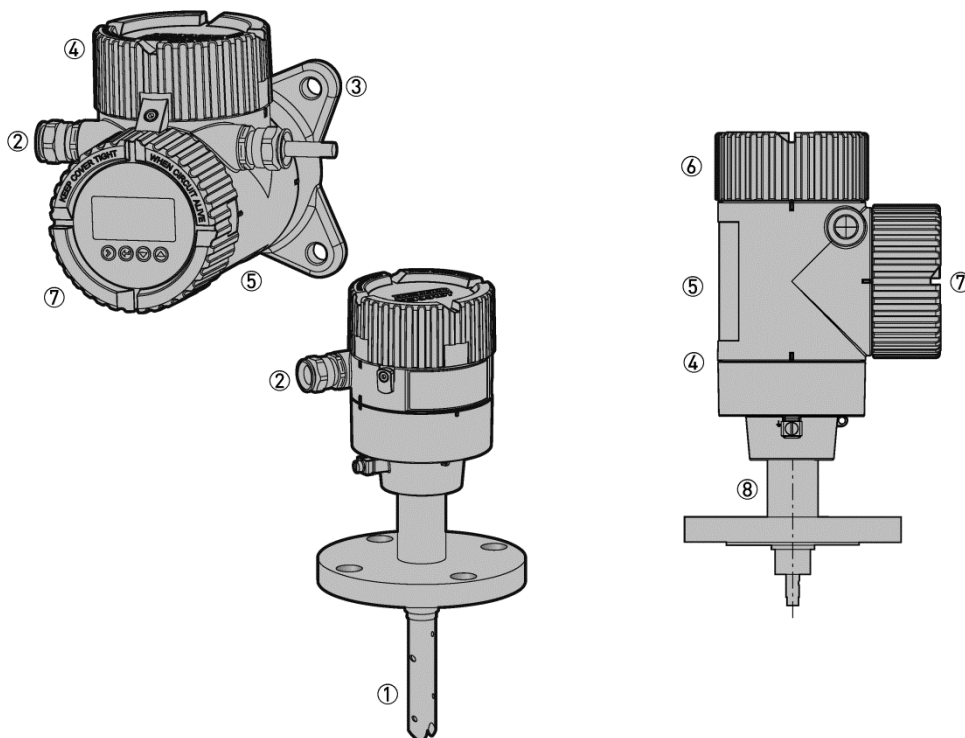

- ① Large choice of probes to cover a large range of applications
- ② Optional remote converter can be installed up to 100 m / 328 ft away from the probe
- ③ Wall support
- ④ Horizontal / vertical housings and segmented probe options makes the device suitable for many applications and for installation in a variety of positions
- ⑤ Aluminum or stainless steel housing
- ⑥ 2-wire level meter
- ⑦ Optional LCD display with external 4-button keypad
- ⑧ Converter is rotatable and removable under process conditions

### Optional integrated display

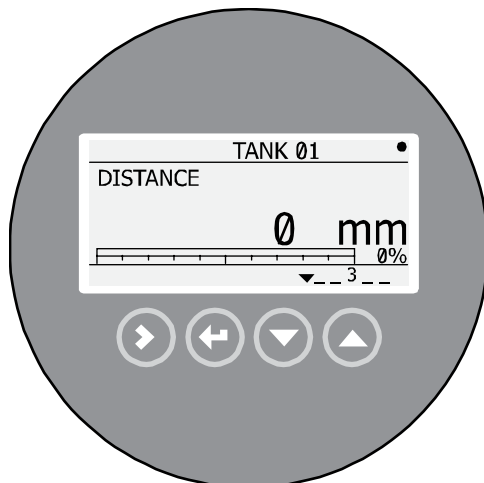

The display can be ordered with the device or as an accessory. It shows measurement data on a 128 × 64 pixel screen. The configuration menu permits the device to be set up in a small number of intuitive steps.

## Highlights

- 2-wire loop-powered HART<sup>®</sup> TDR level meter for liquids and solids
- QNS (Quick Noise Scanning): the software dynamically eliminates false reflections caused environmental disturbances and product build-up
- Horizontal or vertical housing position to suit every installation
- Snap coupling system permits removal of the housing under process conditions and rotation of the housing through 360° for easier reading of display screen
- Bayonet housing cover permits easy opening and closing, even after years in service
- The remote converter can be installed up to 100 m / 328 ft from the probe
- Display keypad is directly accessible without opening the cover
- Measuring range up to 40 m / 130 ft
- SIL2-compliant according to IEC 61508 for safety-related systems - Full FMEDA analysis available

## Industries

- Chemical market
- Oil & Gas
- Power
- Food
- Wastewater
- Pulp & Paper
- Metals, Minerals & Mining

## Applications

- Liquid level measurement in process tanks for various chemical products
- Liquid volume measurement for storage tanks

## 1.2 Overview

### Level Wave LG01 - Compact / Vertical version

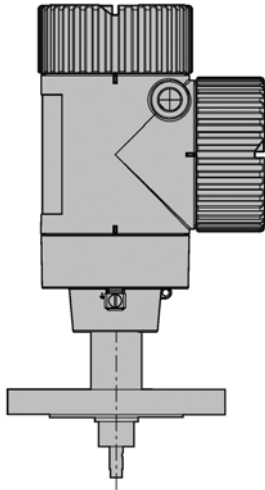

- The converter is vertical in relation to the process connection. It is also attached to the process connection (compact version).
- For installation of the device on the ground or in a recess.
- The optional LCD display is attached to the top of the device.

### Level Wave LG01 - Compact / Horizontal version

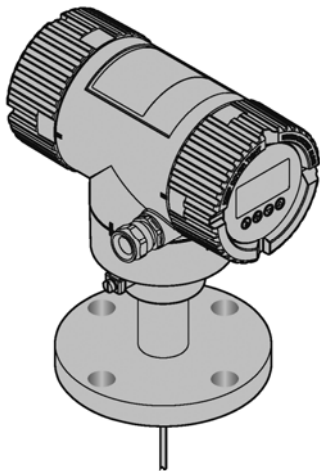

- The converter is horizontal in relation to the process connection. It is also attached to the process connection (compact version).
- This version is ideal for installation in areas with low roof clearances.
- For locations where it is easier to read data on the optional LCD display if the converter is in a horizontal position.

## Level Wave LG01 - Remote version



- Users can read measurements and configure the device from the bottom of the tank.
- The remote converter can be installed up to 100 m / 328 ft away from the process connection on the tank. No external power supply needed.
- Attach the remote converter to a wall, pipe or rigid surface with the supplied wall support.

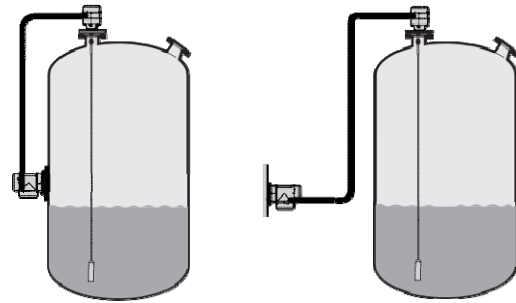

## Weather protection

A weather protection option can also be ordered with the device. It is recommended for outdoor applications.



- Must be ordered with the device.
- Can be ordered for both, compact versions of the device and the probe housing of the remote version.
- Easily opened and closed.

### 1.3 Applications

#### 1. Level measurement of liquids

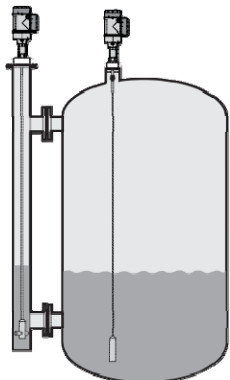

The level meter can measure the level of a wide range of liquid products on a large variety of installations within the stated pressure and temperature range. It does not require any calibration: it is only necessary to adapt the probe length and do a short configuration procedure.

#### 2. Level measurement of solids

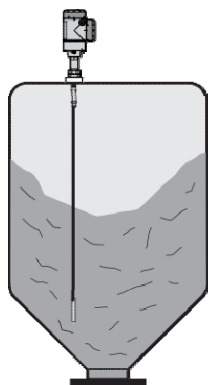

The level meter has a Ø4 mm / 0.15" single cable probe for measuring powders and granulates in silos up to 20 m / 65.6 ft high. It does not require any calibration: it is only necessary to adapt the probe length and do a short configuration procedure.

#### 3. Volume measurement

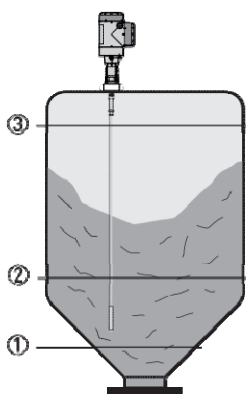

A strapping table function is available in the configuration menu for volume measurement. Up to 30 volume values can be related to level values. For example:

- Level ① = 2 m / Volume ① = e.g. 0.7 m<sup>3</sup>
- Level ② = 10 m / Volume ② = e.g. 5 m<sup>3</sup>
- Level ③ = 20 m / Volume ③ = e.g. 17 m<sup>3</sup>

This data permits the device to calculate volumes between strapping table entries.

### 1.4 Application table for probe selection

	Double rod	Single rod	Single rod (segmented)	Coaxial	Coaxial (segmented)	Double cable	Single cable Ø4 mm / 0.15"	Single cable Ø2 mm / 0.08"
--	------------	------------	------------------------	---------	---------------------	--------------	----------------------------	----------------------------

#### Maximum probe length, L

4 m / 13 ft	■	■						
6 m / 20 ft			■	■	■			
40 m / 130 ft						■	■	■

#### Liquids

Liquid application	■	■	■	■	■	■	■	■
LPG, LNG	■	①	①	■	■	■	①	①
Highly viscous liquids		■	■				■	■
Highly crystallizing liquids		■	■				■	■
Highly corrosive liquids		②	③	■	■		■	■
Foam		■	■	■	■		■	■
Agitated liquids	④	④	④	④	④	④	④	④
Spray in tank		①	①	■	■		①	①
Storage tanks		■	■	■	■	■	■	■
Installation in bypass chamber		■	■	■	■	■	■	■
Small diameter nozzles and long nozzles	■	④	④	■	■		④	④
Stilling wells	■	■	■	■	■	■	■	■

#### Solids

Powders		■					⑤	
Granules, <5 mm / 0.2"		■					⑤	

■ standard    □ on request

- ① Install the device in a stilling well or a bypass chamber
- ② Make a selection from one of these 2 options: a probe made of Hastelloy® C-22 or a probe with a PVC, PVDF or PP protective sheath
- ③ Use a probe made of Hastelloy® C-22
- ④ Use this probe with an anchor fitting. For more data, refer to the handbook.
- ⑤ Max. length is 20 m / 65.5 ft; more on request



## 1.5 Measuring principle

This Guided Wave Radar Level Meter has been developed from a proven technology called Time Domain Reflectometry (TDR).

The device transmits low-intensity electromagnetic pulses of approximately one nanosecond width along a rigid or flexible conductor. These pulses move at the speed of light. When the pulses reach the surface of the product to be measured, the pulses are reflected back to the signal converter.

The device measures the time from when the pulse is transmitted to when it is received: half of this time is equivalent to the distance from the reference point of the device to the surface of the product. The time value is converted into an output current of 4...20 mA.

Dust, foam, vapor, agitated surfaces, boiling surfaces, changes in pressure, changes in temperature, changes in dielectric constant and changes in density do not have an effect on device performance.

### TDR measurement of level

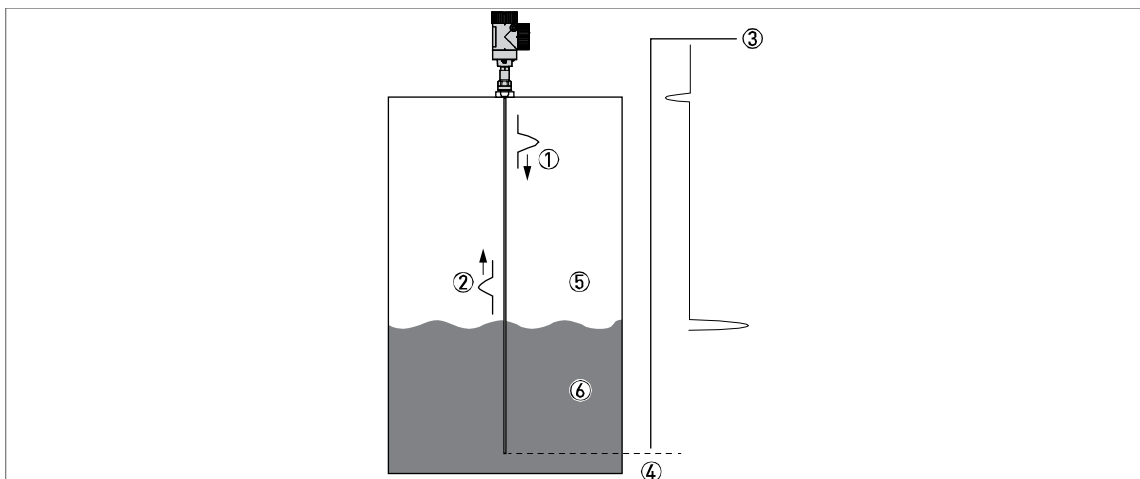

Figure 1-1: TDR measurement of level

- ① Transmitted pulses
- ② Reflected pulse
- ③ Pulse amplitude
- ④ Time of flight
- ⑤ Air,  $\epsilon_r = 1$
- ⑥  $\epsilon_r \geq 1.4$  in direct mode or  $\epsilon_r \geq 1.1$  in TBF mode

## 2 TECHNICAL DATA

### 2.1 Technical data

- The following data is provided for general applications. If you require data that is more relevant to your specific application, please contact us or your local representative.
- Additional information (certificates, special tools, software,...) and complete product documentation can be downloaded free of charge from our website.

#### Converter

#### Measuring system

Application	Level and volume measurement of liquids, pastes, powders and granulates
Measuring principle	TDR (time domain reflectometry)
Construction	Measuring probe attached directly to a signal converter

#### Operating conditions

Ambient temperature	-40...+80°C / -40...+176°F Integrated LCD display: -20...+60°C / -5...+140°F; if the ambient temperature is not in these limits, the display switches off
Storage temperature	-50...+85°C / -60...+185°F (min. -40°C / -40°F for devices with the integrated LCD display option)
Protection category	IP 66/67 equivalent to NEMA type 4X (housing) and type 6P (probe)

#### Materials

Housing	Polyester-coated aluminum or stainless steel (1.4404 / 316L)
Cable entry	Plastic (non-Ex devices: black, intrinsically-safe devices: blue); nickel-plated brass (explosion proof devices only), stainless steel (explosion proof devices only)

#### Electrical connections

Power supply (terminals)	Terminals output - Non-Ex / Ex i: 12...30 VDC; min./max. value for an output of 22 mA at the terminal
	Terminals output - Ex d: 16...36 VDC; min./max. value for an output of 22 mA at the terminal
Current output load	Non-Ex / Ex i: $R_L [\Omega] \leq ((U_{ext}-12 V)/22 \text{ mA})$ . For more data, refer to Minimum power supply voltage on page 15.
	Ex d: $R_L [\Omega] \leq ((U_{ext}-16 V)/22 \text{ mA})$ . For more data, refer to Minimum power supply voltage on page 15.
Cable entry	M20×1.5; ½" NPT
Cable gland	Standard: none
	Options: M20×1.5 (cable diameter: 6...12 mm / 0.23...0.47"); others are available on request
Communication cable - remote version	None for non-Ex devices (4-wire shielded cable of max. length 100 m / 328 ft to be supplied by the customer). Supplied with all Ex-approved devices.
Cable entry capacity (terminal)	0.5...1.5 mm <sup>2</sup>

#### Input and output

Measured variable	Time between the emitted and received signal
Output signal	4...20 mA HART® or 3.8...20.5 mA acc. to NAMUR NE 43 ①
Resolution	±1 µA
Error signal options	High: 22 mA; Low: 3.6 mA acc. to NAMUR NE 43; Hold (frozen value - not available if the output agrees with NAMUR NE 43) ②

## Display and user interface

User interface options	LCD display (128 × 64 pixels in 8-step grayscale with 4-button keypad)
Languages	9 languages are available: English, German, French, Italian, Spanish, Portuguese, Japanese, Chinese (Mandarin) and Russian

## Approvals and certification

CE	This device fulfils the statutory requirements of the EC directives. The manufacturer certifies successful testing of the product by applying the CE mark.
Vibration resistance	EN 60721-3-4 (1...9 Hz: 3 mm / 10...200 Hz: 1g; 10g shock ½ sinus: 11 ms)
Explosion protection	
ATEX DEKRA 11ATEX0166 X	II 1/2 G, 2 G Ex ia IIC T6...T3 (or T2) Ga/Gb or Ex ia IIC T6...T3 (or T2) Gb;
	II 1/2 D, 2 D Ex ia IIIC T90°C Da/Db or Ex ia IIIC T90°C Db IP6X;
	II 1/2 G, 2 G Ex d ia IIC T6...T3 (or T2) Ga/Gb or Ex d ia IIC T6...T3 (or T2) Gb;
	II 1/2 D, 2 D Ex ia tb IIIC T90°C Da/Db or Ex ia tb IIC T90°C Db IP6X
IECEX IECEX DEK 11.0060 X	Ex ia IIC T6...T3 (or T2) Ga/Gb or Ex ia IIC T6...T3 (or T2) Gb;
	Ex ia IIIC T90°C Da/Db or Ex ia IIIC T90°C Db IP6X;
	Ex d ia IIC T6...T3 (or T2) or Ex d ia IIC T6...T3 (or T2) Gb;
	Ex ia tb IIIC T90°C Da/Db or Ex ia tb IIIC T90°C IP6X
cFMus - Dual Seal-approved	NEC 500
	XP-IS / Cl. I / Div. 1 / Gr. ABCD / T6;
	DIP / Cl. II/III / Div. 1 / Gr. EFG / T6;
	IS / Cl. I/II/III / Div. 1 / Gr. ABCDEFG / T6;
	NI / Cl. I / Div. 2 / Gr. ABCD / T6
	NEC 505
	Cl. I / Zone 0 / AEx d [ja] / IIC / T6;
	Cl. I / Zone 0 / AEx ia / IIC / T6;
	Cl. I / Zone 2 / AEx nA [ja] / IIC / T6;
	Hazardous (Classified) Locations, indoor/outdoor Type 4X and 6P, IP66, Dual Seal
	CEC Section 18 (Zone ratings)
	Cl. I, Zone 1, Ex d, IIC (Probe: Zone 0), T6;
	Cl. I, Zone 0, Ex ia, IIC, T6;
	Cl. I, Zone 2, Ex nA, IIC, T6 DIP A21 IP66 TB 95°C
	CEC Section 18 and Annex J (Division ratings)
Cl. I, Div. 1/2, Gr. ABCD; Cl. II, Gr. EFG; Cl. III, T6;	
NEPSI	Ex ia IIC T2/T3~T6 DIP A21 T <sub>A</sub> IP66;
	Ex dia IIC T2/T3~T6 DIP A21 T <sub>A</sub> IP66

Other standards and approvals	
SIL	Compact version only: SIL 2 - certified according to all the requirements in EN 61508 (Full Assessment) and for high/low demand mode operation. HFT=0, SFF=94.3% (for non-Ex / Ex i devices) or 92.1% (for Ex d devices), type B device
EMC	EMC Directives 2004/108/EC in conjunction with EN 61326-1 (2006). The device agrees with this standard if the time constant $\geq 3$ seconds and: - the device has a coaxial probe or - the device has a single / double probe that is installed in a metallic tank. For more data. SIL 2-approved devices agree with EN 61326-3-1 (2006) and EN 61326-3-2 (2006)
NAMUR	NAMUR NE 21 Electromagnetic Compatibility (EMC) of Industrial Process and Laboratory Control Equipment
	NAMUR NE 43 Standardization of the Signal Level for the Failure Information of Digital Transmitters
	NAMUR NE 107 Self-Monitoring and Diagnosis of Field Devices
CRN	This certification is for all Canadian provinces and territories. For more data, refer to the website.
Construction code	On request: NACE MR0175 / ISO 15156; NACE MR0103

① HART® is a registered trademark of the HART Communication Foundation

② Only the 3.6 mA error signal is applicable to SIL-approved devices

## Probe options

	Single cable Ø2 mm / 0.08"	Single cable Ø4 mm / 0.16"	Single rod Ø8 mm / 0.31"
--	-------------------------------	-------------------------------	-----------------------------

## Measuring system

Application	Liquids	Liquids and solids	
Measuring range	1...40 m / 3.3...131 ft	Liquids: 1...40 m / 3.3...131 ft Solids: 1...20 m / 3.3...65.6 ft	1...6 m / 3.3...19.7 ft
Dead zone	This depends on the type of probe. For more data, refer to Measurement limits on page 17.		

## Measuring accuracy

Accuracy (in direct mode)	Standard: ±10 mm / ±0.4", when distance ≤ 10 m / 33 ft; ±0.1% of measured distance, when distance > 10 m / 33 ft  Optional: ±3 mm / ±0.1", when distance ≤ 10 m / 33 ft; ±0.03% of measured distance, when distance > 10 m / 33 ft
Accuracy (in TBF mode)	±20 mm / ±0.8"
Resolution	1 mm / 0.04"
Repeatability	±1 mm / ±0.04"
Maximum rate of change at 4 mA	10 m/min / 32.8 ft/min

## Operating conditions

Max. temperature at the process connection (also depends on the temperature limits of the gasket material. Refer to "Materials" in this table.)	-50...+300°C / -58...+572°F	-50...+150°C / -58...+302°F
Pressure	-1...40 barg / -14.5...580 psig	
Viscosity (liquids only)	10000 mPa.s / 10000 cP	
Dielectric constant	≥ 1.8 in direct mode; ≥ 1.1 in TBF mode	

## Materials

Probe	Stainless steel (1.4404 / 316L)	Stainless steel (1.4401 / 316); Hastelloy® C-22 (2.4602)
Gasket (process seal)	FKM/FPM (-40...+300°C / -40...+572°F); Kalrez® 6375 (-20...+300°C / -4...+572°F); EPDM (-50...+250°C / -58...+482°F) ①	FKM/FPM (-40...+150°C / -40...+302°F); Kalrez® 6375 (-20...+150°C / -4...+302°F); EPDM (-50...+150°C / -58...+302°F) ①
Process connection	Stainless steel (1.4404 / 316L); Hastelloy® C-22 (2.4602)	

## Process connections

Thread	For more data on options, refer to Order code on page 39
Flange	For more data on options, refer to Order code on page 39

① Kalrez® is a registered trademark of DuPont Performance Elastomers L.L.C.

	Double cable 2 × Ø4 mm / 0.16"	Double rod 2 × Ø8 mm / 0.31"	Coaxial Ø22 mm / 0.9"
--	-----------------------------------	---------------------------------	--------------------------

### Measuring system

Application	Liquids		
Measuring range	1...40 m / 3.3...131 ft	1...4 m / 3.3...13.1 ft	1...6 m / 3.3...19.7 ft
Dead zone	This depends on the type of probe. For more data, refer to Measurement limits on page 17.		

### Measuring accuracy

Accuracy (in direct mode)	Standard: ±10 mm / ±0.4", when distance ≤ 10 m / 33 ft; ±0.1% of measured distance, when distance > 10 m / 33 ft
	Optional: ±3 mm / ±0.1", when distance ≤ 10 m / 33 ft; ±0.03% of measured distance, when distance > 10 m / 33 ft
Accuracy (in TBF mode)	±20 mm / ±0.8"
Resolution	1 mm / 0.04"
Repeatability	±1 mm / ±0.04"
Maximum rate of change at 4 mA	10 m/min / 32.8 ft/min

### Operating conditions

Max. temperature at the process connection (also depends on the temperature limits of the gasket material. Refer to "Materials" in this table.)	-50...+150°C / -58...+302°F		
Pressure	-1...40 barg / -14.5...580 psig		
Viscosity (liquids only)	10000 mPa.s / 10000 cP	1500 mPa.s / 1500 cP	500 mPa.s / 500 cP
Dielectric constant	≥ 1.6 in direct mode		≥ 1.4 in direct mode
	≥ 1.1 in TBF mode		

### Materials

Probe	Stainless steel (1.4404 / 316L)	Stainless steel (1.4401 / 316); Hastelloy® C-22 (2.4602)
Gasket (process seal)	FKM/FPM (-40...+150°C / -40...+302°F); Kalrez® 6375 (-20...+150°C / -4...+302°F); EPDM (-50...+150°C / -58...+302°F) ①	
Process connection	Stainless steel (1.4404 / 316L); Hastelloy® C-22 (2.4602)	

### Process connections

Thread	For more data on options, refer to Order code on page 39
Flange	For more data on options, refer to Order code on page 39

① Kalrez® is a registered trademark of DuPont Performance Elastomers L.L.C.

## 2.2 Minimum power supply voltage

Use these graphs to find the minimum power supply voltage for a given current output load.

### Non-Ex and Hazardous Location approved (Ex i / IS) devices

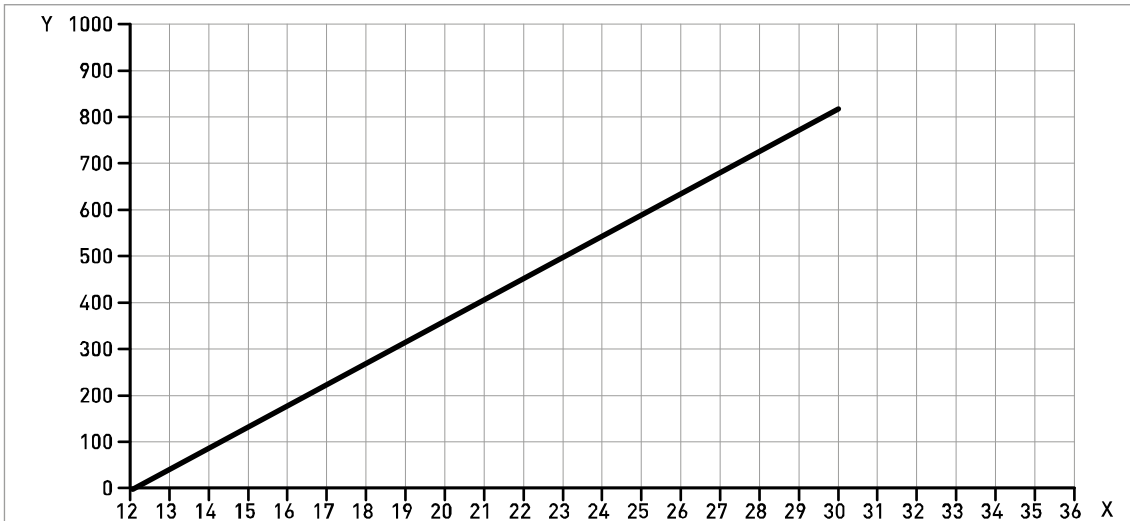

Figure 2-1: Minimum power supply voltage for an output of 22 mA at the terminal (Non-Ex and Hazardous Location approval (Ex i / IS))

X: Power supply U [VDC]  
Y: Current output load  $R_L$  [ $\Omega$ ]

### Hazardous Location (Ex d / XP/DIP/NI) approved devices

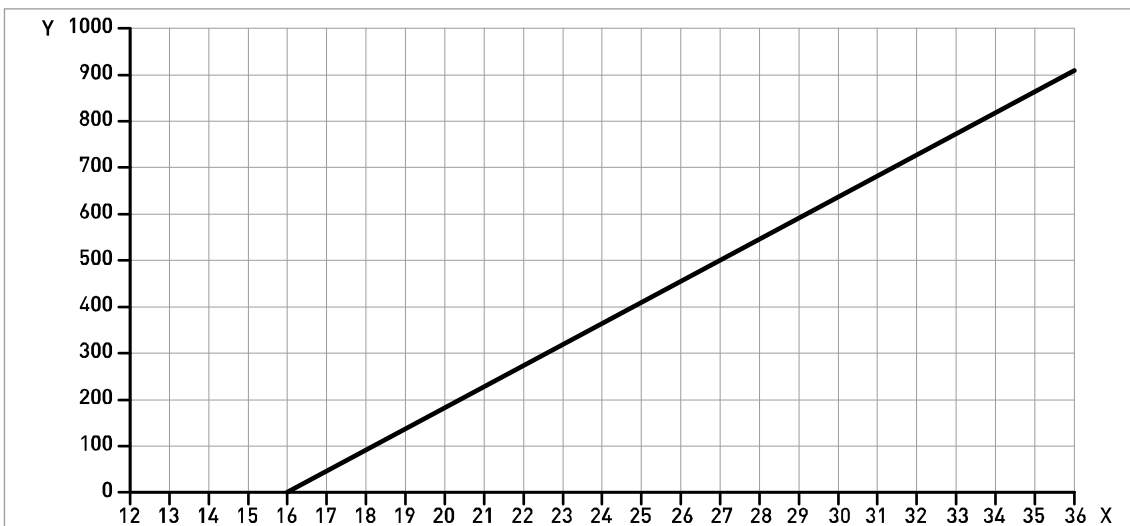

Figure 2-2: Minimum power supply voltage for an output of 22 mA at the terminal (Hazardous Location approval (Ex d / XP/DIP/NI))

X: Power supply U [VDC]  
Y: Current output load  $R_L$  [ $\Omega$ ]

### 2.3 Pressure / flange temperature table for probe selection

Make sure that the transmitters are used within their operating limits. Obey the temperature limits of the process seal and the flange.

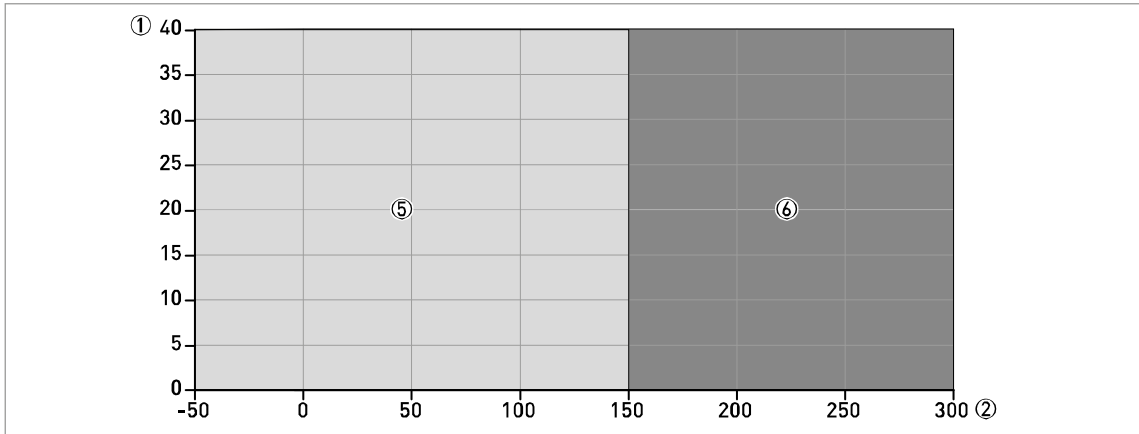

Figure 2-3: Pressure/temperature table for probe selection in °C and barg

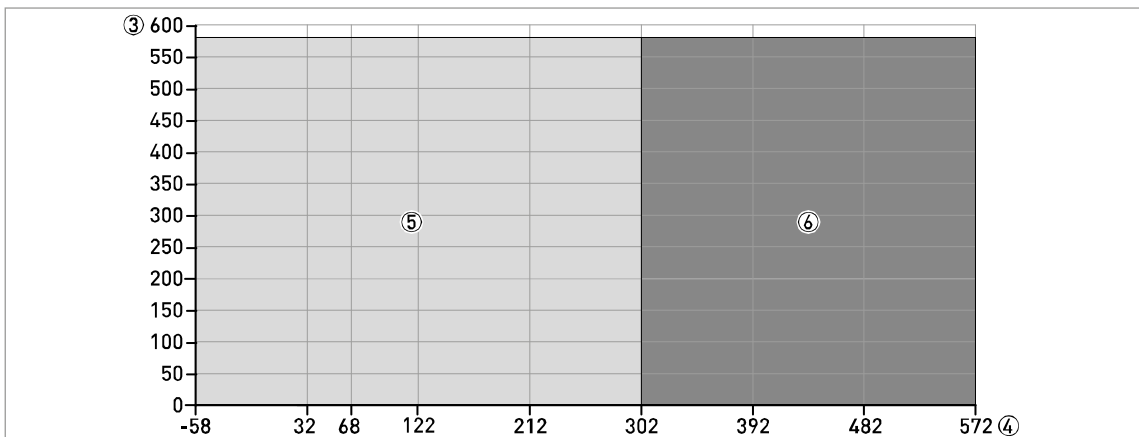

Figure 2-4: Pressure/temperature table for probe selection in °F and psig

- ① Process pressure, Ps [barg]
- ② Process connection temperature, T [°C]
- ③ Process pressure, Ps [psig]
- ④ Process connection temperature, T [°F]
- ⑤ All probes
- ⑥ High-Temperature (HT) version of the Ø2 mm / 0.08" single cable probe

The minimum and maximum process connection temperature and the minimum and maximum process pressure also depends on the gasket material selected. Refer to "Technical data" on page 10.



## 2.4 Measurement limits

### Double cable and double rod probes

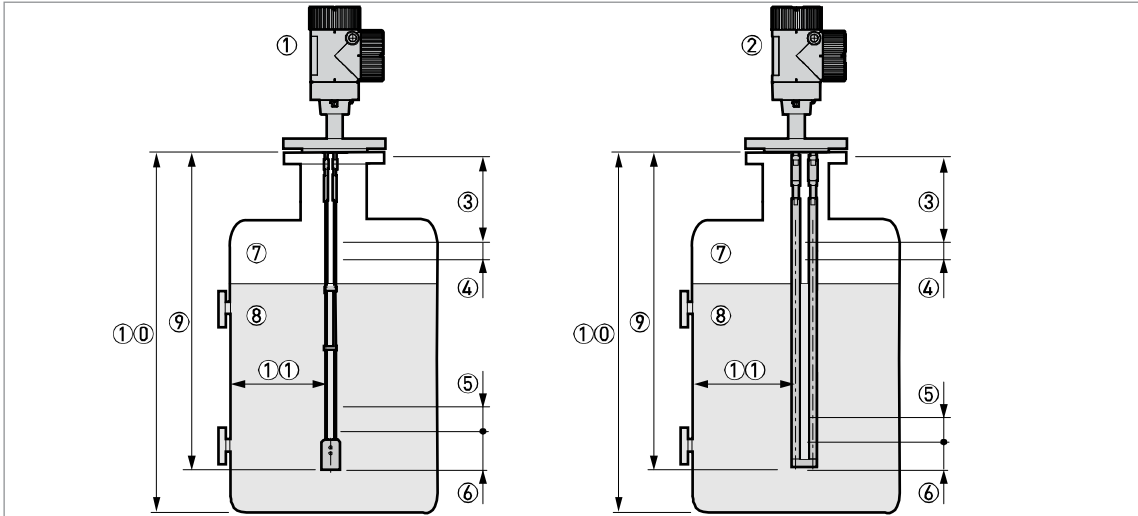

Figure 2-5: Measurement limits

- ① Device with a double cable probe
- ② Device with a double rod probe
- ③ **Top dead zone:** Top part of the probe where measurement is not possible
- ④ **Top non-linearity zone:** Top part of the probe with a lower accuracy of  $\pm 30 \text{ mm} / \pm 1.18''$
- ⑤ **Bottom non-linearity zone:** Bottom part of the probe with a lower accuracy of  $\pm 30 \text{ mm} / \pm 1.18''$
- ⑥ **Bottom dead zone:** Bottom part of the probe where measurement is not possible
- ⑦ **Gas (Air)**
- ⑧ **Product**
- ⑨ **L, Probe length**
- ⑩ **Tank Height**
- ⑪ **Minimum distance from the probe to a metallic tank wall:** Double cable or double rod probes =  $100 \text{ mm} / 4''$

### Measurement limits (dead zone) in mm and inches

Dead zone	$\epsilon_r = 80$				$\epsilon_r = 2.3$			
	Top ③		Bottom ⑥		Top ③		Bottom ⑥	
	[mm]	[inches]	[mm]	[inches]	[mm]	[inches]	[mm]	[inches]
Double cable	200	7.87	80	3.15	300	11.81	80	3.15
Double rod	150	5.91	10	0.39	300	11.81	110	4.33

### Measurement limits (non-linearity zone) in mm and inches

Non-linearity zone	$\epsilon_r = 80$				$\epsilon_r = 2.3$			
	Top ④		Bottom ⑤		Top ④		Bottom ⑤	
	[mm]	[inches]	[mm]	[inches]	[mm]	[inches]	[mm]	[inches]
Double cable	50	1.97	20	0.79	0	0	70	2.76
Double rod	120	4.72	30	1.18	0	0	70	2.76

80 is  $\epsilon_r$  of water; 2.3 is  $\epsilon_r$  of oil

Single cable and single rod probes

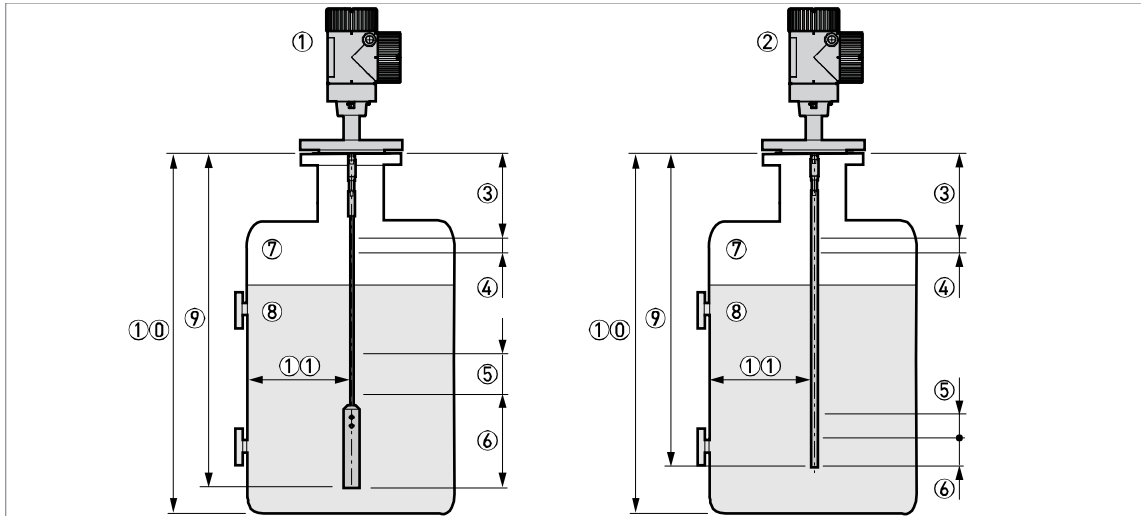

Figure 2-6: Measurement limits

- ① Device with a single cable probe
- ② Device with a single rod probe
- ③ **Top dead zone:** Top part of the probe where measurement is not possible
- ④ **Top non-linearity zone:** Top part of the probe with a lower accuracy of  $\pm 30 \text{ mm} / \pm 1.18''$
- ⑤ **Bottom non-linearity zone:** Bottom part of the probe with a lower accuracy of  $\pm 30 \text{ mm} / \pm 1.18''$
- ⑥ **Bottom dead zone:** Bottom part of the probe where measurement is not possible
- ⑦ **Gas (Air)**
- ⑧ **Product**
- ⑨ **L, Probe length**
- ⑩ **Tank Height**
- ⑪ **Minimum distance from the probe to a metallic tank wall:** Single cable or single rod probes =  $300 \text{ mm} / 12''$

Measurement limits (dead zone) in mm and inches

Dead zone	$\epsilon_r = 80$				$\epsilon_r = 2.3$			
	Top ③		Bottom ⑥		Top ③		Bottom ⑥	
	[mm]	[inches]	[mm]	[inches]	[mm]	[inches]	[mm]	[inches]
Ø2 mm single cable	250	9.84	200	7.87	350	13.78	250	9.84
Ø4 mm single cable	250	9.84	200	7.87	300	11.81	200	7.87
Single rod	150	5.91	50	1.97	300	11.81	170	6.69

Measurement limits (non-linearity zone) in mm and inches

Non-linearity zone	$\epsilon_r = 80$				$\epsilon_r = 2.3$			
	Top ④		Bottom ⑤		Top ④		Bottom ⑤	
	[mm]	[inches]	[mm]	[inches]	[mm]	[inches]	[mm]	[inches]
Ø2 mm single cable	50	1.97	0	0	0	0	50	1.97
Ø4 mm single cable	50	1.97	0	0	0	0	60	2.36
Single rod	150	5.91	0	0	0	0	0	0

80 is  $\epsilon_r$  of water; 2.3 is  $\epsilon_r$  of oil

Coaxial probe

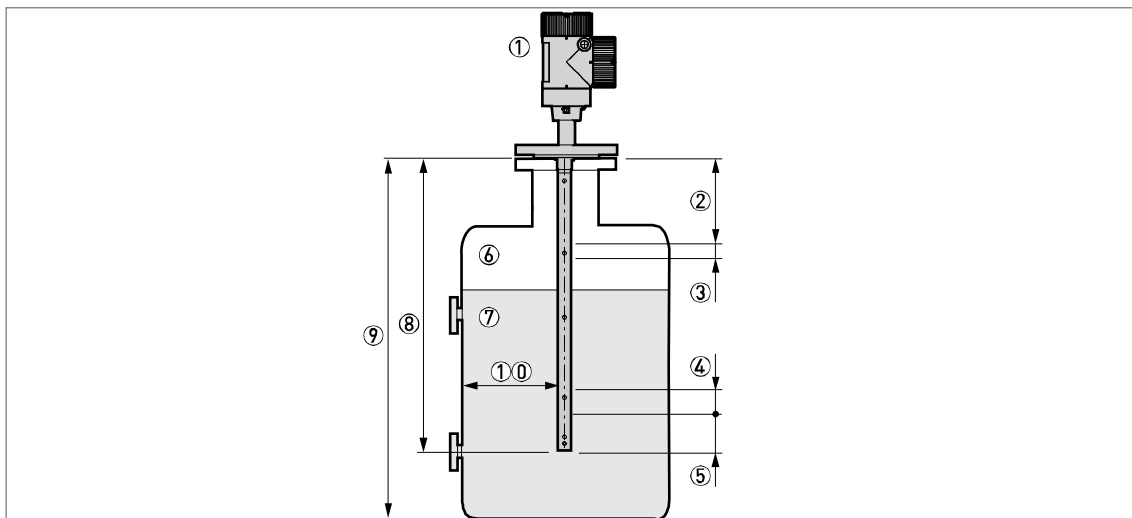

Figure 2-7: Measurement limits

- ① Device with a coaxial probe
- ② **Top dead zone:** Top part of the probe where measurement is not possible
- ③ **Top non-linearity zone:** Top part of the probe with a lower accuracy of  $\pm 30 \text{ mm} / \pm 1.18''$
- ④ **Bottom non-linearity zone:** Bottom part of the probe with a lower accuracy of  $\pm 30 \text{ mm} / \pm 1.18''$
- ⑤ **Bottom dead zone:** Bottom part of the probe where measurement is not possible
- ⑥ **Gas (Air)**
- ⑦ **Product**
- ⑧ **L, Probe length**
- ⑨ **Tank Height**
- ⑩ **Minimum distance from the probe to a metallic tank wall:** Coaxial probe =  $0 \text{ mm} / 0''$

Measurement limits (dead zone) in mm and inches

Dead zone	$\epsilon_r = 80$				$\epsilon_r = 2.3$			
	Top ②		Bottom ⑤		Top ②		Bottom ⑤	
	[mm]	[inches]	[mm]	[inches]	[mm]	[inches]	[mm]	[inches]
Coaxial	150	5.91	0	0	200	7.87	20	0.79

Measurement limits (non-linearity zone) in mm and inches

Non-linearity zone	$\epsilon_r = 80$				$\epsilon_r = 2.3$			
	Top ③		Bottom ④		Top ③		Bottom ④	
	[mm]	[inches]	[mm]	[inches]	[mm]	[inches]	[mm]	[inches]
Coaxial	0	0	50	1.97	0	0	150	5.91

80 is  $\epsilon_r$  of water; 2.3 is  $\epsilon_r$  of oil

## 2.5 Dimensions and weights

### Housing dimensions

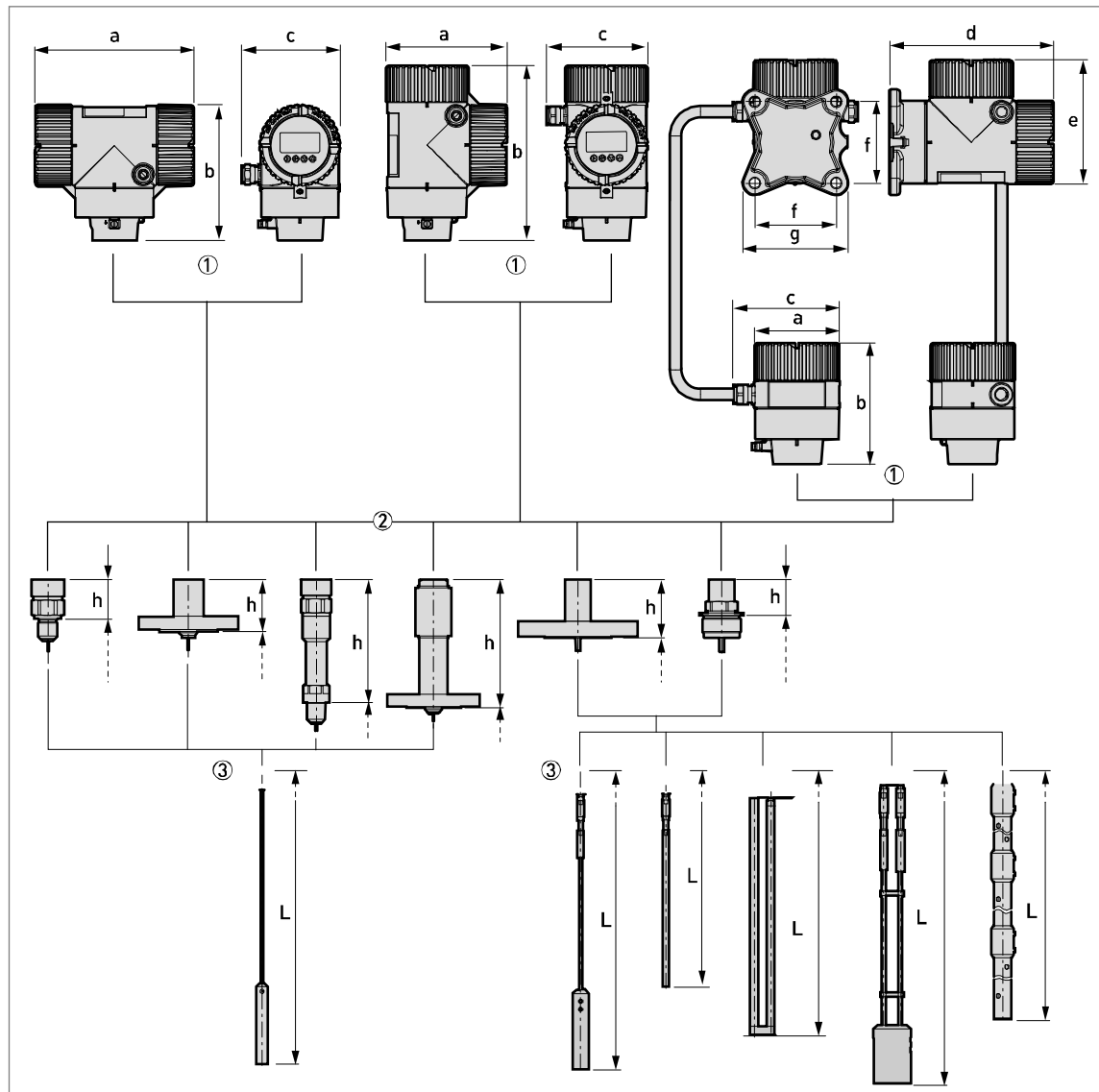

Figure 2-8: Housing dimensions

- ① Housing options. From left to right: compact converter with horizontal housing, compact converter with vertical housing, and remote converter (top) and probe housing (bottom)
- ② Process connection options. From left to right: threaded connection for  $\varnothing 2$  mm / 0.08" single cable probe, flange connection for  $\varnothing 2$  mm / 0.08" single cable probe, high-temperature (HT) threaded connection for  $\varnothing 2$  mm / 0.08" single cable probe, HT flange connection for  $\varnothing 2$  mm / 0.08" single cable probe, threaded connection for other probes, flange connection for other probes
- ③ Probe options. From left to right:  $\varnothing 2$  mm / 0.08" single cable probe,  $\varnothing 4$  mm / 0.16" single cable probe, single rod (single-piece or segmented) probe, double rod probe,  $\varnothing 4$  mm / 0.16" double cable probe and coaxial (single-piece or segmented) probe

All housing covers have bayonet connectors unless it is an explosion-proof (XP / Ex d-approved) device. The terminal compartment cover for explosion-proof devices have a thread with a flame path.

## Housing options: Dimensions in mm

Dimensions [mm]	Compact - horizontal		Compact - vertical		Remote	
	Non-Ex / Exi / IS	Ex d / XP	Non-Ex / Exi / IS	Ex d / XP	Non-Ex / Exi / IS	Ex d / XP
a	191	258	147	210	104	104
b	123	123	209	209	142	142
c	127	127	127	127	129	129
d	-	-	-	-	184	184
e	-	-	-	-	163	226
f	-	-	-	-	100	100
g	-	-	-	-	155	155

## Housing options: Dimensions in inches

Dimensions [inches]	Compact - horizontal		Compact - vertical		Remote	
	Non-Ex / Exi / IS	Ex d / XP	Non-Ex / Exi / IS	Ex d / XP	Non-Ex / Exi / IS	Ex d / XP
a	7.5	10.2	5.79	8.27	4.09	4.09
b	4.84	4.84	8.23	8.23	5.59	5.59
c	5.00	5.00	5.00	5.00	5.08	5.08
d	-	-	-	-	7.24	7.24
e	-	-	-	-	6.42	8.90
f	-	-	-	-	3.94	3.94
g	-	-	-	-	6.10	6.10

## Process connection and probe options: Dimensions in mm

Dimensions [mm]	Probes with threaded connections			Probes with flange connections		
	Ø2 mm single cable probe	HT Ø2 mm single cable probe	Other probes	Ø2 mm single cable probe	HT Ø2 mm single cable probe	Other probes
h	43	169	45	61	186	73
L	For more data, refer to "Single probes" and "Double and coaxial probes" in this section.					

## Process connection and probe options: Dimensions in inches

Dimensions [inches]	Probes with threaded connections			Probes with flange connections		
	Ø0.08" single cable probe	HT Ø0.08" single cable probe	Other probes	Ø0.08" single cable probe	HT Ø0.08" single cable probe	Other probes
h	1.69	6.65	1.77	2.40	7.32	2.87
L	For more data, refer to "Single probes" and "Double and coaxial probes" in this section.					

Weather protection option

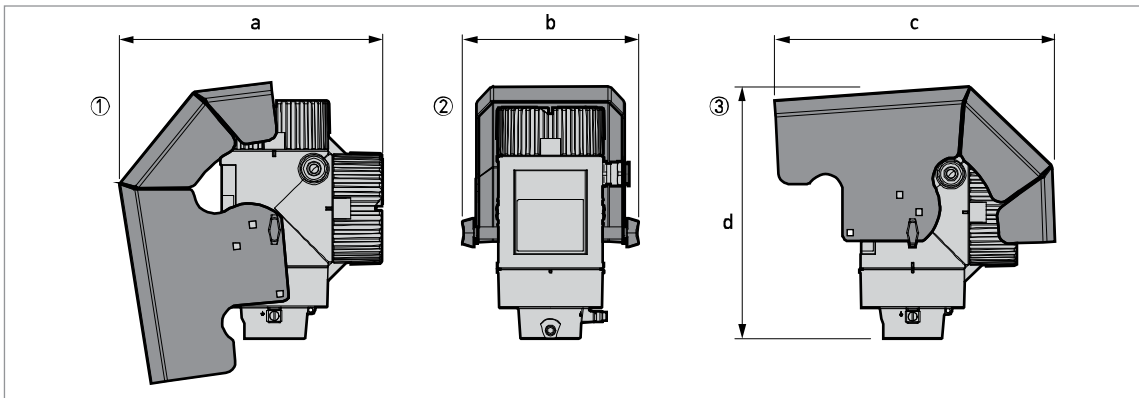

Figure 2-9: Weather protection option for Compact / Vertical and Remote versions

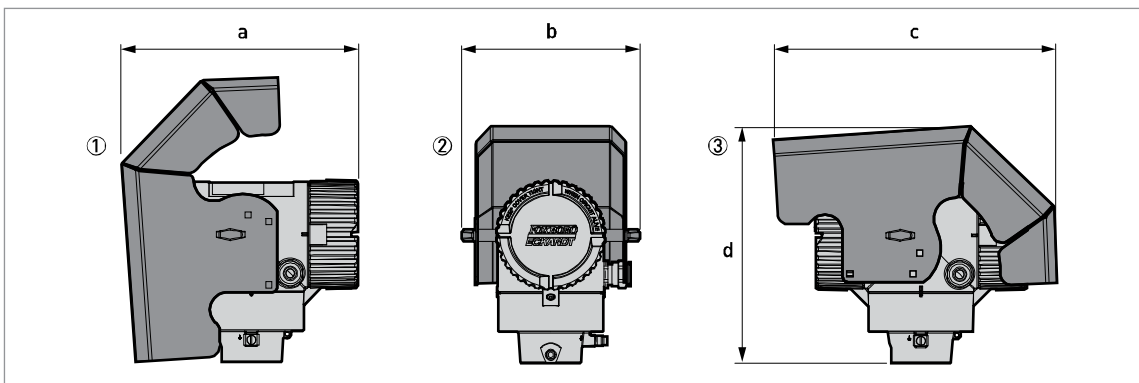

Figure 2-10: Weather protection option for Compact / Horizontal and Remote versions

- ① Left side (with weather protection open)
- ② Rear view (with weather protection closed)
- ③ Right side (with weather protection closed)

Dimensions and weights in mm and kg

	Dimensions [mm]				Weights [kg]
	a	b	c	d	
Weather protection Compact / Vertical or Remote versions	244	170	274	245	1.6
Weather protection Compact / Horizontal or Remote versions	221	170	274	229	1.6

Dimensions and weights in inches and lb

	Dimensions [inches]				Weights [lb]
	a	b	c	d	
Weather protection Compact / Vertical or Remote versions	9.6	6.7	10.8	9.6	3.5
Weather protection Compact / Horizontal or Remote versions	8.7	6.7	10.8	9.0	3.5

Single probes

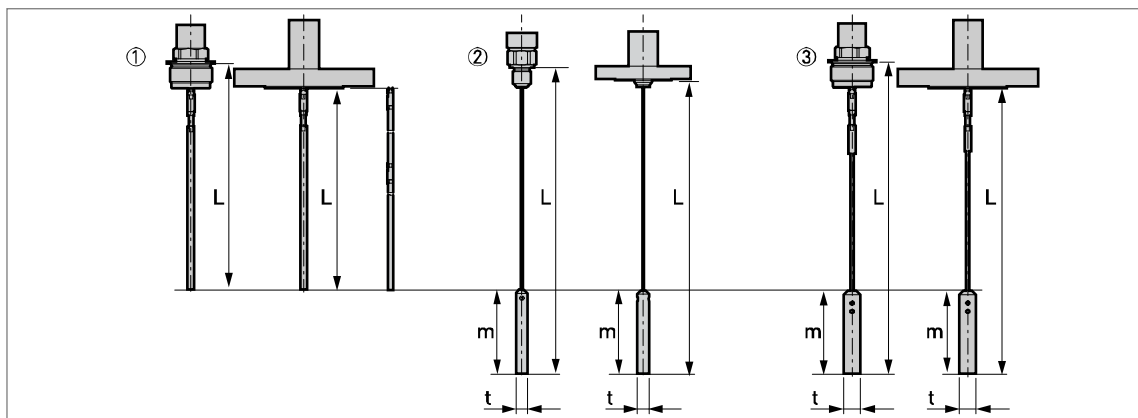

Figure 2-11: Single probe options

- ① Single rod  $\varnothing 8$  mm /  $\varnothing 0.31$ " (thread and flange versions - segmented probe option shown on the right side)
- ② Single cable  $\varnothing 2$  mm /  $\varnothing 0.08$ " (thread and flange versions)
- ③ Single cable  $\varnothing 4$  mm /  $\varnothing 0.16$ " (thread and flange versions)

A wide range of counterweights and anchoring solutions are available. For dimensional data, refer to the pages that follow. For installation data, refer to the handbook.

Single probes: Dimensions in mm

Probes	Dimensions [mm]			
	L min.	L max.	m	t
Single rod $\varnothing 8$ mm ①	1000 ②	4000	-	-
Single rod $\varnothing 8$ mm (segmented) ①	1000 ②	6000	-	-
Single cable $\varnothing 2$ mm ③	1000 ②	40000	100	$\varnothing 14$
Single cable $\varnothing 4$ mm ④	1000 ②	40000	100	$\varnothing 20$

- ① A device with this probe option must be assembled on site. For the assembly procedure, refer to the handbook or the printed procedure supplied with the components.
- ② A shorter probe length is available on request
- ③ 1 counterweight option ( $\varnothing 14 \times 100$  mm)
- ④ Refer to the end of this section for data about all the probe end options

Single probes: Dimensions in inches

Probes	Dimensions [inches]			
	L min.	L max.	m	t
Single rod $\varnothing 0.31$ " ①	39 ②	158	-	-
Single rod $\varnothing 0.31$ " (segmented) ①	39 ②	236	-	-
Single cable $\varnothing 0.08$ " ③	39 ②	1575	3.9	0.6
Single cable $\varnothing 0.16$ " ④	39 ②	1575	4.0	0.8

- ① A device with this probe option must be assembled on site. For the assembly procedure, refer to the handbook or the printed procedure supplied with the components.
- ② A shorter probe length is available on request
- ③ 1 counterweight option ( $\varnothing 0.6 \times 3.9$ " )
- ④ Refer to the end of this section for data about all the probe end options

Double and coaxial probes

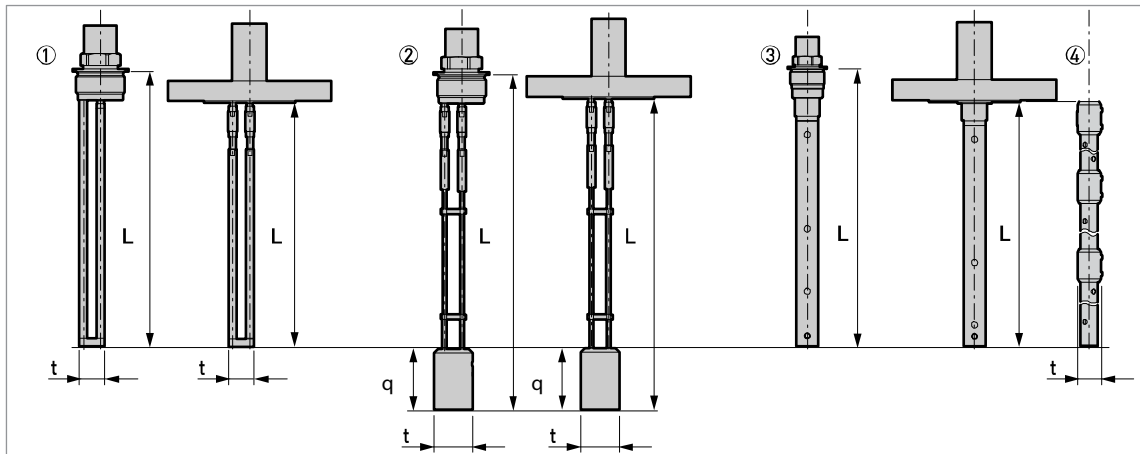

Figure 2-12: Double and coaxial probe options

- ① Double rod Ø8 mm / Ø0.31" (thread and flange versions)
- ② Double cable Ø4 mm / Ø0.16" (thread and flange versions)
- ③ Coaxial Ø22 mm / Ø0.9" (thread and flange versions)
- ④ Coaxial Ø22 mm / Ø0.9" (segmented version)

A wide range of counterweights and anchoring solutions are available. For dimensional data, refer to the pages that follow. For installation data, refer to the handbook.

Double probes: Dimensions in mm

Probes	Dimensions [mm]			
	L min.	L max.	q	t
Double rod Ø8 mm	1000 ①	4000	-	25
Double cable Ø4 mm ②	1000 ①	40000	60	Ø38
Coaxial Ø22 mm	600 ①	6000	-	-
Coaxial Ø22 mm (segmented) ③	600 ①	6000	-	Ø28

- ① A shorter probe length is available on request
- ② Refer to the end of this section for data about all the probe end options
- ③ A device with this probe option must be assembled on site. For the assembly procedure, refer to the handbook or the printed procedure supplied with the components.

Double probes: Dimensions in inches

Probes	Dimensions [inches]			
	L min.	L max.	q	t
Double rod Ø0.31"	39 ①	158	-	1.0
Double cable Ø0.16" ②	39 ①	1575	2.4	Ø1.5
Coaxial Ø0.9"	24 ①	236	-	-
Coaxial Ø0.9" (segmented) ③	24 ①	236	-	Ø1.1

- ① A shorter probe length is available on request
- ② Refer to the end of this section for data about all the probe end options
- ③ A device with this probe option must be assembled on site. For the assembly procedure, refer to the handbook or the printed procedure supplied with the components.



Probe end options for cable probes: single cable Ø4 mm/0.15"

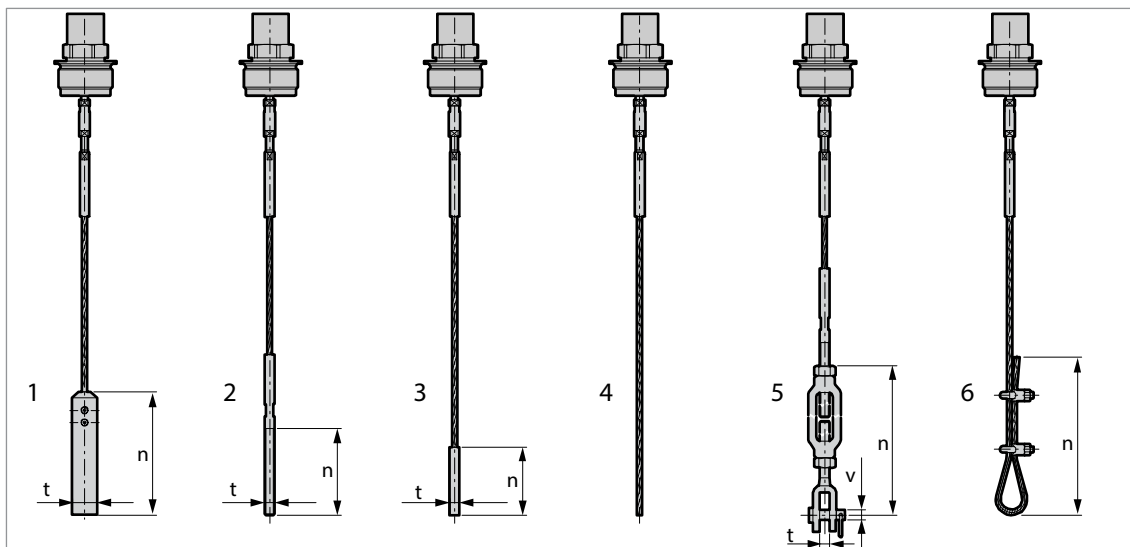

Figure 2-13: Probe end options for cable probes: single cable Ø4 mm/0.15"

- ① Standard counterweight
- ② Threaded end
- ③ Crimped end
- ④ Open end
- ⑤ Turnbuckle
- ⑥ Chuck

Dimensions in mm

Probe end type	Dimensions [mm]		
	n	t	v
Counterweight	100	Ø20	-
Threaded end	70	M8	-
Crimped end	55	Ø8	-
Open end	-	-	-
Turnbuckle	172 ①	11	Ø6
Chuck	300	-	-

① Minimum length

Dimensions in inches

Probe end type	Dimensions [inches]		
	n	t	v
Counterweight	3.9	Ø0.8	-
Threaded end	2.8	M8	-
Crimped end	2.2	Ø0.3	-
Open end	-	-	-
Turnbuckle	6.8 ①	0.4	Ø0.2
Chuck	11.8	-	-

① Minimum length

Probe end options for cable probes: double cable Ø4 mm/0.15"

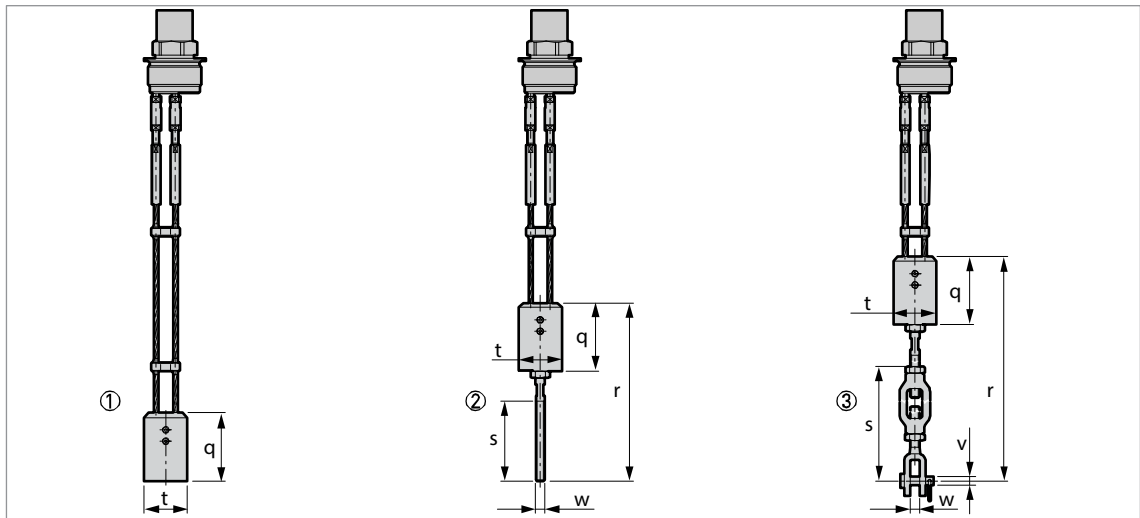

Figure 2-14: Probe end options for cable probes: double cable Ø4 mm/0.15"

- ① Standard counterweight
- ② Threaded end
- ③ Turnbuckle

Dimensions in mm

Probe end type	Dimensions [mm]					
	q	r	s	t	v	w
Counterweight	60	-	-	Ø38	-	-
Threaded end	60	157	70	Ø38	-	M8
Turnbuckle	60	289 ±46	172 ①	Ø38	Ø6	11

① Minimum length

Dimensions in inches

Probe end type	Dimensions [inches]					
	q	r	s	t	v	w
Counterweight	2.4	-	-	Ø1.5	-	-
Threaded end	2.4	6.2	2.8	Ø1.5	-	M8
Turnbuckle	2.4	11.4 ±1.8	6.8 ①	Ø1.5	Ø0.2	0.4

① Minimum length

## Converter and probe housing weights

Type of housing	Weights			
	Aluminum housing		Stainless steel housing	
	[kg]	[lb]	[kg]	[lb]
<b>Non-Ex / intrinsically-safe (Ex i / IS)</b>				
Compact	2.8	6.17	6.4	14.1
Remote converter ①	2.5	5.50	5.9	13.00
Probe housing ①	1.8	4.00	3.9	8.60
<b>Explosion proof (Ex d / XP)</b>				
Compact	3.2	7.05	7.5	16.50
Remote converter ①	2.9	6.40	7.1	15.65
Probe housing ①	1.8	4.00	3.9	8.60

① The remote version of the device has a "remote converter" and a "probe housing". For more data, refer to "Housing dimensions" at the start of this section.

## Probe weights

Probes	Min. process connection size		Weights	
	Thread	Flange	[kg/m]	[lb/ft]
Single cable Ø2 mm / 0.08"	G ½A; ½ NPTF	DN25 PN40; 1" 150 lb; 1½" 300 lb	0.016 ①	0.035 ①
Single cable Ø4 mm / 0.16"	G ¾A; ¾ NPT	DN25 PN40; 1" 150 lb; 1½" 300 lb	0.12 ①	0.08 ①
Double cable Ø4 mm / 0.16"	G 1½A; 1½ NPT	DN50 PN40; 2" 150 lb; 2" 300 lb	0.24 ①	0.16 ①
Single rod Ø8 mm / 0.31"	G ¾A; ¾ NPT	DN25 PN40; 1" 150 lb; 1½" 300 lb	0.41	0.28
Double rod Ø8 mm / 0.31"	G 1½A; 1½ NPT	DN50 PN40; 2" 150 lb; 2" 300 lb	0.82	0.56
Coaxial Ø22 mm / 0.9"	G ¾A; ¾ NPT	DN25 PN40; 1" 150 lb; 1½" 300 lb	0.79	0.53

① This value does not include the weight of the counterweight

## 3 INSTALLATION

### 3.1 Intended use

*Responsibility for the use of the measuring devices with regard to suitability, intended use and corrosion resistance of the used materials against the measured fluid lies solely with the operator.*

*The manufacturer is not liable for any damage resulting from improper use or use for other than the intended purpose.*

This TDR level transmitter measures distance, level, mass and volume of liquids, pastes, slurries, granulates and powders.

It can be installed on tanks, silos and open pits.

### 3.2 How to prepare the tank before you install the device

*To avoid measuring errors and device malfunction, obey these precautions.*

#### 3.2.1 General information for nozzles

*Follow these recommendations to make sure that the device measures correctly.*

*Do not put the process connection near to the product inlet. If the product that enters the tank touches the probe, the device will measure incorrectly.*

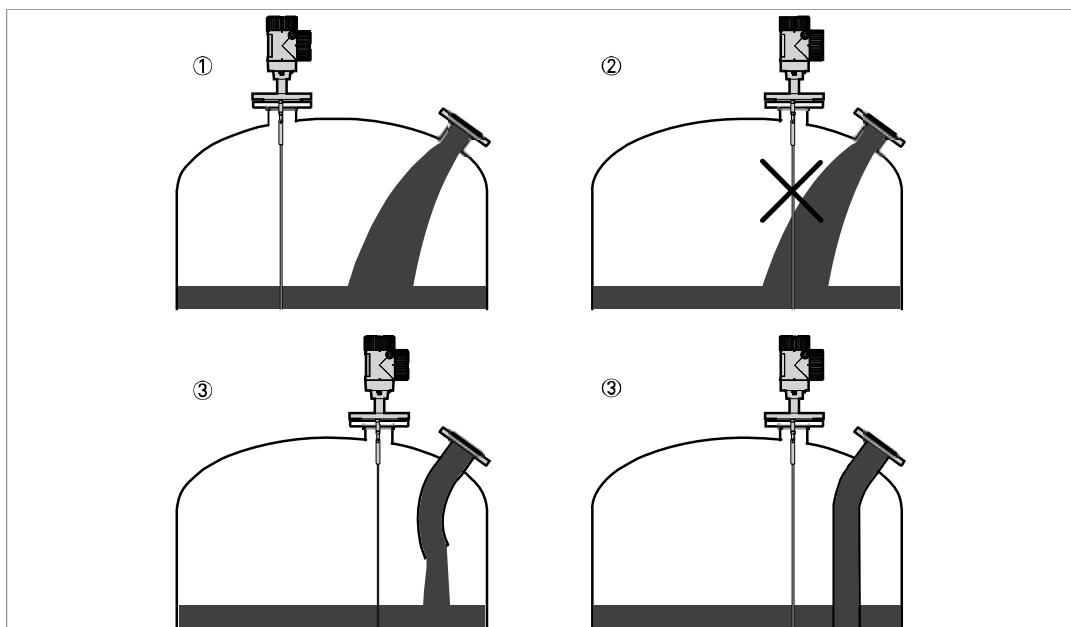

Figure 3-1: Do not put the device near to a product inlet

- ① The device is in the correct position.
- ② The device is too near to the product inlet.
- ③ If it is not possible to put the device in the recommended position, install a deflector pipe.

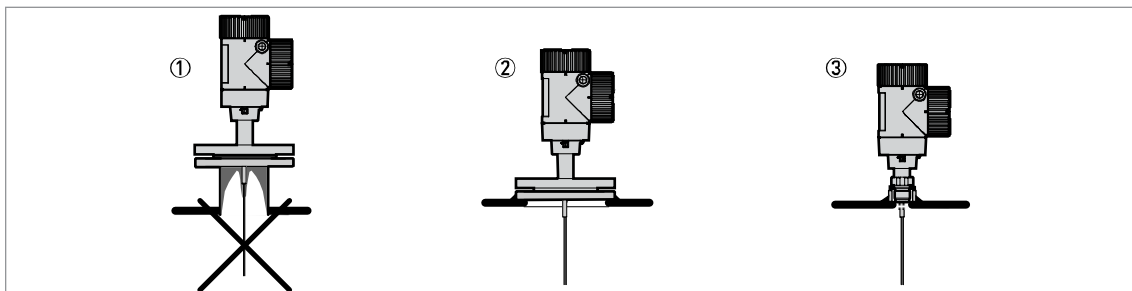

Figure 3-2: How to prevent build up of product around the process connection

- ① If product particles are likely to collect in holes, a nozzle is not recommended.
- ② Attach the flange directly to the tank.
- ③ Use a threaded connection to attach the device directly to the tank.

For single cable and single rod probes:

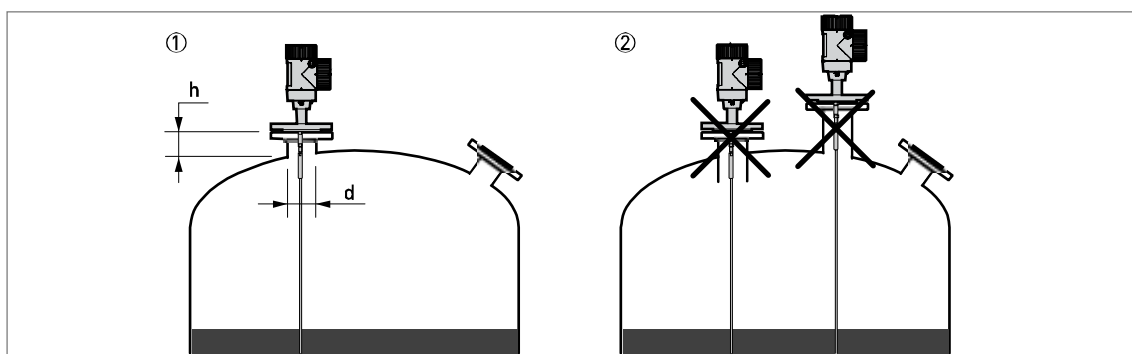

Figure 3-3: Recommended nozzle dimensions for single rod and single cable probes

- ① Recommended conditions:  $h \leq d$ , where  $h$  is the height of the tank nozzle and  $d$  is the diameter of the tank nozzle.
- ② The end of the nozzle must not have an extension into the tank. Do not install the device on a high nozzle.

*If the device is installed on a high nozzle, make sure that the probe does not touch the side of the nozzle (attach the probe end, ...).*



Figure 3-4: Sockets for threaded process connections

- ① Recommended installation
- ② The end of the socket must not have an extension into the tank

For double cable and double rod probes:

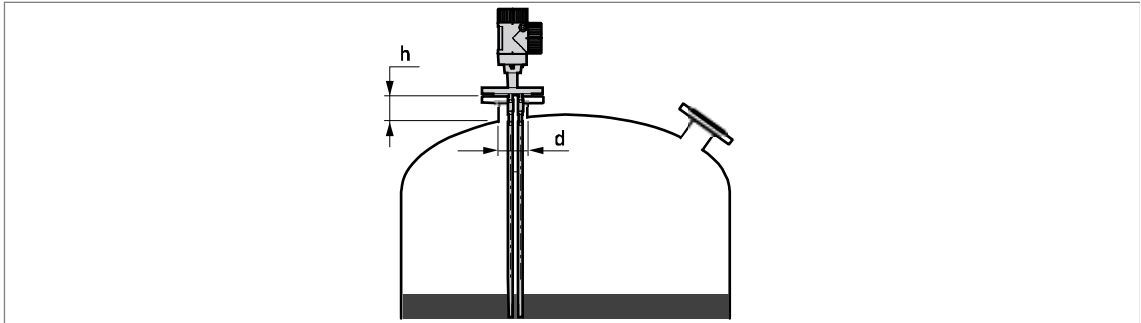

Figure 3-5: Recommended nozzle dimensions for double rod and double cable probes  
 $d \geq 50 \text{ mm} / 2''$ , where  $d$  is the diameter of the tank nozzle

For coaxial probes:

If your device has a coaxial probe, you can ignore these installation recommendations.

*Install coaxial probes in clean liquids that are not too viscous.*

### 3.2.2 Installation requirements for concrete roofs

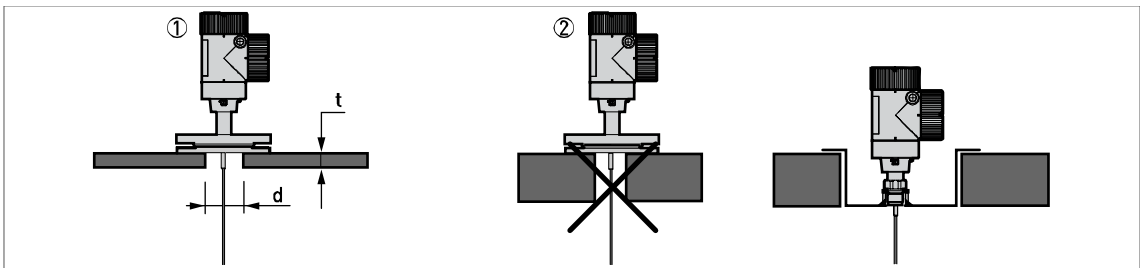

Figure 3-6: Installation on a concrete roof

- ① The diameter,  $d$ , of the hole must be greater than the thickness,  $t$ , of the concrete.
- ② If the thickness,  $t$ , of the concrete is greater than the diameter,  $d$ , of the hole, install the device in a recess.

### 3.3 Installation recommendations for liquids

#### 3.3.1 General requirements

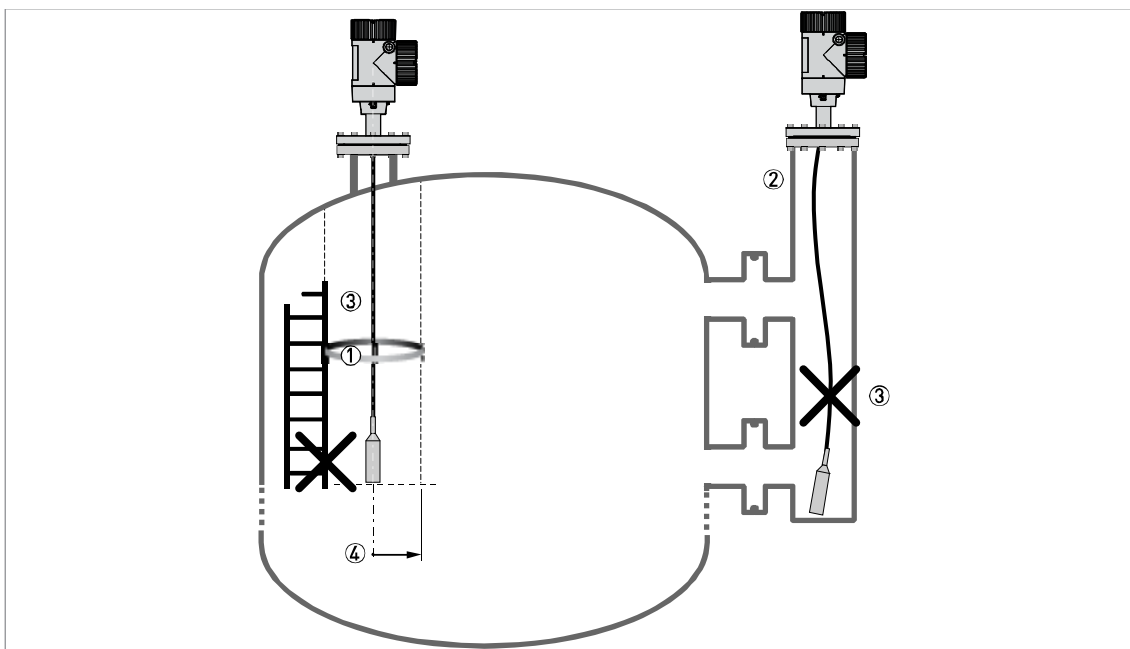

Figure 3-7: Installation recommendations for liquids

- ① The electromagnetic (EM) field generated by the device. It has a radius of  $R_{min}$ . Make sure that the EM field is clear of objects and product flow. Refer to the table that follows.
- ② If there are too many objects in the tank, install a bypass chamber or stilling well.
- ③ Keep the probe straight. If the probe is too long, shorten the probe length. Make sure that the device is configured with the new probe length. For more data on the procedure, refer to the handbook.
- ④ Empty space. Refer to the table that follows.

#### Clearance between the probe and other objects in the tank

Probe type	Empty space (radius, $R_{min}$ ), around the probe	
	[mm]	[inches]
Coaxial	0	0
Double rod / cable	100	4
Single rod / cable	300	12

### 3.3.2 Installation in standpipes (stilling wells and bypass chambers)

Use a standpipe if:

- The liquid is very turbulent or agitated.
- There are too many other objects in the tank.
- The device is measuring a liquid in a tank with a floating roof.

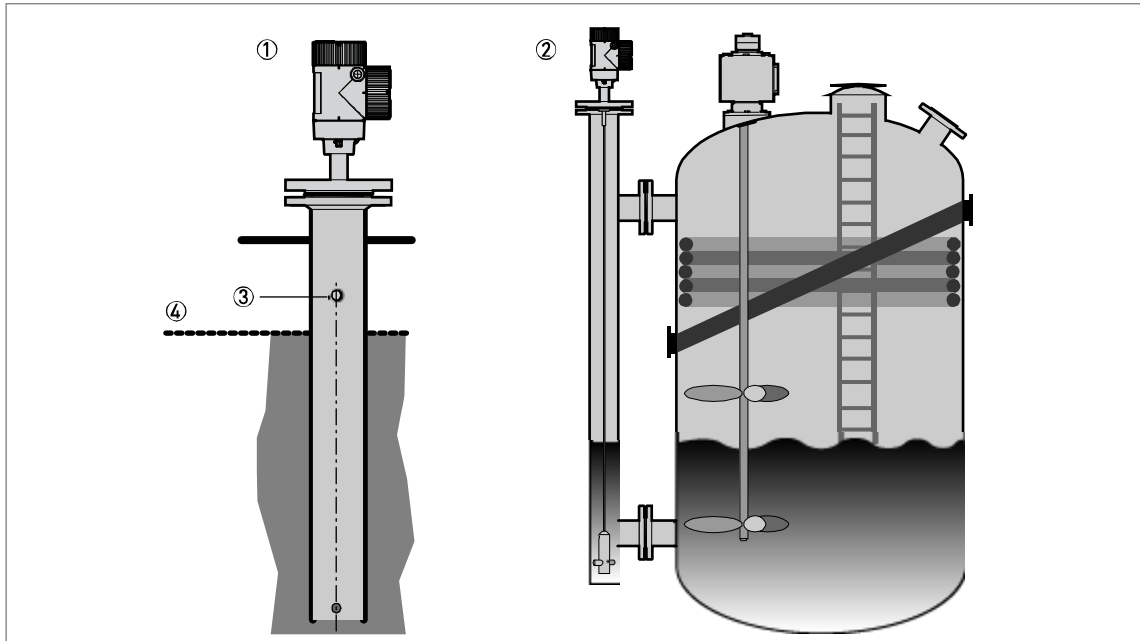

Figure 3-8: Installation recommendations for standpipes (stilling wells and bypass chambers)

- ① Stilling well
- ② Bypass chamber
- ③ Vent
- ④ Level of the liquid

*Stilling wells are not necessary for devices with coaxial probes. But if there is a sudden change in diameter in the stilling well, we recommend that you install a device with a coaxial probe.*

#### *Installation requirements*

- *The standpipe must be electrically conductive. If the standpipe is not made of metal, obey the instructions for empty space around the probe. For more data, refer to General requirements on page 31.*
- *The standpipe must be straight. There must be no changes in diameter from the device process connection to the bottom of the standpipe.*
- *The standpipe must be vertical.*
- *Recommended surface roughness:  $< \pm 0.1 \text{ mm} / 0.004''$ .*
- *The bottom of the stilling well must be open.*
- *Adjust the probe to the center of the standpipe.*
- *Make sure that there are no deposits at the bottom of the standpipe which can cause blockage of the process connections.*
- *Make sure that there is liquid in the standpipe.*



### Floating roofs

If the device is for a tank with a floating roof, install it in a stilling well.

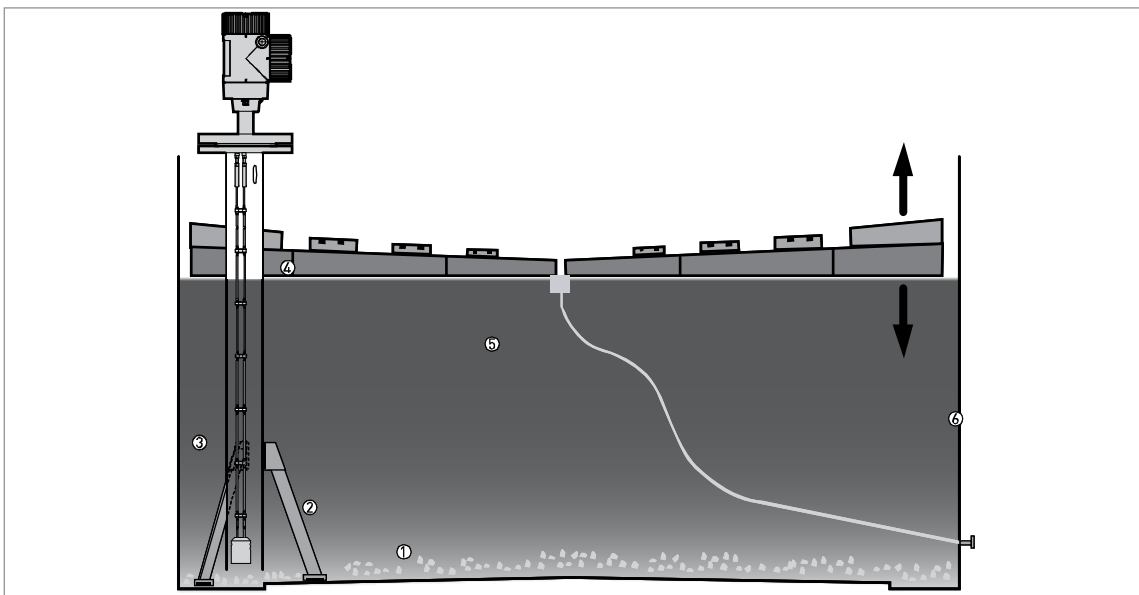

Figure 3-9: Floating roofs

- ① Sediment
- ② Support fixtures
- ③ Stilling well
- ④ Floating roof
- ⑤ Product
- ⑥ Tank

## 3.4 Installation recommendations for solids

### 3.4.1 Nozzles on conical silos

We recommend that you prepare the installation when the silo is empty.

**Risk of electrostatic discharge (ESD):** The device is resistant to electrostatic discharges of up to 30 kV, but it is the responsibility of the fitter and the user to prevent ESD.

Install the device at the correct location to measure level correctly and prevent too much bending and traction. If necessary, attach the probe to the bottom of the tank.

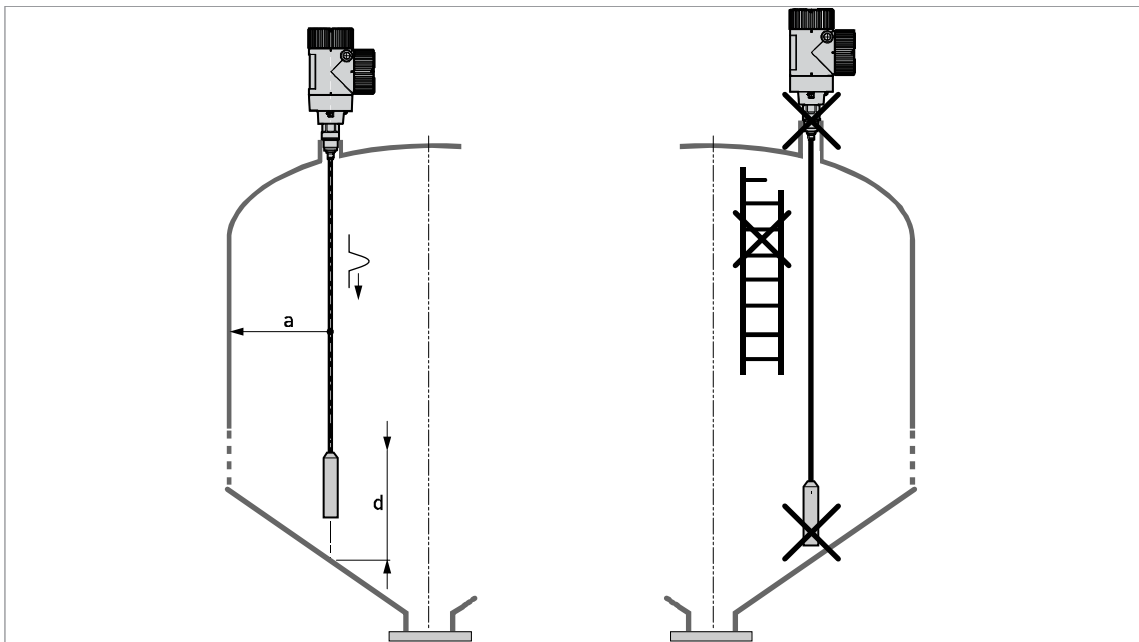

Figure 3-10: Installation recommendations for solids

$a \geq 300 \text{ mm} / 12''$

$d \geq 300 \text{ mm} / 12''$

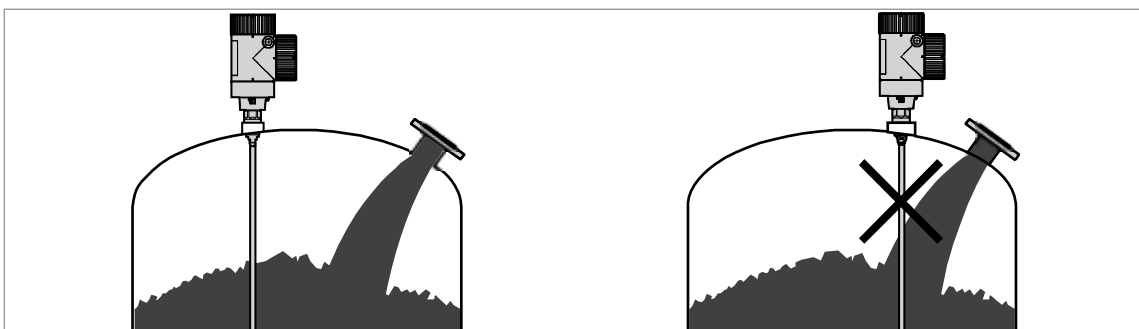

Figure 3-11: Do not install the probe near to a product inlet

## 4 ELECTRICAL CONNECTIONS

### 4.1 Electrical installation: 2-wire, loop-powered

#### 4.1.1 Compact version

##### Terminals for electrical installation

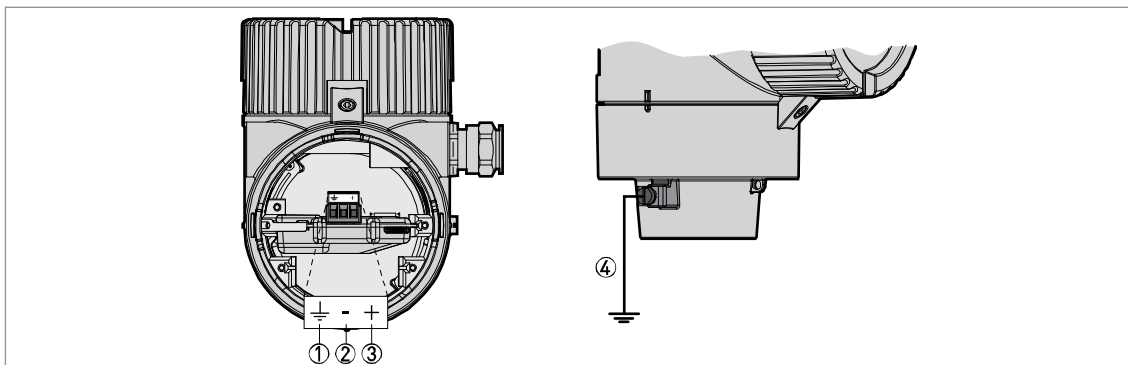

Figure 4-1: Terminals for electrical installation

- ① Grounding terminal in the housing (if the device is grounded)
- ② Current output –
- ③ Current output +
- ④ Location of the external grounding terminal (at the bottom of the converter)

The output energizes the device and is used for HART<sup>®</sup> communication.

#### 4.1.2 Remote version

##### Terminals for electrical installation

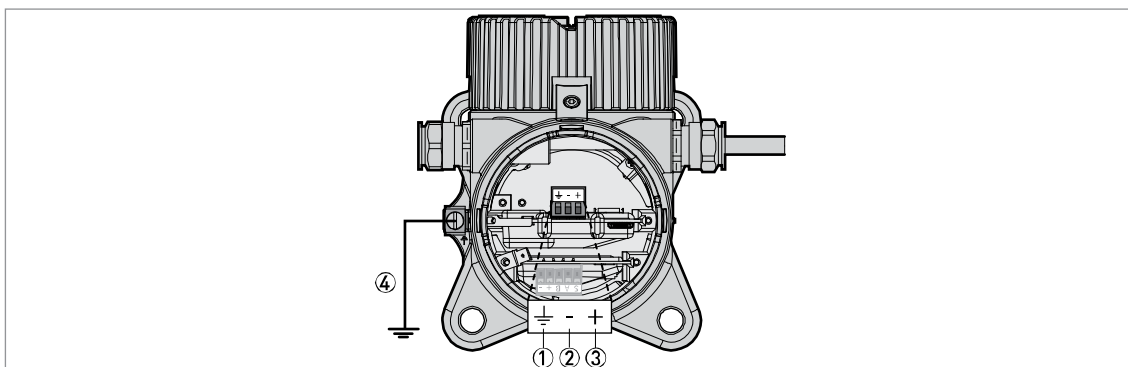

Figure 4-2: Terminals for electrical installation

- ① Grounding terminal in the housing (if the device is grounded)
- ② Current output –
- ③ Current output +
- ④ Location of the external grounding terminal (on the wall support)

Connections between the remote converter and the probe housing

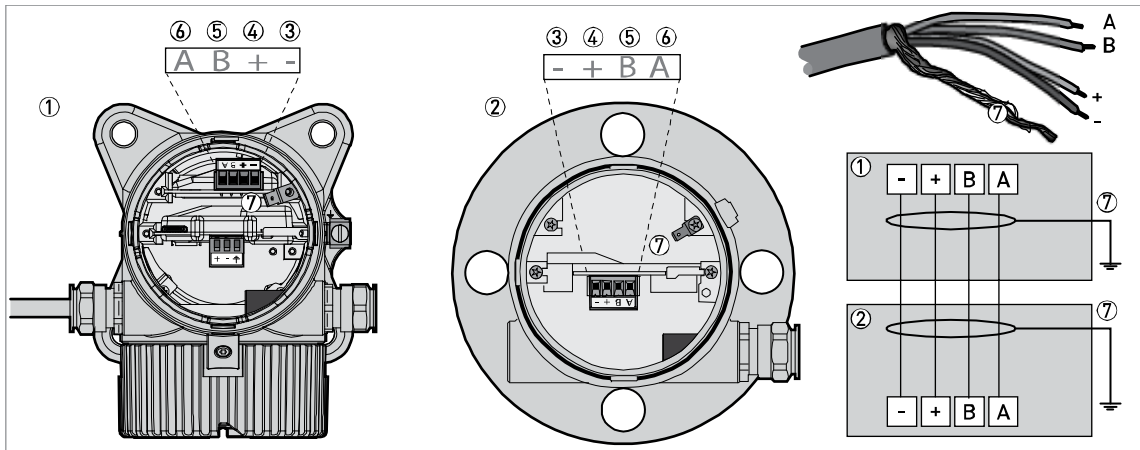

Figure 4-3: Connections between the remote converter and the probe housing

- ① Remote converter
- ② Probe housing
- ③ Power supply: voltage in -
- ④ Power supply: voltage in +
- ⑤ Signal cable B
- ⑥ Signal cable A
- ⑦ Shielding wire (attached to Faston connectors in the housings of the remote converter and the probe housing)

Refer to "Electrical installation: compact version" for more electrical installation data.

## 4.2 Non-Ex devices

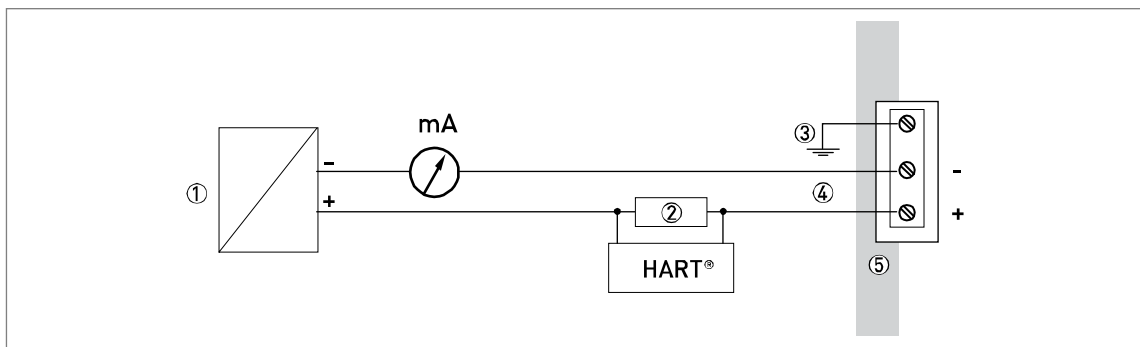

Figure 4-4: Electrical connections for non-Ex devices

- ① Power supply
- ② Resistor for HART® communication
- ③ Optional connection to the grounding terminal
- ④ Output: 12...30 VDC for an output of 22 mA at the terminal

## 4.3 Devices for hazardous locations

*For electrical data for device operation in hazardous locations, refer to the related certificates of compliance and supplementary instructions (ATEX, IECEx, cFMus, ...). You can download this documentation free of charge from our website.*

## 4.4 Networks

### 4.4.1 General information

The device uses the HART<sup>®</sup> communication protocol. This protocol agrees with the HART<sup>®</sup> Communication Foundation standard. The device can be connected point-to-point. It can also operate in a multi-drop network of up to 15 devices.

The device output is factory-set to communicate point-to-point. To change the communication mode from point-to-point to multi-drop, refer to "Network configuration" in the handbook.

### 4.4.2 Point-to-point networks

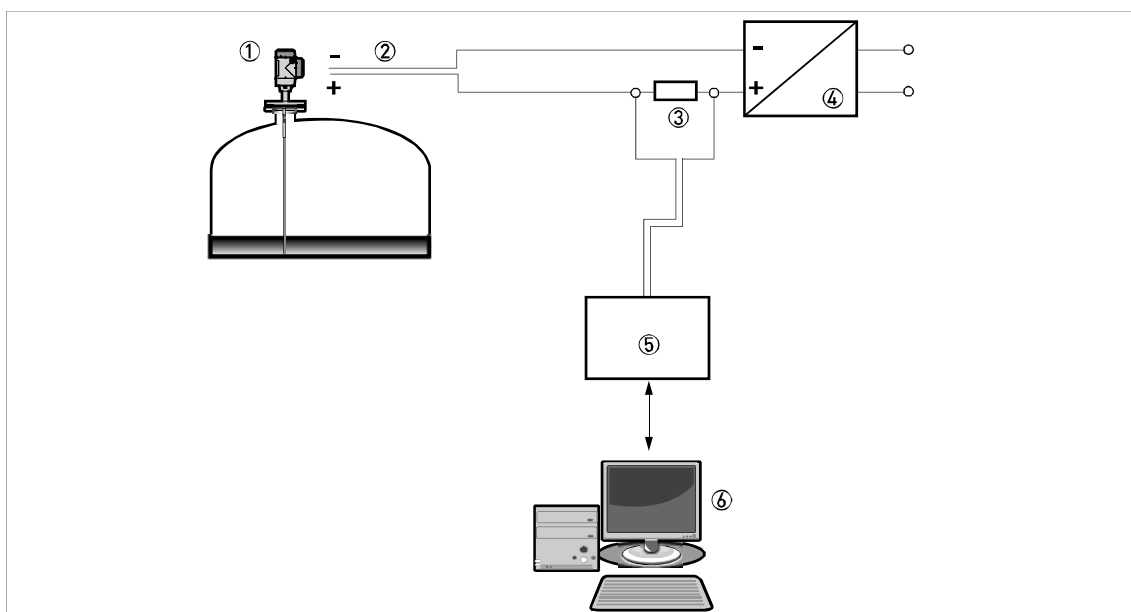

Figure 4-5: Point-to-point connection (non-Ex)

- ① Address of the device (0 for a point-to-point connection)
- ② 4...20 mA + HART<sup>®</sup>
- ③ Resistor for HART<sup>®</sup> communication
- ④ Power supply
- ⑤ HART<sup>®</sup> modem
- ⑥ HART<sup>®</sup> communication device

## 4.4.3 Multi-drop networks

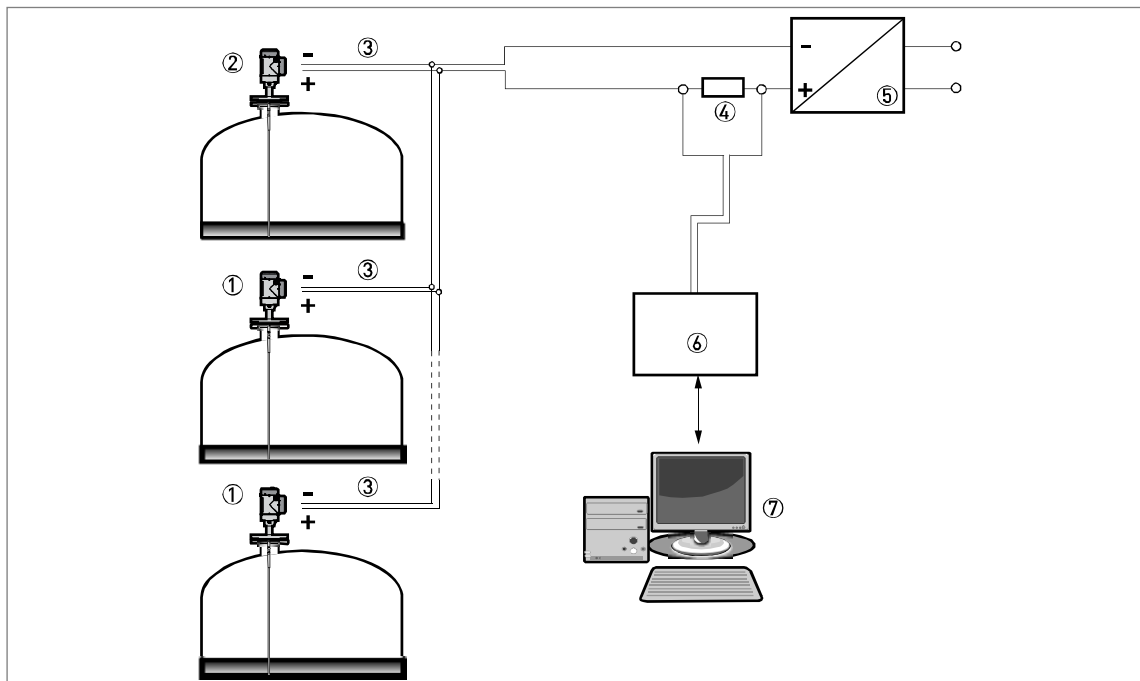

Figure 4-6: Multi-drop network (non-Ex)

- ① Address of the device (n+1 for multidrop networks)
- ② Address of the device (1 for multidrop networks)
- ③ 4 mA + HART<sup>®</sup>
- ④ Resistor for HART<sup>®</sup> communication
- ⑤ Power supply
- ⑥ HART<sup>®</sup> modem
- ⑦ HART<sup>®</sup> communication device

## 5 ORDER INFORMATION

### 5.1 Model code

080614

<b>LG01</b>	<b>4</b>	<b>Two-wire loop-powered Guided Wave Radar Level Meter :</b>
		<b>Version ( Housing material • Protection class )</b>
	1	Compact version (Aluminum • IP 66/67)
	2	Compact version (Stainless Steel • IP 66/67)
	3	Remote version (converter & probe housing : Aluminum • IP 66/67)
	4	Remote version (converter & probe housing : Stainless Steel • IP 66/67)
	5	Remote version (converter housing : Aluminum • probe housing : Stainless steel • IP 66/67)
		<b>Approval</b>
	0	Without
	1	ATEX Ex ia IIC T2...T6 + DIP ☉
	2	ATEX Ex d ia IIC T2..T6 + DIP ☉
	4	ATEX Ex ic IIC T2...T6 + DIP (Zone 2 & 22)
	6	IECEX Ex ia IIC T2...T6 + DIP ☉
	7	IECEX Ex d ia IIC T2...T6 + DIP ☉
	8	IECEX Ex d ic IIC T2...T6 + DIP (Zone 2 & 22)
	A	cFMus IS CL I/II/III, DIV 1, GPS A-G; CL I, Zone 0/20, Ex ia IIC/IIIC T2...T6
	B	cFMus XP-IS/DIP CL I/II/III, DIV 1, GPS A-G (A not for CAN); CL I, Zone 0/20, Ex d/tb IIC/IIIC T2...T6
	C	cFMus NI CL I/II/III, DIV 2, GPS A-G; CL I, Zone 2, Ex nA IIC T2...T6
	L	NEPSI Ex ia IIC T2 ~ T6 + DIP ☉
	M	NEPSI Ex d ia IIC T2 ~ T6 + DIP ☉
	R	INMETRO Ex ia IIC T2...T6 + DIP
	S	INMETRO Ex d ia IIC T2...T6 + DIP
	T	INMETRO Ex ic IIC T2...T6 + DIP (Zone 2 & 22)
		<b>Other approval</b>
	0	Without
	1	SIL 2 - only available for LevelWave LG01 (Compact Version) with 4...20 mA output
	4	CRN (Canadian Registration Number)
	5	CRN & SIL 2 - only available for LevelWave LG01 (Compact Version) w. 4..20 mA output
		<b>Process seal (Temperature • Pressure • Material) (Material to be checked by customer)</b>
	1	- 40°C ... +150°C (-40°F...+302°F) • -1 ... 40 barg (-14.5...580 psig) • FKM/FPM ☉ for all probes
	2	- 20°C ... +150°C (-4°F...+302°F) • -1 ... 40 barg (-14.5...580 psig) • Kalrez® 6375 for all probes
	3	- 50°C ... +150°C (-58°F...+302°F) • -1 ... 40 barg (-14.5...580 psig) • EPDM for all probes
	6	- 40°C ... +300°C (-40°F...+572°F) • -1 ... 40 barg (-14.5...580 psig) • FKM/FPM ☉ only for single cable Ø 2 mm (0.08") with high temperature (HT) extension
	7	- 20°C ... +300°C (-4°F...+572°F) • -1 ... 40 barg (-14.5...580 psig) • Kalrez® 6375 only for single cable Ø 2 mm (0.08") with high temperature (HT) extension
	8	- 50°C ... +250°C (-58°F...+482°F) • -1 ... 40 barg (-14.5...580 psig) • EPDM only for single cable Ø 2 mm (0.08") with high temperature (HT) extension
		<b>Probe (Type • Material • Measuring range) (other materials available on request)</b>
		<i>For liquids only:</i>
	2	Single rod - Ø8 mm (0.31") segmented • 316 L - 1.4404 • 1...6 m (1.97...19.69 ft)
	3	Single cable - Ø2 mm (0.08") • 316 - 1.4401 • 1...40 m (1.97...131.23 ft)
	6	Double rod - 2 x Ø8 mm (0.31") • 316 L - 1.4404 • 1...4 m (1.97...13.12 ft)
	7	Double cable - 2 x Ø4 mm (0.16") • 316 - 1.4401 • 1...40 m (1.97...131.23 ft)
	⇓	

## Model Code (continued)

					D	Single cable - Ø2 mm (0.08") • Hastelloy C22 • 1...40 m (1.97...131.23 ft)
					A	Coax - Ø22 mm (0.87") • 316 L - 1.4404 • 0.6 ... 6 m (0.98...19.69 ft)
					B	Coax - Ø22 mm (0.87") segmented • 316 L - 1.4404 • 0.6 ... 6 m (0.98...19.69 ft)
					E	Coax - Ø22 mm (0.87") • Hastelloy C22 • 0.6 ... 6 m (0.98...19.69 ft)
					P	Single Rod - Ø16 mm (0.64") • PVDF sheath • liquids: 1...4 m (3.28...13.12 ft) (Not cFMus) (Approval Class IIB only)
						<i>For liquids and solids:</i>
					1	Single rod - Ø8 mm (0.31") • 316 L - 1.4404 • 1...4 m (1.97...13.12 ft)
					4	Single cable - Ø4 mm (0.16") • 316 - 1.4401 • liquids : 1...40 m (1.97...131.23 ft) • solids : 1...20 m (1.97...65.62 ft)
						<i>For solids only:</i>
					5	Single Cable - Ø8 mm (0.32") • 316 • solids: 1...40 m (3.28...131.23 ft)
						<i>Probe connection without probe:</i>
					K	Probe connection in 316L / 1.4404 for single rod / single cable probe - probe not included - not valid for single cable Ø2 mm (0.08")
					L	Probe connection in 316L / 1.4404 for double rod / double cable probe - probe not included
						<b>Probe end (Type • Material • suited for Probe type) (only for single &amp; double cable)</b>
					0	Without ( <i>for rod and coax probes</i> )
					1	Counterweight Ø14 x 100 mm (0.55 x 3.94") • 316 L - 1.4404 • Single cable - Ø2 mm (0.08")
					F	Counterweight Ø14 x 100 mm (0.55 x 3.94") • Hastelloy C 22 • Single cable - Ø2 mm (0.08")
					2	Counterweight Ø20 x 100 mm (0.79 x 3.94") • 316 L - 1.4404 • Single cable - Ø4 mm (0.16")
					3	Counterweight Ø12 x 100 mm (0.47 x 3.94") • 316L • for Single Cable - Ø8 mm (0.32")
					4	Counterweight Ø38 x 245 mm (1.05 x 9.65") • 316L • for Single Cable - Ø8 mm (0.32")
					5	Counterweight Ø38 x 60 mm (1.5 x 2.36") • 316 L - 1.4404 • Double cable - Ø4 mm (0.16")
					8	Chuck • 316 L - 1.4404 • Single cable - Ø4 mm (0.16")
					B	Crimped end • 316 L - 1.4404 • Single cable - Ø4 mm (0.16")
					D	Open end • 316 L - 1.4404 • Single cable - Ø4 mm (0.16")
					7	Turnbuckle • 316 L - 1.4404 • Single/double cable - Ø4 mm (0.16")
					A	Threaded end • 316 L - 1.4404 • Single/double cable - Ø4 mm (0.16")
						<b>Process connection: Size / Pressure class / Flange finish</b> (Standard material is Stainless Steel; Hastelloy C on request)
					C	½in Thread ①
					D	¾in Thread ②
					E	1in Thread ②
					G	1½in Thread
					E	DN25 EN 1092-1 ②
					G	DN40 EN 1092-1 ②
					H	DN50 EN 1092-1
					L	DN80 EN 1092-1
					M	DN100 EN 1092-1
					P	DN150 EN 1092-1
					R	DN200 EN 1092-1
					E	1in ASME B16.5 ②
					G	1½in ASME B16.5 ②
					H	2in ASME B16.5
					L	3in ASME B16.5
					↓	



Model Code (continued)

									(continued)
								M	4in ASME B16.5
								P	6in ASME B16.5
								R	8in ASME B16.5
								G	40A JIS B2220
								H	50A JIS B2220
								L	80A JIS B2220
								M	100A JIS B2220
								P	150A JIS B2220
								R	200A JIS B2220
									<b>Process connection: Size / Pressure class / Flange face finish</b>
								0	Without
								P	G-Thread
								A	NPT-Thread B1.20.1
								B	NPTF-Thread B1.20.3 (Dryseal)
								D	PN 10
								E	PN 16
								F	PN 25
								G	PN 40
								1	150 lbs
								2	300 lbs; with 6in, 8in: ④
								U	JIS 10K
									<b>Process connection: Size / Pressure class / Flange face finish</b>
								0	Without ( <i>threaded</i> )
								1	Form B1 (for EN 1092-1)
								A	RF (for ASME B16.5) ③
								P	RF (for JIS B2220)
								2	Form B2 (for EN 1092-1) ②
								3	Form C (for EN 1092-1)
								4	Form D (for EN 1092-1)
								5	Form E (for EN 1092-1)
								6	Form F (for EN 1092-1)
								B	FF (Flat Face) (for Asme B16.5)
								M	RJ (Ring Joint)
								C	LG (Large Groove)
								D	LF (Large Female)
								E	LT (Large Tongue)
								F	LM (Large Male)
								G	SG (Small Groove)
								H	SF (Small Female)
								K	ST (Small Tongue)
								L	SM (Small Male)





Invensys is now a part of Schneider Electric. ArchestrA, Avantis, DolpHin, Esscor, Eurotherm, Foxboro Eckardt, Foxboro, I/A Series, Foxboro Evo, IMServ, InFusion, SimSci, Skelta, Triconex, and Wonderware are trademarks of Invensys Ltd, its subsidiaries or affiliates. All other brands and product names may be the trademarks or service marks of their representative owners.

© 2014 Invensys Limited. All rights are strictly reserved.

No part of the material protected by this copyright may be reproduced or utilized in any form or by any means, electronic or mechanical, including photocopying, recording, broadcasting, or by any information storage and retrieval system, other than for the purpose to act as an aid in operating the equipment to which the document relates without permission in writing from Invensys. Invensys pursues a policy of continuous development and product improvement. The specifications, and terms within this document may therefore be changed without notice. The information in this document is given in good faith, but is intended for guidance only. Invensys will accept no responsibility for any losses arising from errors in this document.

FOXBORO ECKARDT GmbH  
Pragstr. 82  
D-70376 Stuttgart  
Germany  
Tel. +49 (0)711 502-0  
Fax +49 (0)711 502-597  
<http://www.foxboro-eckardt.com>

ECKARDT S.A.S.  
20 rue de la Marne  
F-68360 Soultz  
France  
Tel. + 33 (0)3 89 62 15 30  
Fax + 33 (0)3 89 62 14 85

DOKT 558 616 012

