

IP26 Series Current to Pneumatic Converter



The IP26 (current to pressure) transducer converts a 4–20mA electrical current signal to a proportional linear pneumatic output. The unique conversion technology provides a high level of accuracy and repeatability for the operation of actuated valves. A low mass control circuit provides consistent output in high vibration applications. This compact unit is housed in an explosion proof enclosure that is designed for pipe, bracket or direct manifold mounting. This explosion-proof and intrinsically safe field device is available with a built-in volume booster.

FEATURES

- 4 to 20 mA, 2-wire Loop powered
- Compact design, small size and low weight
- Approvals Intrinsically Safe and Explosion Proof ATEX, FM and CSA certification
- Gas and Dust certification
- Position insensitive – Unit can be mounted in any plane and is stable in high vibration environments
- Low power consumption minimize loop load

SPECIFICATIONS

Functional Specifications

Input	4-20 mA
Outputs (to be selected in Model Code)	0.2 -1 bar (3 - 15 psig) 0.1 -1.7 bar (1.5 - 25 psig) 0.4 -2 bar (6 - 30 psig) Outputs with pressure up to 6 bar (90 psi) can be obtained by adding a volume booster with amplifying ratio – Please consult us !
Air Consumption	2.83 l/min (0.1 scfm)
Supply Pressure Note: Supply pressure must be a minimum of 0.3 bar (5 psig) above maximum output	0.2 -1 bar: 1.5 bar (22 psig) max 0.1 - 1.7 bar: 2.8 bar (42 psig) max 0.4 - 2 bar: 2.8 bar (42 psig) max
Flow Capacity	4.1 m ³ /h (2.4 scfm) max.
Temperature Limits	-40 °C to 85 °C (-40 °F to 185 °F) / down to -55 °C (-67 °F) with option -T
Relative Humidity	75% average - 95% short time non-condensing
Impedance	260 Ohms @ 21 °C (70 °F)
Loop Load	5.2 Volts @ 21 °C (70 °F)

Performance Specifications

Linearity (Independent)	< ±0.5% of span
Hysteresis	< ±0.3% of span
Deadband	< ±0.1% of span
Repeatability	< ±0.3% of span; < ±0.15% of span typical
Mounting Orientation	< ±0.5% / 90 degree change
Air Supply Sensitivity	< 0.3% / 1.5 psig (0.10 bar) change
Vibration Effect	< ±1% up to 10 g and 20-80 Hz
Temperature Effect	< ±0.75% / 12 °C (/ 10 °F) change

Physical Specifications

Housing	IP 65 (NEMA 4X)
Port Sizes	In/Out Pneumatic: 1/4" NPT; gauge part: 1/8" NPT Electric: M20x1.5 (ATEX) / 1/2 NPT (FM / CSA)
Media	Clean, dry, oil-free, instrument air, filtered to 40 micron
Electrical Connections	Terminal block
Mounting	2" pipe (optional)
Materials	Housing: Chromate-treated Aluminum with epoxy paint. IP65 (NEMA 4X) Elastomers: Buna-N Trim: Stainless steel; brass; zinc-plated steel Label: Stainless steel
Weight	0.64 kg (1.4 lb)

HAZARDOUS AREA CLASSIFICATION

Cover label: ATEX

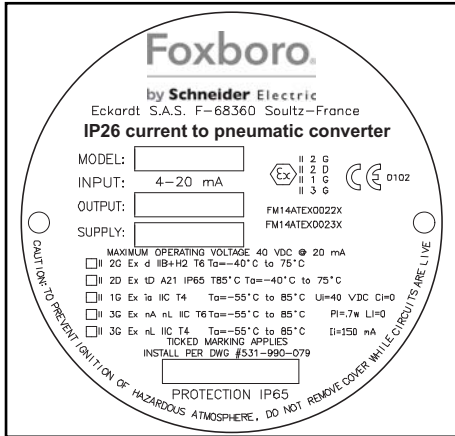

Cover label: FM / CSA

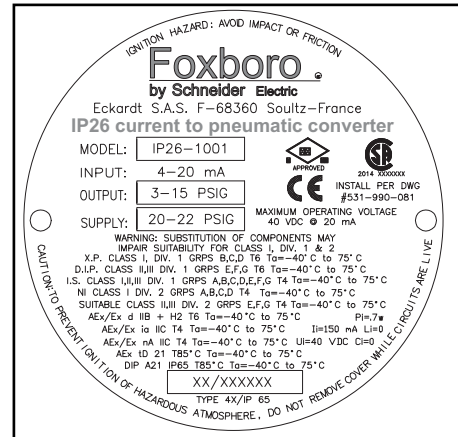

ATEX Approvals

	Entity Parameters	Temperature Code	Enclosure	Certificate
Intrinsic Safety II 1 G Ex ia IIC	V _{max} = 40 Vdc I _{max} = 150 mA P _i = 0.7 W C _i = 0 nF L _i = 0 mH	T* -55°C to T _a max*	IP65	FM14ATEX0022 X
Flameproof II 2 G Ex d IIB + H2 II 2 D Ex tD A21 T85°C	— — —	T6 -40°C ≤ T _a ≤ +75°C	IP65	FM14ATEX0022 X
Limited Energy/Non-Sparking II 3 G Ex nL IIC II 3 G Ex nA nL IIC	— — —	T* -55°C to T _a max* T6 -55°C T _a +85°C	IP65	FM14ATEX0023 X

*See energy limiting parameters. Refer to Master Instruction MI EVE0403.

Entity Parameters:

U_i (V_{max}) = 40 VDC C_i = 0 μF
I_i (I_{max}) = 150 mA L_i = 0 mH
P_i = 0.7 W max.

IP26-1a00 and I/P Converter for SRI983:

II 3 G Ex nL IIC T* T_a = -55°C to +85°C

A = Output Pressure Range: 0, 1, or 2

Energy Limitation Parameters

* Temperature Class	T _a	I _i	U _i	P _i
T4	85 °C	60 mA	38.8 V	2.328 W
T4	85 °C	100 mA	30 V	3.0 W
T4	80 °C	120 mA	28 V	3.36 W
T4	70 °C	150 mA	25.5 V	3.825 W
T5	70 °C	60 mA	38.8 V	2.328 W
T5	55 °C	100 mA	30 V	3.0 W
T5	45 °C	120 mA	28 V	3.36 W
T5	85 °C	23 mA	6.75 V	0.155 W
T6	60 °C	50 mA	42.5 V	2.125 W
T6	55 °C	60 mA	38.8 V	2.328 W

FM Approvals (FM) & Canadian Standards Association (CSA) Approvals**Intrinsically Safe:**

Class I, Div. 1, Groups A, B, C & D
Class II, Div. 1, Groups E, F & G
Class III, Div. 1, Fibers
Enclosure Nema 4X (IP65)
Rated 4-20 mA, 40 VDC Max.
Temp. Code T4 Ta = + 70°C

Explosion Proof:

Class I, Div. 1, Groups A, B, C, D
Enclosure Nema 4X (IP65)
Temp. Code T6

Dust Ignition Proof:

Class II & III, Div. 1, Groups E, F & G
Enclosure Nema 4X (IP65)
Temp. Code T6

Non-Incendive:

Class I, Div. 2, Groups A, B, C & D
Class II, Div. 2, Groups E, F & G
Class III, Div. 2, Fibers
Enclosure Nema 4X (IP65)
Temp. Code T6

Entity Parameters:

$V_{max} = 40 \text{ VDC}$ $C_i = 0 \text{ } \mu\text{F}$
 $I_{max} = 150 \text{ mA}$ $L_i = 0 \text{ mH}$

Entity Installation Requirements:

$V_{max} \geq V_t \text{ OR } V_{oc}$
 $I_{max} \geq I_t \text{ OR } I_{sc}$
 $C_a \geq C_i + C_{cable}$
 $L_a \geq L_i + L_{cable}$

Note: Cable capacitance and inductance must be considered when connecting to pressure transducer.

INSTALLATION DRAWING NO. 531-990-081

1. (North America) Control equipment connected to the Associated Apparatus must not use or generate more than 250 Vrms or Vdc.
2. (North America) The IS Barriers or Equipment (Associated Apparatus) must be FM Approved and CSA certified and the configuration of associated Apparatus must be FM Approved and CSA certified under the Entity Concept. The Associated Apparatus may be installed within the Hazardous (Classified) location for which it is certified. The Associated Apparatus and hazardous location loop apparatus manufacturer's control drawings must be followed when installing this equipment. An AEx [ib] Associated Apparatus is suitable only for connection to Class I, Zone 1, Hazardous (Classified) Locations and is not suitable for Class I, Zone 0, or Class I, Division 1 Hazardous (Classified) Locations.
(ATEX) The IS Barriers or other Associated Apparatus shall comply with the ATEX directive 94/9/EC.
3. (US) Installation should be in accordance with ANSI/ISA RP12.06.01 "Installation of Intrinsically Safe Systems for Hazardous (Classified) Locations" and Article 500 of the National Electrical Code (ANSI/NFPA 70)
(Canada) Installation should be in accordance with Section 18 of the Canadian Electrical Code.
(ATEX) Installation shall be in accordance with the applicable local installation rules Energy Limitation Parameters specified.
4. (North America) All units suitable for Type 4X installations.
5. (North America) Units are suitable for Class I, Division 2, Groups A, B, C, and D hazardous (classified) locations. Transducers to be installed in accordance with the (US) National Electrical Code (ANSI/NFPA 70) Division 2 hazardous (classified) location wiring techniques
(Canada) Canadian Electrical Code.
6. The Intrinsic Safety Entity concept allows the interconnection of two Intrinsically safe devices with entity parameters not specifically examined in combination as a system when:

Entity Parameters for: IP26 $U_i (V_{max}) = 40 \text{ V}$ $I_i (I_{max}) = 150 \text{ mA}$ $C_i = 0$ $L_i = 0$ $P_i = 0.7 \text{ Watt}$	$U_i \text{ or } V_{max} > U_o \text{ or } V_{oc}$ $I_i \text{ or } I_{max} > I_o \text{ or } I_{sc} \text{ or } I_t$ $C_a \text{ or } C_o > C_i + C_{cable}$ $L_a \text{ or } L_o > L_i \div L_{cable}$ $P_i > P_o.$
---	---
7. No revision to this drawing is permitted without prior FM Approval and CSA Certification.

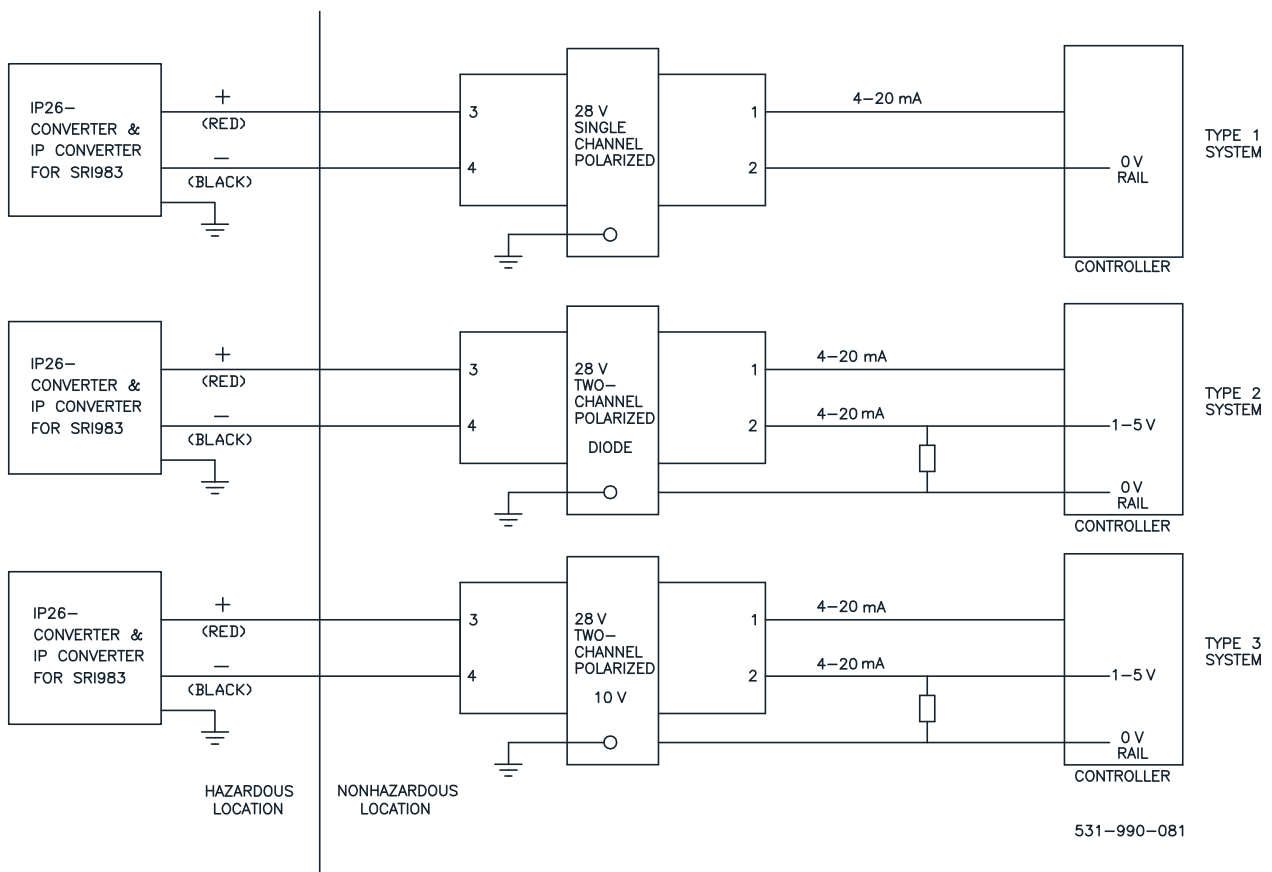

MODEL CODES IP26

Electro/pneumatic Signal Converter	IP26 -				
Input Signal					
4 - 20 mA		1			
Output Signal (without Output gauge)					
0.2 - 1 bar (3-15 psi)			0		
0.1 - 1.7 bar (1.5-25 psi)			1		
0.4 - 2 bar (6-30 psi)			2		
Body Material					
Aluminium				0	
Stainless Steel (not released)				1	
Electrical Certification					
ATEX Intrinsically Safe and Explosion Proof					0
FM & CSA, IS and XP					1
Option					
Low temperature down to -55°C (-67 °F)					-T

MODEL CODES ACCESSORIES FOR IP26

2 inch pipe mounting kit (steel zinc plate and clear chromate)	EBZG-IP1
Gauge for Output pressure (scale 0 - 2.5 bar) (stainless steel housing)	EBZG-IP2
Pipe for gauge mounting (stainless steel)	VG-92
Filter regulator FRS02 (Aluminium Housing)	FRS02
Pipe VG-91 (stainless steel)	VG-91
Cable Entry 1/2" NPT via adaptor (Brass Nickel coated)	AD-A5
Cable Entry 1/2" NPT via adaptor (Stainless steel)	AD-A6

EC Declaration of Conformity

We, FOXBORO ECKARDT GmbH
 Pragstr. 82
 D-70376 Stuttgart

declare that the IP26 Transducer family to which this declaration applies, comply with these standards:

EN 50082-1:1998

EN 55011:1999

EN 61010-1:1993 including AMD2:1995

Following the provisions of EMC directive 89/336/EEC

EN 60079-0:2006

EN 60079-11:2007

EN 60079-26:2007

EN 60079-1:2007

EN 61241-0:2007

EN 61241-1+Corr.1:2004/2005

EN 60529+A1, A2:1992/2000

EN 60079-15:2005

Following the provisions of EMC directive 94/9/EC

DIMENSIONS

I/P Converter for use with pneumatic positioner SRP981 / SRI983

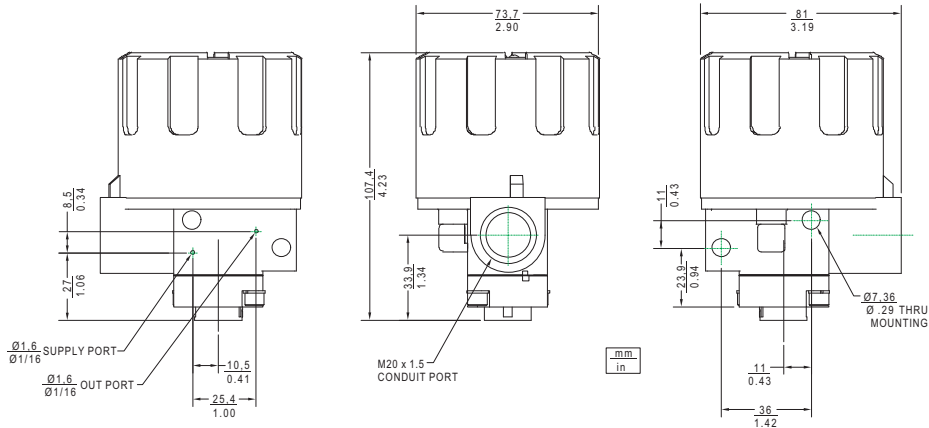

IP26 Series Stand Alone I/P converter

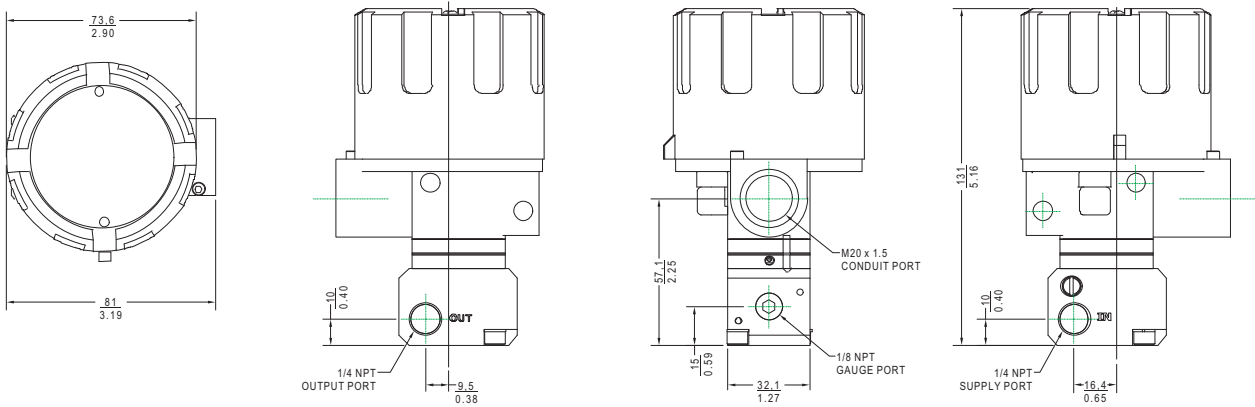

Optional 50 mm / 2" Bracket, EBZG-IP1

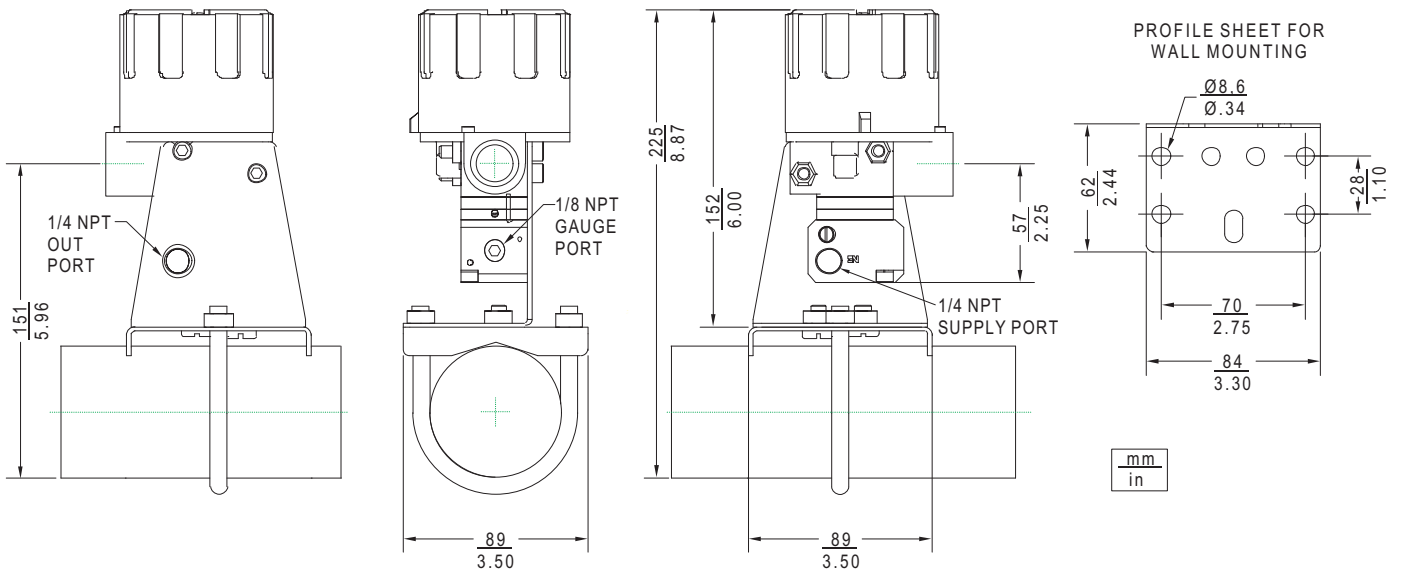

EXAMPLES FOR MOUNTING

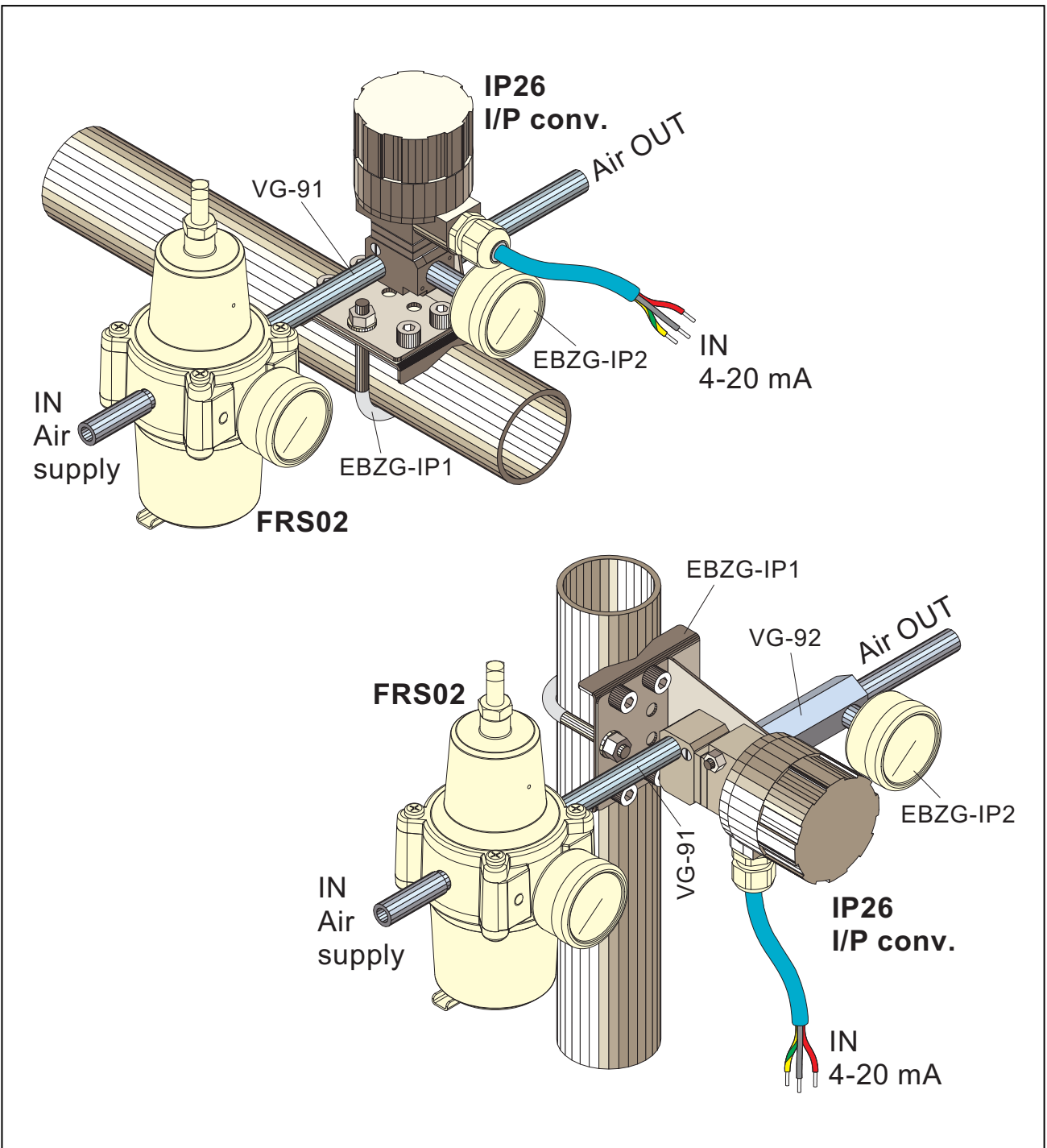

Invensys Systems, Inc.
 38 Neponset Avenue
 Foxboro, MA 02035
 United States of America

schneider-electric.com

Global Customer Support
 Toll free: 1-866-746-6477
 Global: 1-508-549-2424
 Website:
<http://support.ips.invensys.com>

Copyright 2010-2016 Invensys Systems, Inc.
 All rights reserved.
 Invensys, Foxboro, and I/A Series are trademarks of Invensys Limited, its subsidiaries, and affiliates. All other trademarks are the property of their respective owners.

DOKT 558 694 028
 FD-PSS-PO-06-EN