

244LVP – Intelligent Buoyancy Transmitter for Liquid Level, Interface and Density

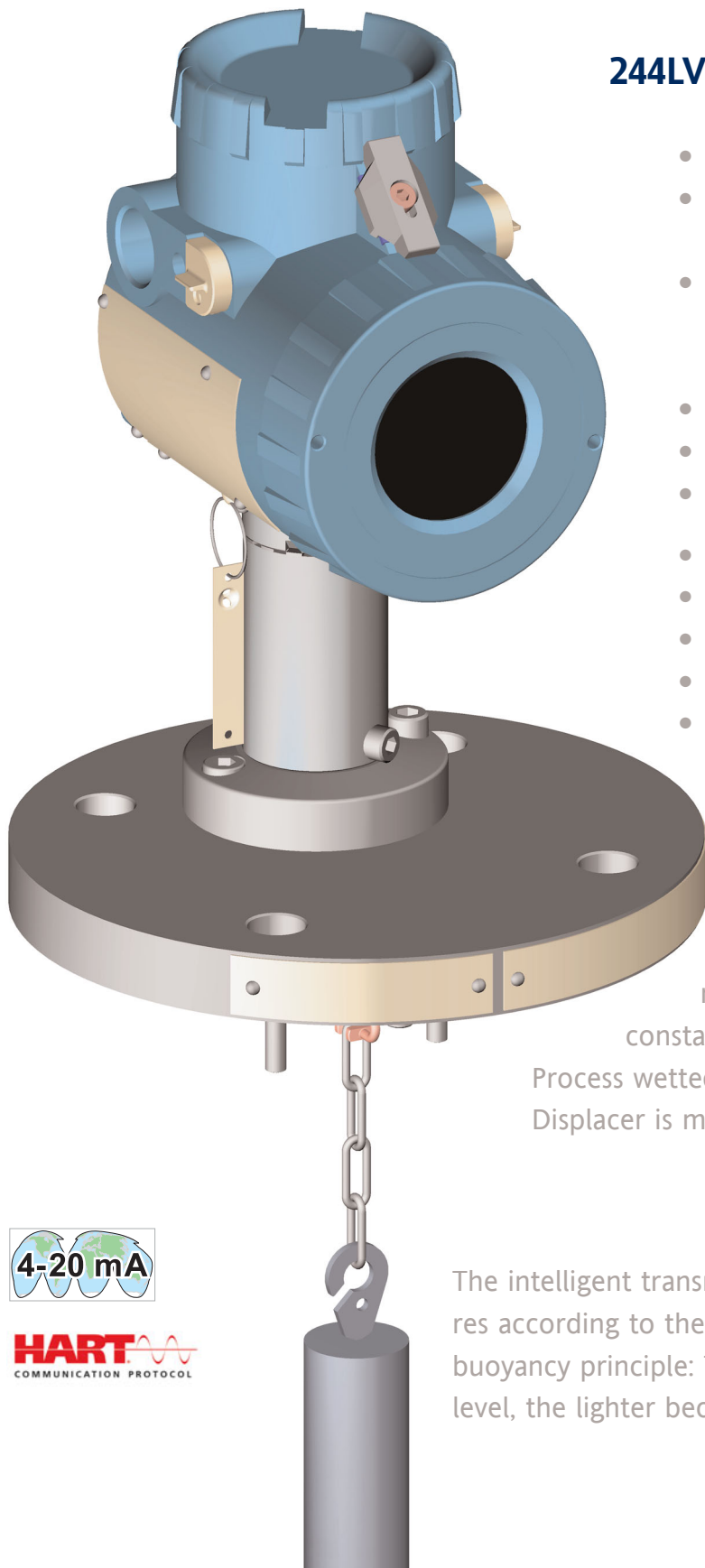

244LVP - The Economic Alternative.

- For measurements of liquids, at vessels:
- Liquid level:
 - Measuring range 0 ... 50 mm to 0 ... 3 m
- At given level:
 - Measuring of density
 - Position of interface of two liquids
- At process temperatures of $-50 \dots +120 \text{ }^{\circ}\text{C}$
- At process pressures of vacuum ... 40 bar
- At humidity up to 100 %, IP66
- 2-wire transmitters, with 4-20 mA or HART
- Nominal widths DN 50 and DN 80 (2 in, 3 in)
- Operating push buttons at instrument
- Upper part with LCD turnable to the operator
- ATEX Certification

The 244LVP is suitable for all industry applications, due to a robust modular design, where reliability is equally important as durability and constant high accuracy.

Process wetted parts consist of stainless steel 1.4404 or 1.4571. Displacer is made of SS, PTFE, PTFE+Carbon or Hastelloy C.



The intelligent transmitter 244LVP measures according to the proven Archimedes buoyancy principle: The higher the liquid level, the lighter becomes the displacer.

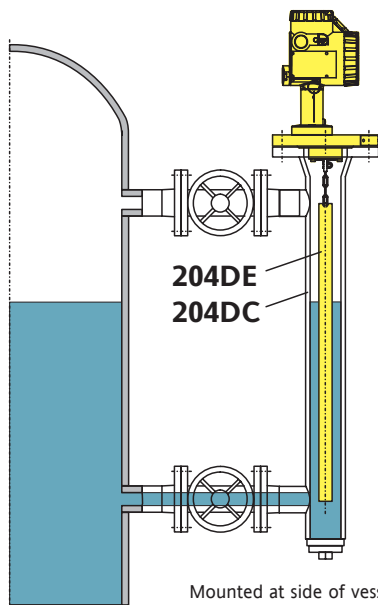

Mounted at side of vessel, displacer 204DE, with displacer chamber 204DC

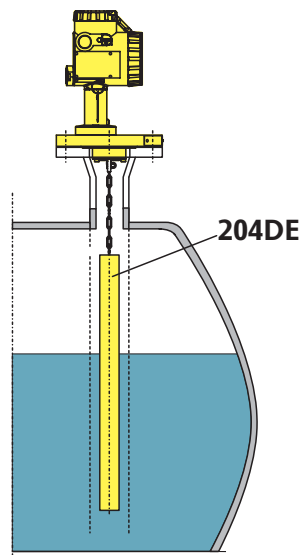

Mounted on top of vessel

Additional technical Data

In Process

- Accuracy $\pm 0.2\%$
- Sensor with no moving parts
- Reliable interface measurement – also at diffuse interface
- Explosion proof and intrinsically safe

Electronic

- Output signal linear or customized
- Supply Voltage 12 ... 42 V DC

Operation

- At instrument with push buttons
- Digital with Hand Held Terminal HT991 or PC20/PC50 calibration and configuration software
- LCD indicator for measuring values, operating status and configuration

Influence from Process

Temperature	▶ very little influence
Pressure	▶ very little influence
Steam, Fog	▶ no influence
Dielectric constant	▶ no influence
Foam	▶ no influence
Vibrations	▶ minimised due to Smart Smoothing and Damping
Motion of fluid	▶ very little influence (if necessary use protecting tube or displacer chamber)
Diffuse interface	▶ no influence
Displacer stroke	▶ Zero (no position alteration at liquid level change)
Corrosive fluids	▶ no influence (instruments are delivered in resistant materials)
Vessel material	▶ no influence
Deposits on vessel	▶ no influence
Deposits on displacer	▶ very little influence

FOXBORO ECKARDT GmbH
 Pragstrasse 82
 D-70376 Stuttgart · Germany
 Telefon +49 (0)711 502-0
 Telefax +49 (0)711 502-597
<http://www.foxboro-eckardt.com>
 e-mail salesupport@foxboro-eckardt.de